



**BUSH
HOG**

**PRODUCT
GUIDE**



BUSH HOG® PRODUCT LINE



Finishing Mowers



Crop Flail Shredders



Landscape Implements



Single-Spindle Rotary Cutters



Boom Mowers

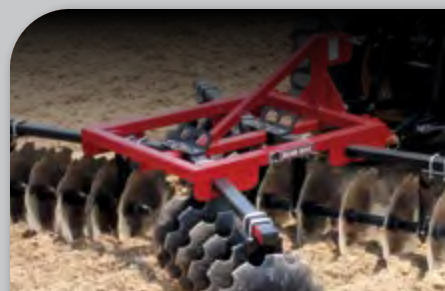

Tillage Implements



Multi-Spindle Rotary Cutters



Skid Steer Brush Cutters



Hay Tools



Flex-Wing Rotary Cutters



Construction Implements



Snow Removal Equipment



IF IT DOESN'T SAY
BUSH HOG®
IT JUST WON'T CUT IT™

10 REASONS WHY TO BUY BUSH HOG®

01



Proven, trusted,
and reputable
brand since 1951

06



10 year rotary
cutter gearbox
limited warranty

02



Broad range of
durable products
to meet your
needs

07



Extensive North
American dealer
network to
support you

03



Superior
customer service
and technical
support before
and after the sale

08



Consistently
setting the
industry standard
for generations

04



Excellent parts
availability -
95% same-day
fill rate

09



Create a custom
look with
multiple color
options to match
your tractor

05



Competitive
retail financing
packages

10



Rugged products
built to last



SCAN THE QR CODE WITH YOUR MOBILE DEVICE TO VIEW
THE LATEST DIGITAL VERSION OF OUR PRODUCT GUIDE

FINISHING MOWERS

HDTH Series Rear Discharge Mowers	FM1	6
TDC Series Tri-Deck Mowers	FM2	7
Finishing Mower Spec Comparison Chart	FM3	8

SINGLE-SPINDLE ROTARY CUTTERS

BH110 Series Single-Spindles	SS1	10
BH210-2 Series Single Spindles	SS2	11
BH310-2 Series Single-Spindles	SS3	12
BH410 Series Single Spindles	SS4	13
BH510 Series Single-Spindles	SS5	14
Single-Spindle Spec Comparison Chart	SS6	15

MULTI-SPINDLE ROTARY CUTTERS

2107 7' Multi-Spindle	MS1	18
2208 8' Multi-Spindle	MS2	19
2310 10' Multi-Spindle	MS3	20
3308-2 8' Multi-Spindle	MS4	21
3308SH-2 8' Sing-Hitch Multi-Spindle	MS4	21
MS3110 10' Multi-Spindle	MS5	22
3514 14' Multi-Spindle	MS6	23
14215 15' Multi-Spindle	MS7	24
Multi-Spindle Spec Comparison Chart	MS8	25

FLEX-WING ROTARY CUTTERS

1812 12' Flex-Wing	FW1	28
1815 15' Flex-Wing	FW2	29
2120 20' Flex-Wing	FW3	30
3112 12' Flex-Wing	FW4	31
2215 15' Flex-Wing	FW5	32
2814 14' Single Flex-Wing	FW6	33
2820 20' Flex-Wing	FW7	34
4110 10' Flex-Wing	FW8	35
4115 15' Flex-Wing	FW9	36
5110 10' Flex-Wing	FW10	37
5115 15' Flex-Wing	FW11	38
Flex-Wing Spec Comparison Chart	FW12	39

CROP FLAIL SHREDDERS

BRC Series Crop Flails	FS1	42
Crop Flail Spec Comparison Chart	FS2	43

BOOM MOWERS

PT5 & RMB Series Rear-Mounted Boom Mowers	BM1	46
Forward-Reach Rear-Mounted Boom Mowers	BM2	47
Boom Mower Spec Comparison Chart	BM3	48

SKID STEER BRUSH CUTTERS

BCSS Series Closed-Front Brush Cutters	BC1	50
BCSS Series Open-Front Brush Cutters	BC2	51
Brush Cutter Spec Comparison Chart	BC3	52

CONSTRUCTION IMPLEMENTS

DSP Series Pull Dirt Scrapers	CS1	54
PHD Series Post Hole Diggers	CS2	55
PHDH Series Hydraulic Post Hole Diggers	CS3	56
XD Series Backhoes	CS4	57
AGR, BGR, & BRGR Series Grapples	CS5	58
PFD Series Pallet Forks	CS6	59
SSB & EB Series Buckets	CS7	60

LANDSCAPE IMPLEMENTS

Compact Implements	LS1	62
Blades	LS2	63
BHQA Series Quick Hitches	LS3	64
CP Series Cultipackers	LS4	65
RG, HDRG, & BHCG Series Road Graders	LS5	66
LLR & MLR Series Landscape Rakes	LS6	67
PVB & PVS Series Pulverizers	LS7	68
PG & MPG Series Pluggers	LS8	69
FSP Series Fertilizer & Seed Spreaders	LS9	70
MS Series Manure Spreaders	LS10	71

TILLAGE IMPLEMENTS

RTC Series Compact Tillers	TL1	74
RTG Series Tillers	TL2	75
RTX Series Heavy-Duty Tillers	TL3	76
1D, 2D, & 3D Series Lift Disc Harrows	TL4	77
DHP Series Pull Disc Harrows	TL5	78
APP Series All-Purpose Plows	TL6	79
LP Series Layoff Plows	TL7	80
HDSS Series Heavy-Duty Subsoilers	TL8	81
SS Series Subsoilers	TL9	82
RCV Series Cultivators	TL10	83
PA Series Pasture Aerators	TL11	84

HAY TOOLS

DHM Series Hay Mowers	HT1	86
HT Series Hay Tedders	HT2	87
XLRR-I Series Pull-Type V-Rakes	HT3	88
EWR Series Pull Type V-Rakes	HT4	89
3PB Series Bale Implements	HT5	90
BSS & BSE Series Tractor-Mounted Bale Spears	HT6	91

SNOW REMOVAL EQUIPMENT

SBSA Series Single Auger Snow Blowers	SB1	94
SBDA Series Dual Auger Snow Blowers	SB2	95
SBSS Series Skid Steer Snow Blowers	SB3	96
Snow Blower Spec Comparison Chart	SB4	97

This page intentionally left blank.

SERIES: HDTH | TDC



FINISHING MOWERS



FINISHING MOWERS

HDTH SERIES

FINISHING MOWERS



HP REQUIRED
15 - 35 HP



CUTTING HEIGHT
1 1/2" - 6 1/2"



HITCH TYPE
CAT 1, 2 &
QH READY

MODELS: **HDTH5** | **HDTH6** | **HDTH7** | **HDTH8**



GET SPECIFICATIONS
AND ADDITIONAL
PRODUCT FEATURES

Powerful but smooth even in the toughest grasses!

Turn your tractor into a lawn mowing machine with the HDTH Finish Mowers from Bush Hog®. These Finish Mowers deliver superior grass cutting performance for your well-kept lawn. With models ranging from 5' to 8'-3", our HDTH Finish Mowers help you save time spent cutting your lawn and more time enjoying it. Built Bush Hog® tough in Selma, AL, our HDTH Finish Mowers are manufactured to the highest quality standards for durability and performance, and stringently tested to the Industry Standard Safety Specifications from ASABE, ISO, and ANSI/OPEI.

FEATURES



Optional Front Roller

- 1 year limited warranty with a 5 year gearbox warranty
- 5' - 8' 3" cutting widths
- Minimum required HP of 15 - 35 to meet the needs of today's smaller, compact tractors
- Quick Hitch compatibility on all models allows for easier hook up
- Dual floating hitch points allow the mower to rise and fall with the contour of terrain
- Blade Tip Speeds over 18,200 feet per minute ensure a clean cut every time
- 1 1/2" blade overlap eliminates streaking
- Easy cutting height adjustment, which ranges from 1 1/2" to 6 1/2"
- New dove-tail rear discharge design steadily slopes downward eliminating the need for any type of chain shielding, thereby reducing the possibility of clumping or thrown objects



TDC SERIES TRI-DECK FINISHING MOWERS



HP REQUIRED
25 - 35 HP



CUTTING HEIGHT
1" - 5"



HITCH TYPE
CAT 1, 2,
DRAWBAR

MODELS: TDC-1200 | TDC-1500 | TDC-1700



GET SPECIFICATIONS
AND ADDITIONAL
PRODUCT FEATURES

Durable Features & Reliable Design – For a Fine Finish Cut Acre After Acre

The Bush Hog® TDC Series Tri-Deck Finishing Mower delivers a superior cut across large mowing zones and is ideal for residential and professional use. Built rugged to last, the TDC series offers you the dynamic control features necessary to achieve a fine cut over a variety of terrains. Mowing widths from 12' - 17' that make short work of large expanses are equally complemented by adjustable wings that flex and float over uneven ground for a finely groomed appearance.

FEATURES

- 12', 15', 17' mowing widths
- Adjustable cutting height: 1" - 5"
- Single action hydraulic folding wings
- Adjustable telescoping wings – control overlap
- Completely independent free-floating decks
- High blade tip speed with precision overlap
- Heavy-duty transport frame
- Stamped steel reinforced wheel arms
- Stamped steel wheel yokes
- 8 gauge reinforced decks
- Heavy-duty, one-piece, steel pulleys
- Heavy-duty reinforced belts



Find more product features and options at [BUSHHOG®.com](https://www.bushhog.com)



BUSH HOG® FINISHING MOWERS

SPECIFICATION COMPARISON

	HDTH5	HDTH6	HDTH7	HDTH8	TDC-1200	TDC-1500	TDC-1700
CUTTING WIDTH	5'	6'	7'	8' 3"	12'	15'	17'
CUTTING HEIGHT	1 ½" - 6 ½" (1/2" Increments)	1 ½" - 6 ½" (1/2" Increments)	1 ½" - 6 ½" (1/2" Increments)	1 ½" - 6 ½" (1/2" Increments)	1" - 5" (1/4" Increments)	1" - 5" (1/4" Increments)	1" - 5" (1/4" Increments)
TRACTOR HP RANGE	15 - 35 PTO	20 - 40 PTO	30 - 55 PTO	35 - 55 PTO	25 - 80 PTO	30 - 80 PTO	35 - 80 PTO
HITCH TYPE	Cat 1 Std & QH	Cat 1 Std & QH	Cat. 1, Cat. 2 Std & QH	Cat. 1, Cat. 2 Std & QH	Drawbar	Drawbar	Drawbar
NUMBER OF BLADES	3	3	3	5	3 Per Deck (9 Total)	3 Per Deck (9 Total)	3 Per Deck (9 Total)
BLADE TIP SPEED	17,332 FPM	17,421 FPM	17,812 FPM	17,584 FPM	15,747 FPM	16,863 FPM	16,732 FPM
DRIVELINE	ASAE Cat. 3	ASAE Cat. 3	ASAE Cat. 3	ASAE Cat. 3	Cat. 6 Constant Velocity with Slip Clutch	Cat. 6 Constant Velocity with Slip Clutch	Cat. 6 Constant Velocity with Slip Clutch
DISCHARGE	Rear	Rear	Rear	Rear	Rear	Rear	Rear
DECK THICKNESS	7-Gauge Steel Plate	7-Gauge Steel Plate	7-Gauge Steel Plate	7-Gauge Steel Plate	8-Gauge Steel Plate	8-Gauge Steel Plate	8-Gauge Steel Plate
TIRES	3 ¼x10 Solid	3 ¼x10 Solid	4x10 Solid	5x13 Solid	20.5x8 - 10 Highway Rated	20.5x8 - 10 Highway Rated	20.5x8 - 10 Highway Rated
GEARBOX (HP)	45	45	55	55	Splitter: 80 Mower Deck: 50	Splitter: 80 Mower Deck: 50	Splitter: 80 Mower Deck: 50
APPROXIMATE WEIGHT (LB)	672	730	954	1,190	2,742	2,874	2,995
LIMITED WARRANTY (YRS)	1	1	1	1	1	1	1

Specifications and design subject to change without notice.



Find more product specifications, features and options at [BUSHHOG®.com](https://www.bushhog.com)

SERIES: BH110 | BH210-2 | BH310-2 | BH410 | BH510



SINGLE-SPINDLE

ROTARY CUTTERS



SINGLE-SPINDLE ROTARY CUTTERS

BH110 SERIES SINGLE-SPINDLE ROTARY CUTTERS



HP REQUIRED
15-25 HP



CUTTING CAPACITY
1" DIAM



HITCH TYPE
CAT 1 & QH
COMPATIBLE

MODELS: **BH114** | **BH115** | **BH116**

10
YEAR
GEARBOX LIMITED
WARRANTY



GET SPECIFICATIONS
AND ADDITIONAL
PRODUCT FEATURES

The New BH110 Series picks up where the popular Razorback Series left off. Bush Hog®'s legendary durability and reliability is enhanced even further in the new light-duty BH110 Series. We've taken our quality to a new level in the BH110 Series by robotically welding the entire cutter. The BH110 series is available in 3'8", 4'8", 5'8" cutting widths. All welding is performed on the underside of the deck giving these cutters a clean, sleek appearance. All welds are applied at the same temperature, angle, and duration to ensure consistency from start to finish. Additional enhancements include a stronger gearbox stand and tailwheel caster fork, optional front chain shielding, and optional Category 1 Quick Hitch. The economically priced BH110 Series allows customers with lower horsepower compact tractors to take control of pesky weeds, grass, and small brush up to 1" in diameter while experiencing legendary Bush Hog® performance. As thousands of satisfied customers can attest, if it doesn't say Bush Hog®, it just won't cut it!

FEATURES



The economically priced BH110 Series allows customers to take control of pesky weeds, grass, and small brush up to 1" in diameter while experiencing legendary Bush Hog® performance.

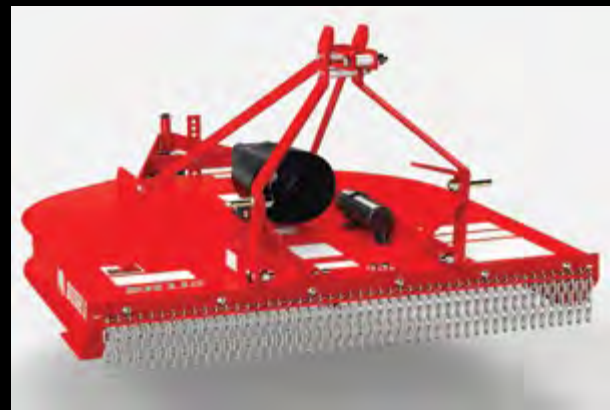

BH115 shown with optional Quick Hitch and Front Chains



BH210-2 SERIES SINGLE-SPINDLE ROTARY CUTTERS



HP REQUIRED
25 - 50 HP



CUTTING CAPACITY
2" DIAM



HITCH TYPE
CAT 1 - 2
& QH READY

MODELS: **BH215-2** | **BH216-2** | **BH217-2**



10
YEAR
GEARBOX LIMITED
WARRANTY



GET SPECIFICATIONS
AND ADDITIONAL
PRODUCT FEATURES

FEATURES



Building on the success of the original BH210 Series, the new, updated BH210-2 Series Rotary Cutters combine the legacy and reputation of Bush Hog®'s Single-Spindles with new, innovative design updates. These updated cutters now have full-length strongbacks designed to reinforce the entire length of the cutter, front to back, especially enhancing the rear half of the cutter and tailwheel structure. Reinforcement plates have been added to the bottom of the rear sidebands, providing extra strength in this critical area when backing into vegetation. Tall grass, pesky weeds, and small brush are no match for these authentic Bush Hog® built cutters. Available in 5', 6', and 7' cutting widths, the BH210-2 Series Rotary Cutters are "Made in America" and designed to deliver superior performance in tough conditions, day after day, and year after year.

- Full-length 10ga strongbacks under the cutter reinforce the entire structure adding strength where you need it most
- Rear sideband support plates add strength to the rear of the cutter when backing into material.
- 1/4" Skids run half the length of the cutter to protect the sidebands and add strength and stiffness.
- Rear band is continuously welded and curved to add strength and resist bending.
- Formed tailwheel bracket is fully welded to the deck providing superior strength during punishing vertical and horizontal loads.



Find more product features and options at **BUSHHOG®.com**

BH310-2 SERIES SINGLE-SPINDLE ROTARY CUTTERS



HP REQUIRED
35-55 HP



CUTTING CAPACITY
3" DIAM



HITCH TYPE
CAT 1-3
& QH READY

MODELS: **BH315-2** | **BH316-2** | **BH317-2**



10
YEAR
GEARBOX LIMITED
WARRANTY



GET SPECIFICATIONS
AND ADDITIONAL
PRODUCT FEATURES

The BH310-2 Series picks up where the BH210-2 Series trails off. Built with similar (but heavier-duty) design and features as the BH210-2 Series, the BH310-2 Series has larger gearboxes, stronger decks, full-length 7ga strongbacks, stronger sidebands and hitch structure. Heavy grass, weeds, and medium-sized brush and saplings are no match for these authentic Bush Hog® built cutters. Available in 5', 6' and 7' cutting widths, the BH310 Series Rotary Cutters are designed to deliver superior performance in tough conditions, day in and day out.



FEATURES



- Full-length 7ga strongbacks under the cutter reinforce the entire structure adding strength where you need it most.
- Taller sidebands allow more material and airflow under the deck increasing cutting volume and clipping efficiency.
- Replaceable 1/4" skids run half the length of the cutter to protect the sidebands and add strength and stiffness.
- Rear band is continuously welded and curved to add strength and resist bending.
- Formed tailwheel bracket is fully welded to the deck providing superior strength during punishing vertical and horizontal loads.



BH410 SERIES SINGLE-SPINDLE ROTARY CUTTERS

HP REQUIRED
60 HP | 70 HP

CUTTING CAPACITY
4" DIAM

HITCH TYPE
CAT 2-3
& QH READY

MODELS: **BH416** | **BH417**

10
YEAR
GEARBOX LIMITED
WARRANTY



GET SPECIFICATIONS
AND ADDITIONAL
PRODUCT FEATURES

Heavy-Duty Single Spindle Cutter

Thick pastures, roadsides, gas and power line right-of-ways are no match for these authentic Bush Hog® built cutters. Available in 6' and 7' cutting widths, the BH410 Series Rotary Cutters are designed and built to take down virtually any unwanted vegetation. Whether you're a professional cutting every day or a weekend warrior tackling tough jobs on the farm, these cutters will be with you every step of the way.



FEATURES



- Full-length 7ga strongbacks under the cutter reinforce the entire structure adding strength where you need it most
- Strongbacks and gearbox stand are located under the deck creating a smooth-top for easy cleaning.
- Taller sidebands allow more material and airflow under the deck increasing cutting volume and clipping efficiency.
- Replaceable 1/4" skids run half the length of the cutter to protect the sidebands and add strength and stiffness.
- Rear band is continuously welded and curved to add strength and resist bending.
- Gusseted tailwheel bracket is reinforced in critical wear areas to provide increased strength and durability.
- Available with heavy-duty galvanized deck



Find more product features and options at [BUSHHOG®.com](https://www.bushhog.com)

BH510 SERIES SINGLE-SPINDLE ROTARY CUTTERS



HP REQUIRED
70 HP



CUTTING CAPACITY
5" DIAM



HITCH TYPE
CAT 2 - 3
& QH READY

MODELS: **BH516**

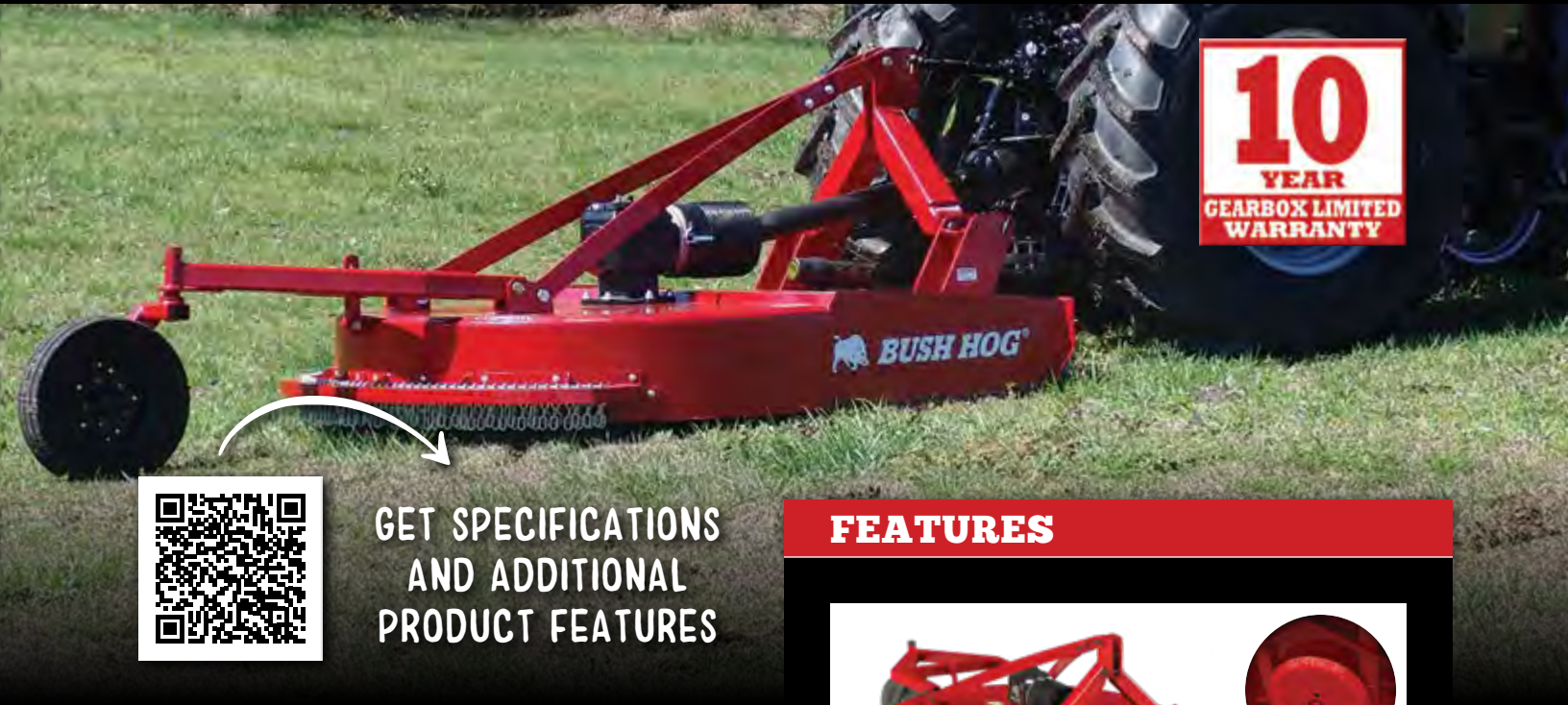

10
YEAR
GEARBOX LIMITED
WARRANTY



GET SPECIFICATIONS
AND ADDITIONAL
PRODUCT FEATURES

Extreme-Duty Brush Cutter

The BH516 is the flagship of our Single-Spindle lineup. Thick pastures, gas and power line right of ways, roadsides, practically even small forests are no match for these authentic Bush Hog® built cutters. The Extreme-Duty BH516 Rotary Cutter is designed and built to take down virtually any unwanted vegetation. Whether you're a professional cutting every day or a weekend warrior tackling tough jobs on the farm, these cutters will be with you every step of the way. These cutters truly embody our motto: "If it doesn't say Bush Hog®, it just won't cut it."



FEATURES



Hardened, hex-shaped blade bolts with mating hardened bushings and reinforced blade pans

- Reinforced 7ga strongbacks and gearbox stand are integrated together and located under the deck creating a smooth-top for easy cleaning.
- Taller sidebands allow more material and airflow under the deck increasing cutting volume and clipping efficiency.
- 1/4" Skids run half the length of the cutter to protect the sidebands and add strength and stiffness.
- Rear Band is continuously welded and curved to add strength and resist bending.
- Available with heavy-duty galvanized deck





BUSH HOG® SINGLE-SPINDLES

SPECIFICATION COMPARISON

	4'				5'					6'				7'		
	BH114	BH115	BH215-2	BH315-2	BH116	BH216-2	BH316-2	BH416	BH516	BH217-2	BH317	BH417				
CUTTING WIDTH	3' 8"	4' 8"	5'	5'	5' 8"	6'	6'	6'	6'	7'	7'	7'				
CUTTING HEIGHT	1 ½" - 11"	1 ½" - 11"	1 ½" - 12"	1 ½" - 12"	1 ½" - 11"	1 ½" - 12"	1 ½" - 12"	1 ½" - 12"	1 ½" - 12"	1 ½" - 12"	1 ½" - 12"	1 ½" - 12"				
CUTTING CAPACITY	1"	1"	2"	3"	1"	2"	3"	4"	5"	2"	3"	4"				
HITCH TYPE*	Cat 1 Std & QH	Cat 1 Std & QH Opt	Cat 1 Std & QH	Cat 1 or 2 Std & QH	Cat 1 Std	Cat 1 Std & QH	Cat 1 or 2 Std & QH	Cat 2 or 3 Std & QH	Cat 2 or 3 Std & QH	Cat 1 or 2 Std & QH	Cat 2 or 3 Std & QH	Cat 2 or 3 Std & QH				
DECK THICKNESS (GA)	12	12	11	10	12	10	10	7	7	10	10	7				
SIDEBANDS (GA)	10	10	11	1/4"	10	10	1/4"	1/4"	1/4"	10	1/4"	1/4"				
SIDEBAND HEIGHT (IN)	8	8	11 ½	11 ½	8	11 ½	11 ½	13	13	11 ½	11 ½	13				
DRIVELINE	Cat 3	Cat 3	Cat 3	Cat 4	Cat 3	Cat 3	Cat 4	Cat 5	Cat 6	Cat 4	Cat 4	Cat 6				
DRIVELINE PROTECTION **	Shearpin or Slip-Clutch	Shearpin or Slip-Clutch	Shearpin or Slip-Clutch	Slip-Clutch	Shearpin or Slip-Clutch	Shearpin or Slip-Clutch	Slip-Clutch	Slip-Clutch	4 Plate Slip-Clutch	Slip-Clutch	4 Plate Slip-Clutch	4 Plate Slip-Clutch				
GEARBOX RATING (PTO)	60	60	65	130	60	65	130	210	225	130	130	210				
TRACTOR PTO SPEED	540	540	540	540	540	540	540	540	540	540	540	540				
MINIMUM TRACTOR PTO HP	15	20	25	35	25	30	45	60	70	50	55	70				
BLADE HOLDER	Oval	Oval	Oval	Round	Oval	Oval	Round	Round	Round	Oval	Round	Round				
BLADES (IN)	1/2x3 Uplift	1/2x3 Uplift	1/2x4 Uplift	1/2x4 Uplift	1/2x3 Uplift	1/2x4 Uplift	1/2x4 Uplift	1/2x4 Uplift	1/2x5 Uplift	1/2x4 Uplift	1/2x4 Uplift	1/2x4 Uplift				
BLADE TIP SPEED (FPM)	15,904	15,472	14,335	14,506	14,307	14,963	14,861	13,997	13,346	14,370	14,370	14,488				
TIRES	14 ½" Laminated	14 ½" Laminated	15 ½" Laminated	15 ½" Laminated	14 ½" Laminated	15 ½" Laminated	15 ½" Laminated	21" Laminated	21" Laminated	15 ½" Laminated	15 ½" Dual Laminated	21" Dual Laminated				
FRONT DEFLECTOR TYPE	Rubber Std; Chains Op	Rubber Std; Chains Op	Rubber or Single Chains	Rubber; Single or Double Chains	Rubber Std; Chains Op	Rubber or Single Chains	Rubber; Single or Double Chains	Single or Double Chains	Double Chains Only	Rubber or Single Chains	Rubber; Single or Double Chains	Single or Double Chains				
REAR DEFLECTOR TYPE	Metal Band	Metal Band	Metal Band or Single Chains	Metal Band; Single or Double Chains	Metal Band	Metal Band or Single Chains	Metal Band; Single or Double Chains	Single or Double Chains	Double Chains Only	Metal Band or Single Chains	Metal Band; Single or Double Chains	Single or Double Chains				
APPROXIMATE WEIGHT (LB.)	400	500	655	994	600	804	1171	1300	1775	1036	1517	2000				
GEARBOX WARRANTY (YRS)	10	10	10	10	10	10	10	10	10	10	10	10				

* Cat 2 Std with optional bushings

** 2 plate slip-clutch driveline protection unless noted otherwise

Specifications and design subject to change without notice.



Find more product specifications, features and options at **BUSHHOG.com**

This page intentionally left blank.

SERIES: 2000 | 3000 | 4200



MULTI-SPINDLE ROTARY CUTTERS



MULTI-SPINDLE ROTARY CUTTERS

2107 MULTI-SPINDLE ROTARY CUTTER



HP REQUIRED
30 HP



CUTTING CAPACITY
2" DIAM



HITCH TYPE
CAT 1-2
& QH READY

10
YEAR
GEARBOX LIMITED
WARRANTY

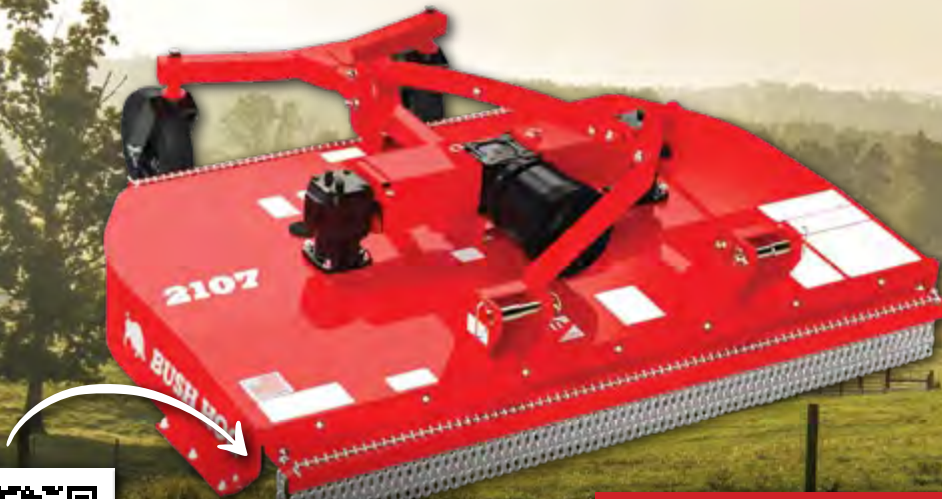

GET SPECIFICATIONS
AND ADDITIONAL
PRODUCT FEATURES

When you want the widest cutting width possible for your lower horsepower tractor, our 2107 multi-spindle has you covered. The 2107 is perfect for general mowing applications such as pastures, overgrown fields, and hunting camps, and is also a perfect fit for orchards and vineyards where planted rows are getting closer together to maximize space and yield. With deeper sidebands and cutting gearboxes providing approximately 16,000 feet per minute blade tip speeds, the 2107 slashes through dense vegetation with ease. Stronger deck components such as a 10ga top plate, extensive structural tubing framework, 7ga sidebands, and reinforced hitch components instill confidence in the product's durability and longevity. And as with all Bush Hog® rotary cutters, the 2107 comes with the industry's only 10-Year Gearbox Limited Warranty, so you can buy with confidence. If the 2107 fits your needs and application, give it a try and understand why "If it doesn't say Bush Hog®, it just won't cut it."

FEATURES



Available with Single Tailwheel for a tighter turning radius or Dual Tailwheels for more stability



Durable rubber discs protect cross shafts from harsh impacts and loads

- Reliable Bush Hog® Performance In An Economical 3-Point Lift-Type Mower
- 7' 2" Cutting Width
- Durable Rubber Discs in Cross Shafts
- Front Single or Double Row Chains
- Rear Metal Band, Single or Double Row Chains
- 7 Gauge Oval Blade Pans
- EZ-Clean Smooth, Sloped Deck
- Cat. 1 & 2 Standard & Quick Hitch
- High Blade Tip Speeds
- 10-Year Gearbox Limited Warranty
- Improved Compatibility with Compact Tractor due to specifically designed Front to Rear Length



2208 MULTI-SPINDLE ROTARY CUTTER



HP REQUIRED
35-45 HP



CUTTING CAPACITY
2" DIAM



HITCH TYPE
CAT 1-2 & QH,
SEMI-MOUNT, PULL

10
YEAR
GEARBOX LIMITED
WARRANTY



GET SPECIFICATIONS
AND ADDITIONAL
PRODUCT FEATURES

The 2208 cutter is designed for general purpose cutting of fields, crop residue, and light brush up to 2" in diameter. Cutting efficiency is increased by the 8' 3" cutting width and 11 3/4" sideband height allowing a greater volume of material within the cutting chamber. Then, higher blade tip speeds shred through tough vegetation for a clean cut of material with excellent distribution. The pull-type model comes equipped with an ASAE Category 4 CV driveline, rubber cushioned axles, and 21" laminated tires. And with a tongue weight of only 880 lb., the 2208 pull-type is easier on tractor drawbars, effectively powered by tractors with only 35HP. An optional heavy-duty Hydraulic Cylinder allows for on-the-go cutting height adjustment, while an easy to adjust tension rod allows for leveling the cutter from front to back. The 2208 lift-type comes equipped as a Cat 1 & 2 standard and quick hitch, ASAE Category 4 driveline, twin beam axles, and 15 1/2" Laminated Tires. At only 8' 6" front to back, the 2208 Lift-Type is perfect for areas where a tighter turning radius is required.

FEATURES



Heavy-duty frame
and gearbox stand
construction



Durable rubber discs
protect cross shafts from
harsh impacts and loads



Heavy duty pull-type axle
with 21" laminated tires



Twin beam axles on lift
and semi-mount models
with 15 1/2" laminated tires



Self-leveling pull-type
with reinforced axles
and tongue



Find more product features and options at **BUSHHOG®**.com

2310 MULTI-SPINDLE ROTARY CUTTER



HP REQUIRED
50-70 HP



CUTTING CAPACITY
2" DIAM



HITCH TYPE
CAT 2-3 & QH,
SEMI-MOUNT, PULL

10
YEAR
GEARBOX LIMITED
WARRANTY

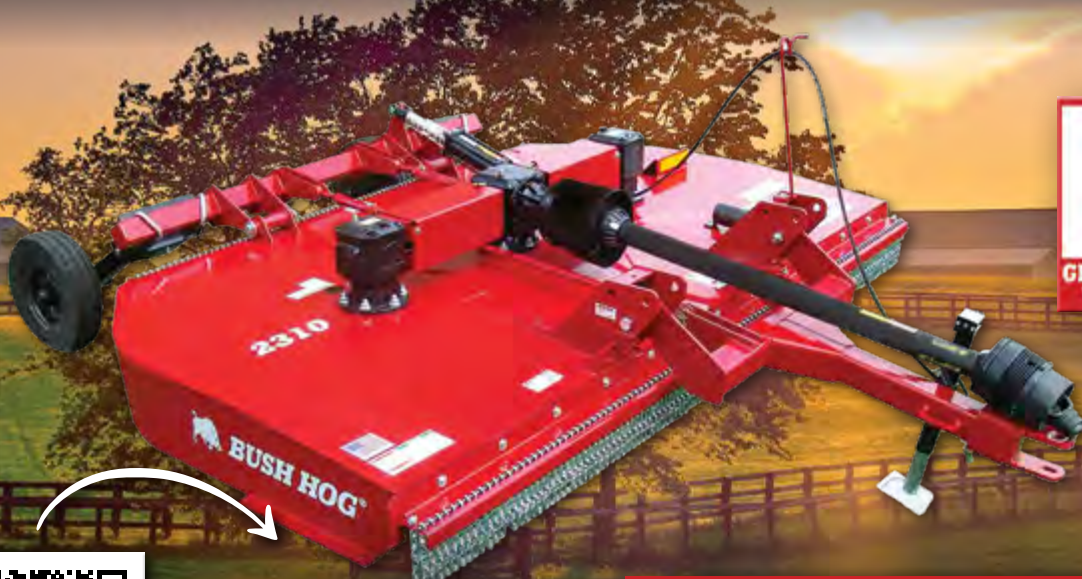

GET SPECIFICATIONS
AND ADDITIONAL
PRODUCT FEATURES

The 2310 multi-spindle rotary cutter slashes through heavy grass, weeds, and light brush up to 2" in diameter. Available in 3-point lift-type, semi-mount and Self-Leveling Pull-Type models, the 2310 makes quick work of crop residue, orchard maintenance, and general land overgrowth. And when you're finished cutting, the smooth-top deck makes cleanup a snap.

FEATURES



Fully-welded, narrow tongue allows for tighter turning radius



Durable rubber discs protect cross shafts from harsh impacts and loads

- 10 Year Gearbox Limited Warranty
- Smooth-Top Deck
- Quick-Detach Gearbox Shields
- 10 gauge Deck
- 7 Gauge Steel Sidebands
- Tough Slip-Clutches Standard
- Round Blade Pans Standard
- Front Single or Double Row Chains
- Rear Band or Single or Double Row Chains
- Driveline Shields



3308-2 MULTI-SPINDLE ROTARY CUTTERS



HP REQUIRED
40-50 HP



CUTTING CAPACITY
3" DIAM



HITCH TYPE
CAT 1-2 & QH,
SEMI-MOUNT, PULL

MODELS: 3308-2 | 3308SH-2

10
YEAR
GEARBOX LIMITED
WARRANTY



GET SPECIFICATIONS
AND ADDITIONAL
PRODUCT FEATURES

The 3308-2 models are designed to cut heavy grass, weeds, and brush up to 3" in diameter. The lift and semi-mount models are available with economical twin beam axles or heavy duty cushioned axles. The pull-type and the swing-hitch models have heavy-duty axles as standard for durability and a smoother ride.

The 3308-2 models deliver what you would expect from Bush Hog®, which is rugged durability and excellent performance. The 3308SH has a hydraulic cylinder to offset the cutter 13" to the right of the tractor centerline. Extending farther beyond the tractor tires is ideal in orchards and hard to reach areas near ditches. Deep sidebands provide better cutting performance in extra heavy growth conditions.

FEATURES



3308SH-2 Swing-Hitch Model

- 8' 3" Cutting Width
- Lift, Pull & Semi-Mount Models
- Swing-Hitch Model Ideal For Orchards
- Durable Cross Shafts
- Heavy Rugged Deck Structure
- Safety Tow Chain (Standard on Pull Model)
- Safety Shields Combination of Front and Rear Chains and Rear Band
- 10-Gauge Deck Construction
- 7-Gauge Strongbacks
- 1/4" Sidebands
- 10 Year Gearbox Limited Warranty



Find more product features and options at **BUSHHOG®.com**

MS3110 MULTI-SPINDLE ROTARY CUTTER



HP REQUIRED
60-75 HP



CUTTING CAPACITY
3 1/2" DIAM



HITCH TYPE
CAT 2-3 & QH,
SEMI-MOUNT, PULL



10
YEAR
GEARBOX LIMITED
WARRANTY



GET SPECIFICATIONS
AND ADDITIONAL
PRODUCT FEATURES

The New MS3110 Multi-Spindle Rotary Cutter honors the legacy of the 3510, but kicks it up a notch! With a 10' 6" cutting width, the MS3110 will help you get through mowing jobs faster. The deck structure has been upgraded with new structural tube strongbacks, improved gearbox stands, taller sideband height and throat opening for increased mowing volume, and a stronger 7ga smooth-top deck that is easy to clean and will last for many years. Durable cross-shafts transfer power to the cutting gearboxes, while providing shock protection against unexpected obstacles. Pull-type axles incorporate perfect-match rubber isolators to be more like our new Flex-Wing-style, which improves ride comfort and shock reduction. The new heavy-duty Lift-Type axle uses rubber isolators to reduce shock into the axle and deck, while the new and improved dual-fork swivel caster design increases maneuverability and durability. Cutting efficiency and clipping distribution has been improved by utilizing precisely placed baffles to direct cut material across the entire width of the rear of the cutter.

FEATURES



Heavy-Duty deck structure designed for improved rigidity, cutting efficiency, and extra long life



Lift-Type models feature strengthened Cat 2 or 3 3-Point Hitches and are Quick Hitch ready



Improved Lift-type and Semi-Mount Axles feature custom rubber isolators and new, stronger swivel caster forks



Pull models feature new cushioned axles with Flex-Wing style inserts for increased durability and maintenance ease



3514 MULTI-SPINDLE ROTARY CUTTER



HP REQUIRED
75-90 HP



CUTTING CAPACITY
3 1/2" DIAM



HITCH TYPE
CAT 2-3 & QH,
SEMI-MOUNT, PULL



10
YEAR
GEARBOX LIMITED
WARRANTY



GET SPECIFICATIONS
AND ADDITIONAL
PRODUCT FEATURES

The heavy duty 3514 cuts a 14 foot swath and is ideal for grass, weeds and row crop shredding. Available as a lift or pull model with round blade carriers or straight blade bars and an optional shredding kit, this wide unit covers ground quickly and delivers top cutting performance.

FEATURES



Rubber cushioned axle arms are standard equipment on the 3514 model cutters and do an excellent job of absorbing shock loads when operating on rough terrain.



Wheel axles are attached by heavy duty pivot pins with replaceable bushings that extend through the cutter strongbacks. This dependable mounting arrangement provides extra strength and less pivot pin wear.

- Rated for Min. 90 HP Tractors
- Available With Row Crop Shredding Kit
- Rubber Element Cross Shafts
- Heavy Duty Rubber Cushioned Axles
- High Blade Tip Speeds
- Three Round Or Straight Blade Holders
- Slip Clutch Standard



Find more product features and options at **BUSHHOG®.com**

14215 MULTI-SPINDLE ROTARY CUTTER



HP REQUIRED
125 HP



CUTTING CAPACITY
3 1/2" DIAM



HITCH TYPE
CAT 2-3 & QH

10
YEAR
GEARBOX LIMITED
WARRANTY



**GET SPECIFICATIONS
AND ADDITIONAL
PRODUCT FEATURES**

The Bush Hog® 14215 is a row crop and pasture maintenance beast! This 15' multi-spindle makes short work of cutting unwanted crop residue and pasture overgrowth. This cutter differs from conventional multi-spindle cutters in that it incorporates overlapped but non-timed cutting circles. This design allows for each gearbox to have slip-clutch protection in lieu of rigid cross-shafts found on other multi-spindle cutters. Axle arms can be positioned precisely to specific row spacings. The galvanized deck provides extra rust protection in environments such as crop fields and pastures where fertilizer and herbicides are often used. Available as a Lift-Type, 1000RPM unit with round blade pan and 21" laminated tires only. Due to its weight and overall size, this cutter requires at least a 125HP tractor to operate effectively.

FEATURES



- 15-Foot Wide Galvanized Deck
- Offset Cutting Circles Eliminates Blade Timing
- Multi-Plate Slip-Clutches Protect Center and Outboard Gearboxes
- Multi-Position Axle Arms Accommodate Varied Row Crop Spacings
- Heavy-Duty Cat 2 & 3 Standard & Quick Hitch
- 1000RPM 1 3/8" - 21 Input Driveline Only
- 10" Tall Sidebands
- 7ga High-Strength Steel Deck
- 7ga Structural Tube Strongbacks
- 7ga Round Blade Pan/Stump Jumper





BUSH HOG® MULTI-SPINDLES

SPECIFICATION COMPARISON

	2107	2208	2310	3308-2	3308SH-2	MS3110	3514	14215
CUTTING WIDTH	7' 2"	8' 3"	9' 9"	8' 3"	8' 3"	10' 6"	14'	15'
CUTTING HEIGHT	1½" - 11"	1½" - 13"	1½" - 13"	1½" - 13"	1½" - 13"	1½" - 13"	1½" - 13"	1½" - 16"
CUTTING CAPACITY	2"	2"	2"	3"	3"	3½"	3½"	3½"
HITCH TYPE	Cat. 1 & 2 Std & QH	Cat. 1. & 2 Std & QH Semi-Mount Pull	Cat. 2 & 3 Std & QH Semi-Mount Pull	Cat. 1 & 2 Std & QH Semi-Mount Pull	Semi-Mount	Cat. 2 & 3 Std & QH Semi-Mount Pull	Cat. 2 & 3 Std & QH Semi-Mount Pull	Cat. 2 & 3 Std & QH
DECK THICKNESS	10ga	10ga	10ga	10ga	10ga	7ga	10ga	7ga
SIDEBAND THICKNESS	7ga	7ga	7ga	1/4"	1/4"	1/4"	1/4"	1/4"
SIDEBAND HEIGHT	11¾"	11¾"	11¾"	11¾"	11¾"	13"	10"	10"
DRIVELINE SIZE	Cat. 3	Cat. 4	Cat. 4	Cat. 4	Cat. 4	Cat. 5	Cat. 5	Cat. 5
DRIVELINE PROTECTION	2-Plate Slip-Clutch	2-Plate Slip-Clutch	4-Plate Slip-Clutch	4-Plate Slip-Clutch	4-Plate Slip-Clutch	4-Plate Slip-Clutch	4-Plate Slip-Clutch	4-Plate Slip-Clutch
TRANSFER GEARBOX (HP)	140	140	140	140	140	210	210	210
CUTTING GEARBOX (HP)	65	65	130	130	130	210	210	210
TRACTOR PTO SPEED	540	540	540	540	540	540	540 or 1000	1000
MIN. TRACTOR PTO HP	30 (W/ Adequate Front Ballasts)	35 (Pull) 45 (Lift)	50 (Pull) 70 (Lift)	40 (Pull) 50 (Lift)	40	60 (Pull) 75 (Lift)	75 (Pull) 90 (Lift)	125
BLADE HOLDER	Oval Pan	Oval Pan	Round Pan	Round Pan	Round Pan	Round Pan	Round Pan or Shredder Bar	Round Pan
BLADES	1/2" x 4" Uplift	1/2" x 4" Uplift	1/2" x 4" Uplift	1/2" x 4" Uplift	1/2" x 4" Uplift	1/2" x 4" Uplift	1/2" x 4" Uplift	1/2" x 4" Uplift
BLADE TIP SPEED (FPM)	16,000	16,173	15,778	16,121	16,121	16,881	15,138	17,280/15,708
TIRES	15½" Laminated	Lift: 15½" Laminated; Pull: 21" Laminated	Lift: 21" Laminated; Pull: 21" Laminated; 25" Foam; 29" Air	Lift: 15½", 21" Laminated; Pull: 21" Laminated; 25" Foam; 29" Air	21" Laminated	Lift: 21" Laminated; 20.5" Air; Pull: 21" Laminated; 25" Laminated; 25" Foam; 29" Air	Lift: 21" Laminated; Pull: 21" Laminated; 25" Foam	21" Laminated
FRONT DEFLECTOR TYPE	Single or Double Chains	Single or Double Chains	Single or Double Chains	Single or Double Chains	Single or Double Chains	Single or Double Chains	Rubber; Single Chains	Rubber
REAR DEFLECTOR TYPE	Metal Band; Single or Double Chains	Metal Band; Single or Double Chains	Metal Band; Single or Double Chains	Metal Band; Single or Double Chains	Metal Band; Single or Double Chains	Metal Band; Single or Double Chains	Rubber; Metal Band; Single Chains	Metal Band
APPROXIMATE WEIGHT (LB)	1,200	1,650	2,000	1,800	1,900	3,100	3,400	3,700
GEARBOX WARRANTY (YRS)	10	10	10	10	10	10	10	10

Specifications and design subject to change without notice.



Find more product specifications, features and options at **BUSHHOG.com**

SERIES: 1800 | 2100 | 3100 | 2200 | 2800 | 4100 | 5100



FLEX-WING

ROTARY CUTTERS

FLEX-WING ROTARY CUTTERS



1812 FLEX-WING ROTARY CUTTER



HP REQUIRED
50 HP



CUTTING CAPACITY
1 1/2" DIAM



HITCH TYPE
SWIVEL CLEVIS



GET SPECIFICATIONS
AND ADDITIONAL
PRODUCT FEATURES

FEATURES



Replaceable full length sideband skids give maximum protection and strength to the sideband.



Rubber cushion on center section of each axle arm to absorb the shock loads near the wheels. Shown with optional dual tires on the center.



Patented oil sight gauge in all three cutting gearboxes for quick and easy monitoring of oil levels.



Bush Hog's EZ-Lube drivelines are quick and easy to service. All grease fittings on the PTO CV drivelines and wing drivelines closely align for quick location of grease points.

Utility Duty Pasture Flex-Wing

Ideal for rolling terrain where a wide rigid cutter may scalp some areas while leaving other areas higher, the 1812 Flex-Wing Rotary Cutter's 12' cutting width makes quick, clean work of overgrown pastures and fields. The narrow width is also ideal for orchards where tree prunings need to be cut into smaller pieces. The 1812 is designed to effectively cut grass, weeds, and brush up to 1 1/2" diameter with at least 50 tractor PTO horsepower. The 1812 has maintenance-friendly features such as easy to clean smooth-top decks, gearbox oil sight windows, EZ lube drivelines, and replaceable full-length sideband skids. For the best in class cutting and distribution performance in a 12' Flex-Wing, you only have to remember that "If it doesn't say Bush Hog®, it just won't cut it."

The 1812 comes standard with a 540 PTO and Cast Swivel Hitch and choice of Single or Dual Center Axles, Single or Dual Wing Axles, 3 Selections of Tires, and Single or Double Row Chains.



1815 FLEX-WING ROTARY CUTTER



HP REQUIRED
60 HP



CUTTING CAPACITY
2 1/2" DIAM



HITCH TYPE
PERMA-LEVEL



GET SPECIFICATIONS
AND ADDITIONAL
PRODUCT FEATURES

FEATURES



Wing free float is 22° down and 25° up without movement of hydraulic cylinder rod for extended cylinder life.



Each axle arm on the center section has a rubber cushion to absorb the shock loads near the wheel.



Patented oil sight gauge in all three cutting gearboxes for quick and easy monitoring of oil levels.



Bush Hog®'s EZ-Lube drivelines are quick and easy to service. All grease fittings on the PTO CV drivelines and wing drivelines closely align for quick location of grease points.

Medium-Duty Flex-Wing

The Bush Hog® 1815 Flex-Wing Rotary Cutter is designed to cut weeds, grasses, and brush up to 2 1/2" in diameter. A great choice for tractors over 60 PTO HP, the 1815 is an excellent choice for pasture clipping, corn shredding, drainage areas, and general maintenance locations such as air strips and CRP land. The 1815 has maintenance-friendly features such as easy to clean smooth-top decks, gearbox oil sight windows, EZ lube drivelines, and replaceable full-length sideband skids. The 1815 performance to price ratio plus outstanding durability make it a great value and will offer years of dependable service.

The 1815 comes standard with Perma-Level Hitch and Center Dual Axle and choice of 540 or 1000 RPM CV input drivelines, with or without Deck Ring, Single or Dual Wing Axles, 3 Selections of Tires, and Single or Double Row Safety Chains.



Find more product features and options at **BUSHHOG®.com**

2120 FLEX-WING ROTARY CUTTER



HP REQUIRED
70 HP



CUTTING CAPACITY
2" DIAM



HITCH TYPE
PERMA-LEVEL
OR BALL HITCH



GET SPECIFICATIONS
AND ADDITIONAL
PRODUCT FEATURES

Wide-Area Pasture Rotary Cutter

The Bush Hog® 2120 Flex-Wing Rotary Cutter is designed to cut grass, weeds, and brush up to 2" in diameter. The perfect cutter for maintaining large pastures, open parks, and airports, where clipping distribution is paramount for presenting a clean, manicured appearance. Fully-baffled decks increase directional air flow allowing the blades to guide clippings across the entire width of the cutter. EZ-clean decks, EZ-adjust leveling rods, EZ-lube drivelines, and multiple grease points, make maintaining the 2120 a snap. Invest in the 2120, and it will reward you with years of excellent performance and dependable service.

The 2120 comes standard with our Perma-Level Hitch and Single Row Chains, along with your choice of 540 or 1,000RPM CV Input Drivelines, Center Dual or Walking Tandem Axles, Wing Single, Dual, or Walking Tandem Axles, and 5 Selections of tires.

FEATURES



Our Wing Free Float feature allows for 22° down and 25° up travel without movement of hydraulic cylinder rod for extended cylinder life.



Each axle arm is spring-loaded to absorb shock loads that could transfer through the axle and deck.



The 2120 is equipped with distribution baffles to evenly spread out clippings across the width of the cutter.



Our Patented oil sight gauges in all three cutting gearboxes allow for quick and easy oil level checks.



3112 FLEX-WING ROTARY CUTTER



HP REQUIRED
55 HP



CUTTING CAPACITY
3 1/2" DIAM



HITCH TYPE
PERMA-LEVEL+

10
YEAR
GEARBOX LIMITED
WARRANTY



GET SPECIFICATIONS
AND ADDITIONAL
PRODUCT FEATURES

New Heavy-Duty 12' Flex-Wing

The 3112 is a versatile, heavy-duty 12' Flex-Wing that continues the pedigree of our larger, commercial Flex-Wings. Taking design cues from our 4115, the 3112 is built to perform in a variety of applications from routine pasture and orchard mowing to roadside maintenance. Designed to cut heavy grasses and brush up to 3 1/2" in diameter, these mowers get the job done in virtually any environment. It is equipped with the latest performance and convenience features like durable, stoutly-braced 10ga Decks, 1/4" Sidebands, 7ga Round Blade Pans, 1/2" x 4" blades with 8" overlap to ensure impeccable cut quality, dual EZ-adjust leveling rods, and 1/2" thick replaceable cast wing skids. Each axle arm contains custom shock absorbing isolators to glide over obstacles, while significantly reducing shock loads for an improvement you can feel in the tractor seat. 130HP gearboxes are integrated into heavily gusseted stands that resist torsional forces and impacts.

FEATURES



Available with or without Deck Rings



Heavy-Duty axles are cushioned by custom-tuned rubber isolators in each axle arm



130HP gearboxes are driven by Cat 4 Wing Drivelines with slip-clutches



Our Patent-Pending Driveline Assist carries the load when connecting the heavy Cat 6 CV driveline to the tractor PTO



Find more product features and options at **BUSHHOG®.com**

2215 FLEX-WING ROTARY CUTTER



HP REQUIRED
60 HP



CUTTING CAPACITY
3 1/2" DIAM



HITCH TYPE
PERMA-LEVEL

10
YEAR
GEARBOX LIMITED
WARRANTY



GET SPECIFICATIONS
AND ADDITIONAL
PRODUCT FEATURES

Medium-Plus Duty Flex-Wing

The 2215 is designed to cut grass, weeds, and brush up to 3 1/2" in diameter. It is recommended for use in pasture maintenance, crop shredding, and roadside maintenance. With maintenance friendly features such as EZ clean decks, EZ-Lube drivelines and Bush Hog® tough durability, the 2215 is another example of Bush Hog® Performance You Can Count On.

The 2215 comes standard with perma-level hitch and choice of 540 or 1000 RPM CV input drivelines, with or without deck ring, center dual or walking tandem axles, wing single, dual, or walking tandem axles, 5 tire selections, and single or double row safety chains.

FEATURES



Each axle arm on the center and wings has a spring cushion to absorb the shock loads near the wheel.



Patented oil sight gauge in all three cutting gearboxes for quick and easy monitoring of oil levels.



Bush Hog®'s EZ-Lube drivelines are quick and easy to service. All grease fittings on the PTO CV drivelines and wing drivelines closely align for quick location of grease points.



2814 FLEX-WING ROTARY CUTTER



HP REQUIRED
90 HP



CUTTING CAPACITY
3" DIAM



HITCH TYPE
PERMA-LEVEL
OR BALL HITCH



10
YEAR
GEARBOX LIMITED
WARRANTY



GET SPECIFICATIONS
AND ADDITIONAL
PRODUCT FEATURES

FEATURES



Heavy-duty blade pans and deck rings protect the cutter and gearbox output shaft from unexpected obstacles and blade deflection.



Bush Hog's EZ-Lube drivelines are quick and easy to service. All grease fittings on the PTO CV drivelines and wing drivelines closely align for quick location of grease points.



The Patented oil sight gauge takes the guess work out of checking the oil. In less than 10 seconds, all three cutting box oil levels can be checked and rechecked as often as you walk around the machine. Never climb onto the cutter again to check the gearbox oil levels.

Heavy-Duty Right-of-Way Single Flex-Wing

The 2814 Single Flex-Wing fits the bill when double wing cutters are prohibited by county or state governments due to the danger of having the left wing stick out into the road. And spanning 14', the 2814 covers a lot of ground. This cutter is packed with performance features like a rugged, center dual deck design, heavy-duty 250HP Transfer Gearbox, dependable 225HP cutting gearboxes with sight windows to quickly and safely check the oil, and independent spring-cushioned suspension at each wheel. The 2814 comes standard with Double Row Chains as recommended for additional safety from thrown objects when mowing along roadsides, as well as Deck Rings for added strength and protection from blade deflection.

The 2814 is available with either a Ball or Perma-Level Hitch, 540 or 1000 RPM CV input drivelines, Dual or Walking Tandem Axles, and 6 Selections of tires.



Find more product features and options at **BUSHHOG**.com

2820 FLEX-WING ROTARY CUTTER



HP REQUIRED
90 HP



CUTTING CAPACITY
3" DIAM



HITCH TYPE
PERMA-LEVEL
OR BALL HITCH



10
YEAR
GEARBOX LIMITED
WARRANTY



GET SPECIFICATIONS
AND ADDITIONAL
PRODUCT FEATURES

Heavy-Duty Wide-Area Cutter

The 2820 Flex-Wing meets the “more value for your investment” Bush Hog® tradition! The oil sight gauges, EZ lube drivelines, and wear bushings at axle pivots are just a few of the extra value features that separate it from competitor units. Adding maximized performance and durability that is needed for the cutting of road sides, row crops, and pastures results in a 20' Flex-Wing that is easy to distinguish from the pack. Your investment decision is easily made.

The 2820 comes standard with Deck Rings and choice of Ball or Perma-Level Hitch, 540 or 1,000 RPM CV Input Drivelines, Center Dual or Walking Tandem Axles, Wing Single, Dual, or Walking Tandem Axles, and 6 Selections of Tires.

FEATURES



Industry first, massive 3" output shaft with up to 27% more splines than smaller shafts for maximum transmission of torque to blade pan.



Bush Hog®'s EZ-Lube drivelines are quick and easy to service. All grease fittings on the PTO CV drivelines and wing drivelines closely align for quick location of grease points.



The Patented oil sight gauge takes the guess work out of checking the oil. In less than 10 seconds, all three cutting box oil levels can be checked and rechecked as often as you walk around the machine. Never climb onto the cutter again to check the gearbox oil levels.



4110 FLEX-WING ROTARY CUTTER



HP REQUIRED
60 HP



CUTTING CAPACITY
4" DIAM.



HITCH TYPE
**PERMA-LEVEL+
OR BALL HITCH**

10
YEAR
GEARBOX LIMITED
WARRANTY



**GET SPECIFICATIONS
AND ADDITIONAL
PRODUCT FEATURES**

Heavy-Duty Flex-Wing

The New 4110 Single Flex-Wing is built for the harshest roadside cutting conditions, where regulations may limit cutters blocking roadways. Designed to cut heavy grasses and brush up to 4" in diameter, these New 10' Flex-Wings are serious machines for serious users. These new cutters get the job done in any environment, day in and day out. New performance and convenience features like seriously upgraded axles, EZ blade changes with hardened hex-head bolts and bushings, and EZ-adjust leveling rods make your life easier and worry-free. Our new and improved axles glide over obstacles, while reducing shock loads for an improvement you can see and feel in the tractor seat. Heavily-braced, 7ga smooth-top decks shed debris and water for easier cleanup. Gearbox stand plates are thicker and gusseted for improved strength and durability. Our Perma-Level+ Hitch has received additional reinforcements and quality of life features like rollover and clevis stops for easier tractor hookups. Standard equipment includes convenience features like EZ-lube drivelines, increased tongue transport height, and hydraulic hose handles to reduce slipping and improve ergonomics; then when not in use, the hoses can be safely stored in the holder on the tongue.

FEATURES



Hardened hex-head blade bolts and bushings make for quick and easy blade changes



New sleek and solid weight box provides the proper weight for improved balance with less noise



Bespoke rubber isolator bank on the center axle absorbs damaging shock loads before going through the deck and eventually to the tractor



Custom-tuned suspension system reduces axle shock loads by 51%



Find more product features and options at **BUSHHOG®.com**

4115 FLEX-WING ROTARY CUTTER



HP REQUIRED
60 HP



CUTTING CAPACITY
4" DIAM.



HITCH TYPE
PERMA-LEVEL+
OR BALL HITCH

10
YEAR
GEARBOX LIMITED
WARRANTY



GET SPECIFICATIONS
AND ADDITIONAL
PRODUCT FEATURES

Heavy-Duty Flex-Wing

Building upon the success of our legendary Heavy-Duty Flex-Wing lineup, the New 4115 Flex-Wing is built for the harshest cutting conditions. Designed to cut heavy grasses and brush up to 4" in diameter, these New 15' Flex-Wings are serious machines for serious users. Perfectly at home maintaining rights-of-way and roadsides or long days clipping the back 400, these cutters get the job done in any environment, day in and day out. New performance and convenience features like seriously upgraded axles, EZ blade changes with hardened hex-head bolts and bushings, and EZ-adjust leveling rods make your life easier and worry-free. Our new and improved axles glide over obstacles, while significantly reducing shock loads for an improvement you can see and feel in the tractor seat. Heavily-braced, 7ga smooth-top decks shed debris and water for easier cleanup. Gearbox stand plates are thicker and gusseted for improved strength and durability. Our Perma-Level+ Hitch has received additional reinforcements and quality of life features like rollover and clevis stops for easier tractor hookups. Standard equipment includes convenience features like EZ-lube drivelines, increased tongue transport height, and hydraulic hose handles to reduce slipping and improve ergonomics. Then when not in use, the hoses can be safely stored in the holder on the tongue.

FEATURES



Bespoke rubber isolator bank on the center axle absorbs damaging shock loads before going through the deck and eventually to the tractor



Custom-tuned suspension system reduces axle shock loads by 51%



Hardened hex-head blade bolts and bushings make for quick and easy blade changes



Sideband integrity is protected by durable and replaceable 1/2" thick cast skids along with a 41% longer front to back formed skids



5110 FLEX-WING ROTARY CUTTER



HP REQUIRED
70 HP



CUTTING CAPACITY
5" DIAM.



HITCH TYPE
PERMA-LEVEL+
OR BALL HITCH



10
YEAR
GEARBOX LIMITED
WARRANTY



GET SPECIFICATIONS
AND ADDITIONAL
PRODUCT FEATURES

New Extreme-Duty Right-Of-Way Single Flex-Wing

Designed to cut heavy grasses and brush up to 5" in diameter, these New 10' Flex-Wings are serious machines for serious users. These cutters are perfectly at home maintaining right-of-ways, levees, and roadsides in any environment, day in and day out. New performance and convenience features like seriously upgraded axles, EZ-change blade bolts, 3/4" blade carriers with 5" blades, and EZ-adjust leveling rods make your life easier and worry-free. Our new and improved axles glide over obstacles, while reducing shock loads for an improvement you can see and feel in the tractor seat. Heavily-braced, 1/4" smooth-top decks shed debris and water for easier cleanup. Gearbox stand plates are thicker, reinforced and gusseted for improved strength and durability. Our Perma-Level+ Hitch has received additional reinforcements and quality of life features like rollover and clevis stops for easier tractor hookups. Standard equipment includes convenience features like EZ-lube drivelines, increased tongue transport height, and hydraulic hose handles to reduce hand slipping and improve ergonomics; then when not in use, the hoses can be safely stored in the holder on the tongue.

FEATURES



Reinforced axle tubes with custom rubber isolator bank on the center axle absorbs damaging shock loads before going through the deck and eventually to the tractor



3/4" uplift blade carrier is equipped with 5" blades and hardened hex-head blade bolts and bushings that make blade changes quick and easy



Custom-tuned rubber isolator pads absorb shock at each axle



1/4" x 13" sidebands are protected by 1/2" replaceable cast skids and extended front to back built-in skids



Find more product features and options at **BUSHHOG®.com**

5115 FLEX-WING ROTARY CUTTER



HP REQUIRED
70 HP



CUTTING CAPACITY
5" DIAM.



HITCH TYPE
PERMA-LEVEL+
OR BALL HITCH

10
YEAR
GEARBOX LIMITED
WARRANTY



GET SPECIFICATIONS
AND ADDITIONAL
PRODUCT FEATURES

New Extreme-Duty 15' Flex-Wing

Designed to cut heavy grasses and brush up to 5" in diameter, these New 15' Flex-Wings are serious machines for serious users. Perfectly at home maintaining rights-of-way and roadsides or long days clipping the back "400", these cutters get the job done in any environment, day in and day out. New performance and convenience features like seriously upgraded axles, EZ-change blade bolts, 3/4" Uplift Blade Carriers, and EZ-adjust leveling rods make your life easier and worry-free. Our new and improved axles glide over obstacles, while significantly reducing shock loads for an improvement you can see and feel in the tractor seat. Heavily-braced, 1/4" smooth-top decks shed debris and water for easier cleanup. Extreme-Duty gearbox stands are thicker, braced and gusseted to withstand the harshest cutting environments. Our Perma-Level+ Hitch has received additional reinforcements and quality of life features like rollover and clevis stops for easier tractor hookups. Standard equipment includes convenience features like EZ-lube drivelines, increased tongue transport height, and hydraulic hose handles to reduce hand-slipping and improve ergonomics. Then when not in use, the hoses can be safely stored in the holder on the tongue.

FEATURES



Reinforced axle tube with custom rubber isolator bank on the center axle absorbs damaging shock loads before going through the deck and eventually to the tractor



The New 5115 has substantial structural framework with Hex-Shaped Deck Rings to add stiffness to and protect the deck structure while distributing clippings more evenly



New Cast Walking Tandem Axle selection strolls over rough terrain with ease



Leveling the deck is made easy with our new cam adjuster





BUSH HOG® FLEX-WINGS

SPECIFICATION COMPARISON

	1812	1815	2120	3112	2215	2814	2820	4110	4115	5110	5115
CUTTING WIDTH	12'	15'	20'	12' 2"	15'	13' 6"	20'	10'	15'	10' 6"	15'
CUTTING HEIGHT	1 ½" - 14"	1 ½" - 14"	1 ½" - 14"	1 ½" - 14"	1 ½" - 14"	1 ½" - 14"	1 ½" - 14"	1 ½" - 14"	1 ½" - 14"	1 ½" - 16"	1 ½" - 16"
CUTTING CAPACITY	1 ½"	2 ½"	2"	3 ½"	3 ½"	3"	3"	4"	4"	5"	5"
APPROXIMATE WEIGHT (LB)	3,350	4,300	6,200	4,300	4,800	6,100	7,100	6,400	6,500	6,600	6,900
APPROXIMATE TONGUE WEIGHT (LB)	1,100	1,700	2,100	1,400	1,800	2,600	2,600	1,900	2,000	2,200	2,300
DECK THICKNESS, CENTER (GA)	10	10	10	10	10	11/10	11/10	7	7	1/4"	1/4"
DECK THICKNESS, WINGS (GA)	10	10	10	10	10	10	10	7	7	1/4"	1/4"
SIDEBANDS	1/4" x 11 ½"	1/4" x 12"	1/4" x 12"	1/4" x 12"	1/4" x 13 ½"	1/4" x 13 ½"	1/4" x 13 ½"	1/4" x 13 ½"	1/4" x 13 ½"	1/4" x 13 ½"	1/4" x 13 ½"
TRANSFER GEARBOX (HP)	160	160	160	160	250	250	250	250	250	250	250
CUTTING GEARBOX (HP)	65	130	130	130	210	225	225	225	225	225	225
GEARBOX WARRANTY (YRS)	10	10	10	10	10	10	10	10	10	10	10
INPUT DRIVELINES	Cat. 4	Cat. 5	Cat. 6	Cat. 6	Cat. 6	Cat. 6	Cat. 6	Cat. 6	Cat. 6	Cat. 6	Cat. 6
CUTTING DRIVELINES	Cat. 3	Cat. 4	Cat. 5	Cat. 4	Cat. 4	Cat. 5	Cat. 5	Cat. 4	Cat. 4	Cat. 5	Cat. 5
MINIMUM TRACTOR PTO HP	50	60	70	55	60	90	90	60	60	70	70
TRACTOR PTO SPEED	540	540 or 1,000	540 or 1,000	540 or 1,000	540 or 1,000	540 or 1,000	540 or 1,000	540 or 1,000	540 or 1,000	540 or 1,000	540 or 1,000
BLADES	1/2" x 3"	1/2" x 4"	1/2" x 4"	1/2" x 4"	1/2" x 4"	1/2" x 4"	1/2" x 4"	1/2" x 4"	1/2" x 4"	1/2" x 5"	1/2" x 5"
BLADE HOLDER	11ga Oval	7ga Round	7ga Round	7ga Round	7ga Round	7ga Round	7ga Round	7ga Round	7ga Round	3/4" Uplift	3/4" Uplift
APPROXIMATE BLADE TIP SPEED (FPM)	14,504	15,000	16,000	15,000	16,286	15,936	15,936	16,268	16,268	16,268	16,268
DEFLECTOR TYPE	Single or Double Chains	Single or Double Chains	Single or Double Chains	Single or Double Chains	Single or Double Chains	Double Chains	Single or Double Chains	Double Chains	Single or Double Chains	Double Chains	Double Chains
TIRES	Laminated, Pneumatic, Foam-Filled	Laminated, Pneumatic, Foam-Filled	Laminated, Pneumatic, Foam-Filled	Laminated, Pneumatic, Foam-Filled	Laminated, Pneumatic, Foam-Filled	Laminated, Pneumatic, Foam-Filled	Laminated, Pneumatic, Foam-Filled	Laminated, Pneumatic, Foam-Filled	Laminated, Pneumatic, Foam-Filled	Laminated, Pneumatic, Foam-Filled	Laminated, Pneumatic, Foam-Filled

Specifications and design subject to change without notice.



Find more product specifications, features and options at [BUSHHOG.com](https://www.bushhog.com)

SERIES: **BRC**



CROP FLAIL SHREDDERS

CROP FLAIL SHREDDERS



BRC SERIES CROP FLAIL SHREDDERS

MODELS: **BRC115** | **BRC118** | **BRC120** | **BRC125**



GET SPECIFICATIONS
AND ADDITIONAL
PRODUCT FEATURES

Four Models in 15', 18', 20', and 25' Widths

The Bush Hog® line of BRC row crop flails provides superior shredding performance in a number of crop conditions. Cotton, BT corn stalks, milo, rice, wheat, and vegetable stubble are no match for these machines. Designed to handle higher volumes of crop residue, the BRC models from Bush Hog® are equipped with a re-cutter bar design which allows the material to be cut three times, thereby speeding up crop decomposition. Computer-balanced 10 3/4" diameter rotors ensure smooth operation in tough conditions. Triple-lipped, sealed double row spherical roller bearings, combined with reversible, hard surfaced cutter knives and 3/16" internal steel liners at critical wear areas, ensure greater reliability in tough conditions. Bush Hog® units are available in 15', 18', 20', and 25' operating widths to match various crop conditions and row spacings. Depending on the model, the BRC row crop flails are available with pull, lift, or semi-mount hitches. These BRC row crop flails are ready to shred!

FEATURES



- Blades chops through cotton, BT corn stalks, milo, rice, wheat, or vegetable stubble.
- Re-cutter bar speeds up decomposition of plant residue to get nutrients back into the ground quickly.
- Frame provides ground cover to minimize wind and water erosion.
- Sizes available in 15-, 18-, 20-, and 25-foot widths to fit your crop's row spacing.





BUSH HOG® CROP FLAILS

SPECIFICATION COMPARISON

	BRC115	BRC118	BRC120	BRC125
CUTTING WIDTH	15'	18'	20'	25'
OVERALL WIDTH	17'	20'	22'	27'
CUTTING HEIGHT	1" to 18"	1" to 18"	1" to 18"	1" to 18"
HITCH TYPES	Category 2 – 3 QH Lift, Semi-Mount, or Pull Type	Category 2 – 3 QH Lift, Semi-Mount, or Pull Type	Category 2 – 3 QH Lift, Semi-Mount, or Pull Type	Lift, Semi-Mount, or Pull Type
CUTTER SHAFT DIAMETER	10 3/4"	10 3/4"	10 3/4"	10 3/4"
MIN. PTO HP REQUIRED	LIFT	120 HP	130 HP	130 HP
	SEMI-MOUNT	100 HP	110 HP	120 HP
	PULL-TYPE	100 HP	110 HP	120 HP
GEARBOX RATING	207 HP	207 HP	207 HP	207 HP
PTO TYPE	1,000 RPM	1,000 RPM	1,000 RPM	1,000 RPM
BLADES	Hard Surfaced: No "D" Rings	Hard Surfaced: No "D" Rings	Hard Surfaced: No "D" Rings	Hard Surfaced: No "D" Rings
BLADE TIP SPEED (FPM)	12,620	12,620	12,620	12,000
NO. OF BLADES	168	200	216	272
DRIVELINE SIZE	Category 5 or 6	Category 5 or 6	Category 5 or 6	Category 5 or 6
DRIVELINE PROTECTION	5 x5V Banded Belt	5 x5V Banded Belt	5 x5V Banded Belt	5 x5V Banded Belt
ROTOR BEARING PROTECTION	Anti-Wrap Seal Protector	Anti-Wrap Seal Protector	Anti-Wrap Seal Protector	Anti-Wrap Seal Protector
CUTTER SHAFT BEARINGS	2 3/16" Double Row Spherical Roller, Triple Sealed	2 3/16" Double Row Spherical Roller, Triple Sealed	2 3/16" Double Row Spherical Roller, Triple Sealed	2 3/16" Double Row Spherical Roller, Triple Sealed
HOOD THICKNESS	3/16" with 3/16" Internal Wear Liner	3/16" with 3/16" Internal Wear Liner	3/16" with 3/16" Internal Wear Liner	3/16" with 3/16" Internal Wear Liner
END PLATE THICKNESS	1/4"	1/4"	1/4"	1/4"
NUMBER OF AXLES	4	4	4	4
WHEEL HUB SIZE	5 bolt	5 bolt	6 bolt	6 bolt
TIRE SIZE/TYPE	6.70-5 Ribbed	6.70-5 Ribbed	9.5L-15 Ribbed	9.5L-15 Ribbed
SAFETY LIGHTS	Standard	Standard	Standard	Standard
WEIGHT (APPROXIMATE)	4,600 lb.	4,960 lb.	5,150 lb.	6,300 lb.

Specifications and design subject to change without notice.



Find more product specifications, features and options at **BUSHHOG.com**

This page intentionally left blank.

SERIES: PT5 | RMB



REAR-MOUNTED BOOM MOWERS



BOOM MOWERS

PT5 & RMB SERIES

REAR-MOUNTED BOOM MOWERS

MODELS: **PT5-2** | **RMB1445-1** | **RMB1660-1** | **RMB1865-1**



**GET SPECIFICATIONS
AND ADDITIONAL
PRODUCT FEATURES**

Extend your reach and productivity!

The ultimate in versatility, Bush Hog®'s rugged rear-mounted boom mowers are designed to trim trees, brush, or hedges and mow behind guardrails, over fences, down embankments, and around ponds. With four models reaching from 12' - 18' from the tractor centerline, there's almost no limit to what you can accomplish. They're easy to operate and built to provide years of dependable service. Two models reaching 18' - 20', offer forward reach capability, allowing the operator to bring the arm and mower head from behind the rear tire to alongside the tractor cab for improved visibility and mowing efficiency.

All RMB models offer self-contained, fully independent hydraulic systems with twin pumps for optimum cutting performance.

The PT5 is powered by the tractor's hydraulic system requiring only 3.7 gal/min flow to operate the unit.

FEATURES



Flail head attachment for RMB series 1 - 2" cutting capacity 39 - 47" cutting width



Rotary head attachment for RMB series 4" cutting capacity 60" cutting width



Cutter bar attachment for RMB series 1-1/4" cutting capacity 59" cutting width



Maximum horizontal reach (A) from 11' 5" to 18' 1"; Maximum vertical Reach (D) from 10' 2" to 22' 4"



Powertrim PT5:
3/4" cutting capacity
59" cutting width



RMB SERIES FORWARD-REACH REAR-MOUNTED BOOM MOWERS

MODELS: **RMB1880F** | **RMB2080F**



GET SPECIFICATIONS
AND ADDITIONAL
PRODUCT FEATURES

2 Models Offering 18' or 20' Reach

The forward-reach RMB mower series from Bush Hog® is available in two models ideal for more demanding agricultural, roadside maintenance and municipality use. Built to last from high grade DOMEX steel, both models pack a powerful combination of cutting capacity and reach into a rear mounted boom mower designed to handle extensive hedge cutting and verge-mowing duties. With variable forward reach capabilities, the operator can now maneuver the mower head from behind the tractor wheel to alongside the cab for improved visibility, functionality and efficiency. For use with tractors equipped with cabs, weighing a minimum of 9,920 lb. and 80 HP.

Four cutter head options are available for the forward-reach mowers. Three flail head options with a 1" - 1 ½" cutting capacity. Each come standard with adjustable front guard and flap kits to protect from thrown objects, as well as a built-in wire trap feature to help keep loose wires from becoming entangled in the rotor. The optional rotary cutter head unit offers powerful 4" cutting capacity in a 47" working width.

FEATURES



Both RMB1880F and RMB2080F models come equipped with the Evolution Control system, a more user friendly and intuitive setup operators will appreciate.

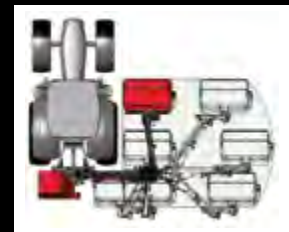

Forward Reach capability makes it possible to bring the cutter head from behind the tractor wheel up alongside the cab for greater visibility and ease of use.



An RMB mower allows the operator to reach from 18' to 20" with either a flail or rotary cutter head attachment.



Extended reach also means being able to mow down banks, around, and over obstacles like guard rails or fences thanks to the versatility of a boom mower.



Find more product features and options at **BUSHHOG®.com**



BUSH HOG® BOOM MOWERS

SPECIFICATION COMPARISON

	PT5 Powertrim-2	RMB1445-1	RMB1660-1	RMB1865-1	RMB1880F	RMB2080F
TRACTOR PTO	N/A	540	540	540	540	540
MACHINE WEIGHT (LB.)*	415 lb.	1,220 lb.	2,403 lb.	2,470 lb.	2,469 lb.	2,540 lb.
HYDRAULIC SYSTEM	Open Center Hyd. System (Closed Center Kit Avail.), Tractor Remote Outlet, 3.7 – 5.6 GPM, Flow Control Valve Kit Std	Totally Independent (Self-Contained Hyd. System, Pump Powered by Tractor PTO)	Totally Independent (Self-Contained Hyd. System, Pump Powered by Tractor PTO)	Totally Independent (Self-Contained Hyd. System, Pump Powered by Tractor PTO)	Totally Independent (Self-Contained Hyd. System, Pump Powered by Tractor PTO)	Totally Independent (Self-Contained Hyd. System, Pump Powered by Tractor PTO)
HYDRAULIC REMOTES REQUIRED	One Set	None Required	None Required	None Required	One Set If Using Rotary Cutter Head Only (to Power Hyd. Hood)	One Set If Using Rotary Cutter Head Only (to Power Hyd. Hood)
ATTACHMENT METHOD	Cat 1/2, 3-Point Mount	Cat 1/2, 3-Point Mount	Cat 1/2, 3-Point Mount	Cat 1/2, 3-Point Mount	Cat 2 & 3, 3-Point Mount	Cat 2 & 3, 3-Point Mount
CONTROLS	Cable-Controlled Hydraulic Remotes Standard	Cable-Controlled Quick Detach (QD) Standard	Cable-Controlled Quick Detach (QD) Standard	Cable-Controlled Quick Detach (QD)/ Electronic Controls (XTC) Standard	Evolution Controls (Joystick, Keypad Combination)	Evolution Controls (Joystick, Keypad Combination)
MAXIMUM REACH, HORIZONTAL (A)	11' 5"	14' 1"	16' 5"	18' 1"	18' 1"	19' 8"
MAXIMUM HEIGHT, HORIZONTAL (B)	7' 2"	13' 2"	14' 6"	16' 1"	16' 1"	17' 9"
MAXIMUM HEIGHT, HORIZONTAL (C)	5' 7"	13' 5"	15' 9"	17' 5"	17' 5"	18' 8"
MAXIMUM HEIGHT, VERTICAL (D)	10' 2"	13' 9"	20' 8"	22' 4"	22' 0"	23' 4"
MAXIMUM DEPTH, 45°	4' 6"	5' 4"	7' 3"	8' 2"	7' 10"	9' 2"
LIGHTBAR KIT	Standard	Standard	Standard	Standard	Standard	Standard

HEAD SELECTION

	PT5 Powertrim-2	RMB1445-1	RMB1660-1	RMB1865-1	RMB1880F	RMB2080F	
FLAIL HEAD MODELS	MINIMUM TRACTOR PTO HP/WEIGHT	N/A	45 HP / 4,410 lb.	60 HP / 6,614 lb.	85 HP / 9,920 lb.	80 HP / 9,920 lb.	
	ROTOR/KNIFE	N/A	Super Cut/Universal	Super Cut/F91 Competition or Multi-Cut Competition	Super Cut/F91 Competition or Multi-Cut Competition	Uni-Boot OR Omega Flail Depending on Head Model	Uni-Boot or Omega Flail Depending on Head Model
	TYPICAL APPLICATION	N/A	Grass, Light Brush	Hedge Cutting, Grass	Hedge Cutting, Grass	Hedge Cutting, Grass	Hedge Cutting, Grass
	CUTTING CAPACITY	N/A	1" Diameter	1½" Diameter	2" Diameter	1" – 1½" Diameter Depending on Head Model	1" – 1½" Diameter Depending on Head Model
	CUTTING WIDTH	N/A	39"	47"	47"	47" – 59" Depending on Head Model	47" – 59" Depending on Head Model
ROTARY HEAD MODELS	MINIMUM TRACTOR PTO HP/WEIGHT	N/A	N/A	85 HP / 7,614 lb.	85 HP / 9,920 lb.	80 HP / 9,920 lb.	
	TYPICAL APPLICATION	N/A	N/A	Grass/Brush	Grass/Brush	Grass / Brush	Grass / Brush
	CUTTING CAPACITY	N/A	N/A	4" Diameter	4" Diameter	4" Diameter	4" Diameter
	CUTTING WIDTH	N/A	N/A	60"	60"	47"	47"
CUTTER BAR MODELS	MINIMUM TRACTOR PTO HP/WEIGHT	15 HP / 1,212 lb.	45 HP / 4,410 lb.	60 HP / 6,614 lb.	85 HP / 9,920 lb.	N/A	
	CUTTER TYPE	Sickle Bar	Sickle Bar	Sickle Bar	Sickle Bar	N/A	N/A
	CUTTING CAPACITY	¾" Diameter	1 ¼" Diameter	1 ¼" Diameter	1 ¼" Diameter	N/A	N/A
	CUTTING WIDTH	59"	59"	59"	59"	N/A	N/A

* Machine Weight with Flail of RMB1445-1, RMB1660-1 and RMB1865-1 includes the weight of the oil. Due to freight requirements, units are shipped without oil. Specifications and design subject to change without notice.



Find more product specifications, features and options at **BUSHHOG.com**

SERIES: BCSS



SKID STEER BRUSH CUTTERS

SKID STEER BRUSH CUTTERS

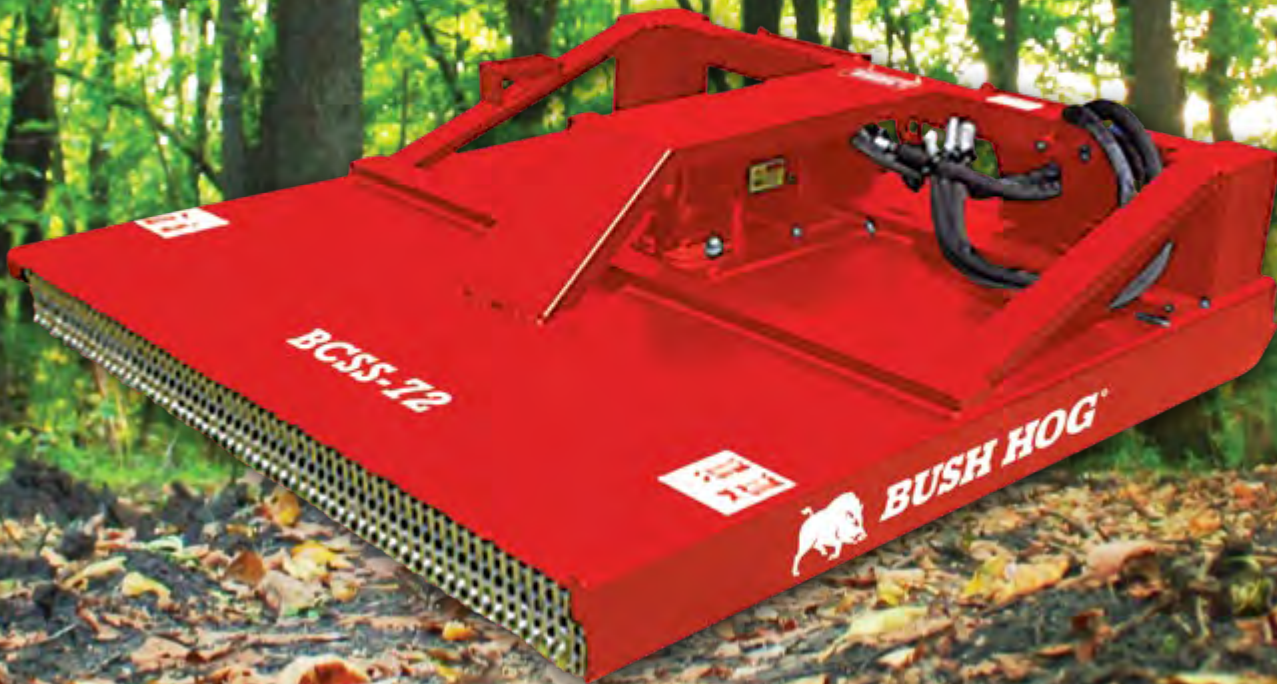

BCSS SERIES CLOSED-FRONT SKID STEER BRUSH CUTTERS

MODELS: BCSS-60LF | BCSS-60 | BCSS-72LF | BCSS-72 | BCSS-72HF | BCSS-90 | BCSS-90HF



GET SPECIFICATIONS
AND ADDITIONAL
PRODUCT FEATURES

The Bush Hog® line of BCSS skid steer brush cutters makes clearing brush and saplings easy with a selection of models designed for durability and performance. The closed front models boast heavy duty design features including solid one piece steel decks, long-lasting high tempered steel blades, balanced stump jumpers and welded collars underneath the deck to ensure years of solid performance. Complementing the heavy duty structural elements, all BCSS brush cutters incorporate optimal hydraulic motors and right angle gear boxes to achieve peak production – characterized by the highest torque available and sustained blade tip speeds proven effective in brush cutting applications. Shipped in HD wooden crates for added protection, each unit comes with hoses, couplers and gearbox guard for true “plug and play” – just pair with the appropriate carrier based on hydraulic flow (GPM) and start clearing a path.

FEATURES



BCSS-72 Single Spindle



BCSS-90 Offset Multi-Spindle



Offset Multi-Spindles and Blades

- Solid one piece ¼" steel deck
- Hydraulic motor & right-angle gearbox pairing to achieve max. torque and ideal blade tip speed
- 60" and 72" Single Spindle
- 90" Offset Multi-Spindle
- High tempered steel blades



BCSS SERIES OPEN-FRONT SKID STEER BRUSH CUTTERS

MODELS: BCSS-S601LF | BCSS-S601 | BCSS-S721LF | BCSS-S721 | BCSS-721LF | BCSS-721 | BCSS-721HF



GET SPECIFICATIONS
AND ADDITIONAL
PRODUCT FEATURES

BCSS open front models share many of the same premium design features including solid one piece steel decks, high tempered steel blades, balanced stump jumpers and welded collars underneath the deck. The single spindle standard design offers cutting widths of 60" and 72" with cutting capacity of 3" - 4". Available in 72" cutting width, the HD single spindle design with push bar feature offers a cutting capacity of 3" - 5". Select your preferred design and pair with the appropriate carrier based on hydraulic flow (GPM).

FEATURES



BCSS-S721 Standard
Single Spindle



BCSS-721 HD
Single Spindle

- Solid one piece $\frac{1}{4}$ " steel deck
- Hydraulic motor & right-angle gearbox pairing to achieve max. torque and ideal blade tip speed
- 60" and 72" Single Spindle
- Standard design in low and standard GPM flows
- HD design featuring push bar in low, standard, and high GPM flows
- High tempered steel blades
- Balanced stump jumper
- Welded collar to protect gearbox



Find more product features and options at [BUSHHOG®.com](https://www.bushhog.com)



BUSH HOG® BRUSH CUTTERS

SPECIFICATION COMPARISON

CLOSED-FRONT BRUSH CUTTERS							
	BCSS-60LF	BCSS-60	BCSS-72LF	BCSS-72	BCSS-72HF	BCSS-90	BCSS-90HF
DUTY TYPE	Heavy Duty	Heavy Duty	Heavy Duty	Heavy Duty	Heavy Duty	Heavy Duty	Heavy Duty
CUTTING WIDTH	60"	60"	72"	72"	72"	90"	90"
OVERALL WIDTH	61.750"	61.750"	73.750"	73.750"	73.750"	93.250"	93.250"
OVERALL LENGTH	72.250"	72.250"	84.250"	84.250"	84.250"	78.375"	78.375"
WEIGHT	950 lb.	970 lb.	1,168 lb.	1,168 lb.	1,224 lb.	1,790 lb.	1,840 lb.
GPM FLOW	10 – 15 GPM	16 – 25 GPM	15 – 20 GPM	21 – 25 GPM	26 – 40 GPM	20 – 25 GPM	26 – 40 GPM
CUTTING CAPACITY	3"	4"	3"	4"	5"	4"	5"
OPERATING PSI CONT./INT.	3,000 / 3,500 PSI	3,000 / 3,500 PSI	3,000 / 3,500 PSI	3,000 / 3,500 PSI	3,000 / 4,100 PSI	3,000 / 3,500 PSI	3,000 / 4,100 PSI
SPINDLE CONFIGURATION	Single-Spindle	Single-Spindle	Single-Spindle	Single-Spindle	Single-Spindle	Offset Multi-Spindle	Offset Multi-Spindle
BLADES	(2) .500" x 4.0" High Strength Updraft	(2) .500" x 4.0" High Strength Updraft	(2) .500" x 4.0" High Strength Updraft	(2) .500" x 4.0" High Strength Updraft	(2) .500" x 4.0" High Strength Updraft	(4) .500" x 4.0" High Strength Updraft	(4) .500" x 4.0" High Strength Updraft
BLADE ROTATION	Counter Clockwise	Counter Clockwise	Counter Clockwise	Counter Clockwise	Counter Clockwise	Counter Clockwise	Counter Clockwise
DECK THICKNESS	1/4" Steel	1/4" Steel	1/4" Steel	1/4" Steel	1/4" Steel	1/4" Steel	1/4" Steel
MOTOR PROTECTION	Pressure Reliefs	Pressure Reliefs	Pressure Reliefs	Pressure Reliefs	Pressure Reliefs	Pressure Reliefs	Pressure Reliefs
DRIVE PROTECTION	GRD-2 Bolt (Shear Bolt)	GRD-2 Bolt (Shear Bolt)	GRD-2 Bolt (Shear Bolt)	GRD-2 Bolt (Shear Bolt)	GRD-2 Bolt (Shear Bolt)	GRD-2 Bolt (Shear Bolt)	GRD-2 Bolt (Shear Bolt)
MOTOR/GEARBOX COUPLER	Machined Steel	Machined Steel	Machined Steel	Machined Steel	Machined Steel	Machined Steel	Machined Steel

OPEN-FRONT BRUSH CUTTERS							
	BCSS-S601LF	BCSS-S601	BCSS-S721LF	BCSS-S721	BCSS-721LF	BCSS-721	BCSS-721HF
DUTY TYPE	Standard Duty	Standard Duty	Standard Duty	Standard Duty	Heavy Duty	Heavy Duty	Heavy Duty
CUTTING WIDTH	60"	60"	72"	72"	72"	72"	72"
OVERALL WIDTH	61.750"	61.750"	73.750"	73.750"	73.750"	73.750"	73.750"
OVERALL LENGTH	72.250"	72.250"	84.250"	84.250"	84.250"	84.250"	84.250"
WEIGHT	840 lb.	840 lb.	1,000 lb.	1,000 lb.	1,186 lb.	1,220 lb.	1,270 lb.
GPM FLOW	10 – 15 GPM	16 – 25 GPM	15 – 20 GPM	21 – 25 GPM	15 – 20 GPM	21 – 25 GPM	26 – 40 GPM
CUTTING CAPACITY	3"	4"	3"	4"	3"	4"	5"
OPERATING PSI CONT./INT.	3,000 / 3,500 PSI	3,000 / 3,500 PSI	3,000 / 3,500 PSI	3,000 / 3,500 PSI	3,000 / 3,500 PSI	3,000 / 3,500 PSI	3,000 / 3,500 PSI
SPINDLE CONFIGURATION	Single-Spindle	Single-Spindle	Single-Spindle	Single-Spindle	Single-Spindle	Single-Spindle	Single-Spindle
BLADES	(2) .500" x 4.0" High Strength	(2) .500" x 4.0" High Strength	(2) .500" x 4.0" High Strength	(2) .500" x 4.0" High Strength	(2) .500" x 4.0" High Strength	(2) .500" x 4.0" High Strength	(2) .500" x 4.0" High Strength
BLADE ROTATION	Counter Clockwise	Counter Clockwise	Counter Clockwise	Counter Clockwise	Counter Clockwise	Counter Clockwise	Counter Clockwise
DECK THICKNESS	1/4" Steel	1/4" Steel	1/4" Steel	1/4" Steel	1/4" Steel	1/4" Steel	1/4" Steel
MOTOR PROTECTION	Pressure Reliefs	Pressure Reliefs	Pressure Reliefs	Pressure Reliefs	Pressure Reliefs	Pressure Reliefs	Pressure Reliefs
DRIVE PROTECTION	GRD-2 Bolt (Shear Bolt)	GRD-2 Bolt (Shear Bolt)	GRD-2 Bolt (Shear Bolt)	GRD-2 Bolt (Shear Bolt)	GRD-2 Bolt (Shear Bolt)	GRD-2 Bolt (Shear Bolt)	GRD-2 Bolt (Shear Bolt)
MOTOR/GEARBOX COUPLER	Machined Steel	Machined Steel	Machined Steel	Machined Steel	Machined Steel	Machined Steel	Machined Steel

Specifications and design subject to change without notice.



Find more product specifications, features and options at [BUSHHOG.com](https://www.bushhog.com)

PULL DIRT SCRAPERS | POST HOLE DIGGERS | BACKHOES | GRAPPLES | PALLET FORKS | BUCKETS



CONSTRUCTION IMPLEMENTS



CONSTRUCTION IMPLEMENTS

DSP SERIES

PULL DIRT SCRAPERS

MODELS: **DSP8** | **DSP10** | **DSP12**



GET SPECIFICATIONS
AND ADDITIONAL
PRODUCT FEATURES

Bush Hog®'s DSP Line of pull-type drag scrapers, with standard fixed axle or optional tilt axle, is ideal for moving large quantities of material, for leveling, and for finish grading. DSP units come available in 8', 10' and 12' widths. DSP scrapers equipped with the optional tilt axle can do everything models equipped with standard axles can, as well as remove material on an angle for sloping, terracing and ditching. Material can be transferred by dragging to nearby locations and raising the scraper to deposit the load. Surfaces can be graded and leveled by scraping material from high areas and allowing accumulated material to flow under the grader blade into lower areas. DSP scrapers are designed for 70 – 125 HP tractors and have replaceable wear plates on the sides.

FEATURES



- Available in 8', 10', and 12' widths
- Optional tilt axle removes material on an angle for sloping, terracing and ditching.
- DSP scrapers are designed for 70 to 125 horsepower tractors
- Replaceable wear plates on the sides.
- Reversible and replaceable cutting edge



PHD SERIES

POST HOLE DIGGERS

MODELS: PHD2401 | PHD2402 | PHD2403



GET SPECIFICATIONS
AND ADDITIONAL
PRODUCT FEATURES

FEATURES



Whether you need to drill holes for posts, tree plantings, structural support members, or other tasks, Bush Hog® has a post hole digger to meet your needs. Our three 2400 Series models fit both Category 1 and Category 2 tractors. Drivelines are protected by shear bolt. Augers are offered in both standard and heavy duty versions in sizes from 6" - 24" depending on digger model. Tough soil penetration is no problem for powerful Bush Hog® post hole diggers.



- Bush Hog® offers both regular duty and heavy duty augers in a variety of sizes, from 6" - 24" depending on the model
- 2" Round hub connection
- Replaceable drill teeth
- Heavy duty augers are equipped with double flighting for added cutting surface, resulting in faster, easier digging - especially in heavier soils
- Rugged gearbox construction
- Special alloy pinion gears and tapered roller bearings on both sides of each gear



Find more product features and options at [BUSHHOG®.com](https://www.bushhog.com)

PHDH SERIES HYDRAULIC POST HOLE DIGGERS

MODELS: PHDHF15-2 | PHDHF20-2 | PHDHF30-2 | PHDHF35 | PHDHC20 | PHDHC30 | PHDHC35



GET SPECIFICATIONS AND ADDITIONAL PRODUCT FEATURES

FEATURES

CLICK A MODEL IMAGE BELOW FOR ADDITIONAL INFORMATION

Planetary Hydraulic drive features a high torque level to power the auger through the most demanding conditions.

All augers are heavy industrial grade with 3/8" thick flighting. Sized in diameters from 6"-36" (depending on model), these are excellent for all soil conditions and solid rock.

The Farm and Ranch PHDHF Series features a selection of mounting brackets for skid steer loaders and front end loaders.

The Commercial Grade PHDHC Series features mounting brackets for excavators, skid steer loaders, backhoes and front end loaders.

All mounting brackets have a dual swivel feature that keeps the auger vertical while digging.



PHDHF FARM/RANCH SERIES



PHDHC CONSTRUCTION/ CONTRACTOR SERIES

AVAILABLE AUGER TYPES

Note: Auger tips are available only in black. Shown in yellow for visual effect only.



HRAD*



HSRA*



HSDA**



T-POST**

* Available only for C-Series posthole diggers

** Available for both C & F-Series posthole diggers



XD SERIES BACKHOES

MODELS: **XD65C** | **XD65** | **XD75** | **XD95** | **XD95EL**



GET SPECIFICATIONS
AND ADDITIONAL
PRODUCT FEATURES

Break ground, not your back!

Easily access those tight work spaces and get down to some digging. Bush Hog®'s line of XD series backhoes are designed for tractors ranging from 18 - 100 HP along with skid steers and mini skid steers depending on the model. Perfect for digging footers, trenches and all general landscaping and construction needs, XD series backhoes deliver value and strong performance to your operation.

FEATURES

CLICK A MODEL IMAGE BELOW FOR ADDITIONAL INFORMATION

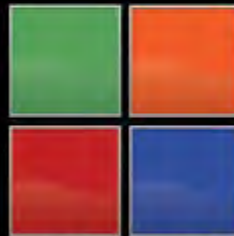

PICK A COLOR
TO MATCH
YOUR TRACTOR



XD65C

For Tractors 18-28 HP
& Mini Skidsteer



XD65

For Subcompact Tractors
18 - 30 HP



XD75

For Midsize Tractors
30 - 60 HP



XD95

For Tractors 30 - 100 HP



XD95EL

For Midsize Tractors
30 - 60 HP



Find more product features and options at **BUSHHOG®.com**

AGR, BGR, & BRGR SERIES GRAPPLES

MODELS: **AGR60** | **AGR72** | **BGR72T** | **BGR84T** | **BGR72** | **BGR84** | **BRGR72** | **BRGR84**

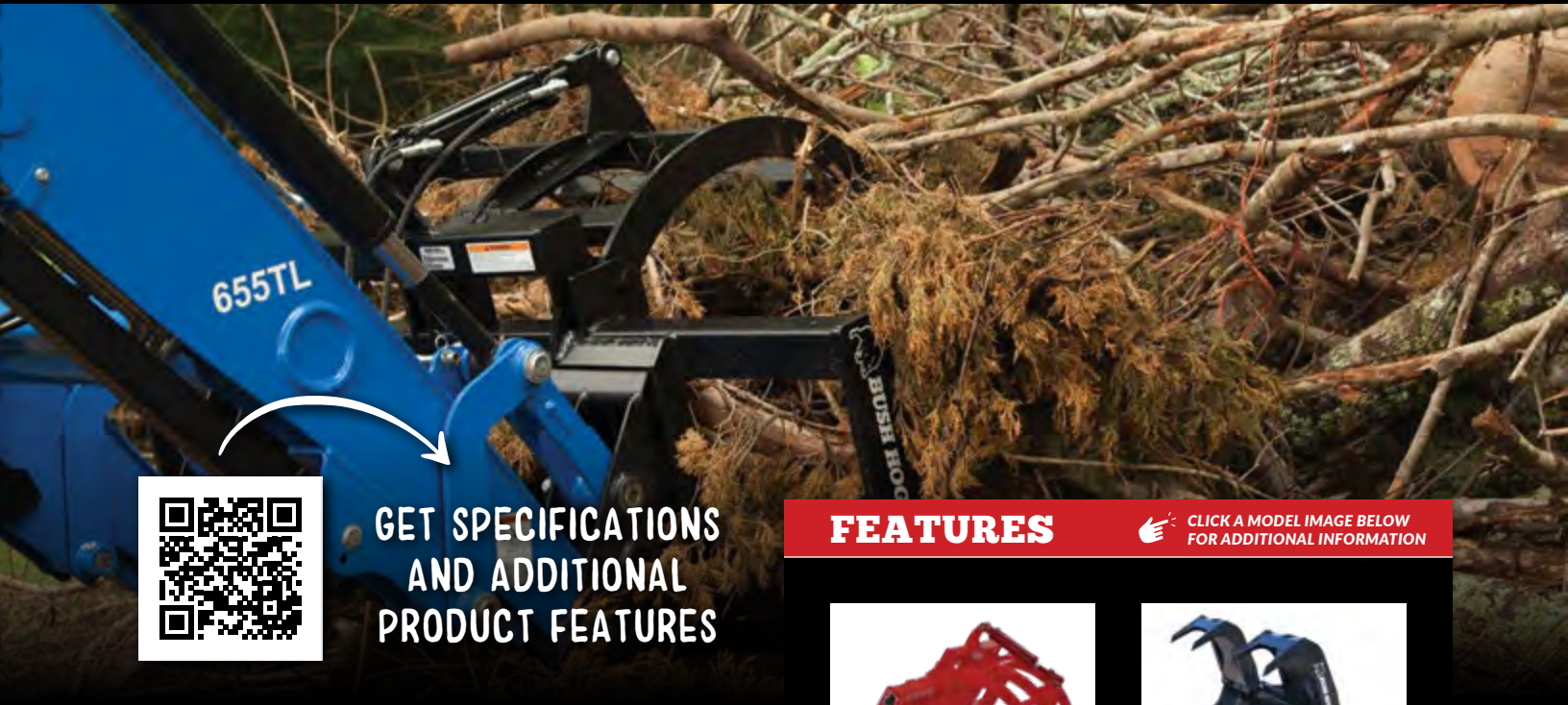

GET SPECIFICATIONS AND ADDITIONAL PRODUCT FEATURES

Bush Hog®'s AG, BGR, and BRGR series grapples are built tough and help you make quick work of larger jobs. The AG and BGR grapples use an open bottom design to move brush and debris, rake, and dig without picking up dirt. The BRGR-series provides the operator with the grasp and hold abilities of a grapple, along with the storage capacity of a conventional bucket. Each model is designed to mount onto a universal skid steer mount. Let Bush Hog®'s grapples help you get a grip on your work.

FEATURES

CLICK A MODEL IMAGE BELOW FOR ADDITIONAL INFORMATION



AG SERIES GRAPPLES

Open-bottom design to move brush and debris, rake, and dig without picking up dirt. Designed to mount onto a universal skid steer mount.



BGR SERIES GRAPPLES

Open-bottom design to move brush and debris, rake, and dig without picking up dirt. Designed to mount onto a universal skid steer mount.



BRGR SERIES GRAPPLES

Provide the operator with the grasp and hold abilities of a grapple, along with the storage capacity of a conventional bucket. Designed to mount onto a universal skid steer mount.



PFD SERIES

PALLET FORKS

MODELS: PFLD | PFHD | PFXHD



GET SPECIFICATIONS
AND ADDITIONAL
PRODUCT FEATURES

The PFD series pallet forks can be used in a variety of applications, from around the farm to nurseries to construction sites, the PFD series forks will save you time and money. Quickly and conveniently convert your tractor mounted or skid steer loader with a universal skid steer frame into a material handler and expand the utilization of existing machines. With a lift capacity of up to 5,500 pounds, the PFD series pallet forks will handle the lifting for you.

FEATURES



- 48" Fork length
- Up to 5,500lb capacity
- Forks adjustable in 3" increments
- Attachment methods – skid steer or tractor loader
- Models are compatible with Skid Steer, John Deere and Euro Quick Attach Systems



Find more product features and options at [BUSHHOG®.com](https://www.bushhog.com)

SSB & EB SERIES

BUCKETS

MODELS: **SSB72US** | **SSB78LL** | **SSB84US** | **EB72US** | **EB82US** | **EB82SL** | **EB94SL**

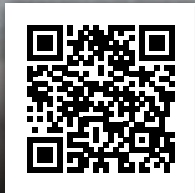

GET SPECIFICATIONS
AND ADDITIONAL
PRODUCT FEATURES

The SSB Series of loader buckets are a heavier duty option than most OEM buckets for replacement in skid steer applications. With sizes ranging from 74" up to 86" in width and a bolt on reversible durable $\frac{3}{4}$ "x8" cutting edge these buckets are up for the job. All feature powder coat paint.

The EB Series of loader buckets are a heavier duty option than most OEM buckets. With sizes ranging from 73" up to 95" in width and a Welded on durable $\frac{3}{4}$ "x6" cutting edge these buckets are up for the job. All feature powder coat paint.

FEATURES

CLICK A MODEL IMAGE BELOW FOR ADDITIONAL INFORMATION



SSB SERIES BUCKETS

- 36"/42" Overall Depth
- $\frac{3}{4}$ "x8" Bolt-On/Reversible Cutting Edge
- 15.7 Cu/Ft 16.4 Cu/Ft 18.3 Cu/Ft Volume



EB SERIES BUCKETS

- 34.5"/37" Overall Depth
- $\frac{3}{4}$ "x6" Welded
- 18.7 Cu/Ft 21.4 Cu/Ft 29.0 Cu/Ft 34.0 Cu/Ft Volume





LANDSCAPE IMPLEMENTS



LANDSCAPE IMPLEMENTS

COMPACT IMPLEMENTS

CRB REAR BLADES | CBX BOX BLADES | CLR LANDSCAPE RAKES | CRG ROAD GRADERS | CAR AERATORS | CPG PLUGGERS | RTC TILLERS



GET SPECIFICATIONS
AND ADDITIONAL
PRODUCT FEATURES

Bush Hog®'s compact landscaping tools are designed to do big things with small tractors up to 24 HP. All implements feature Bush Hog®'s legendary rugged construction and performance features that will help you get the job done not just today or tomorrow, but for many years to come.

Whether a professional landscaper, farmer, or weekend warrior, our line of landscape tools deliver results. We offer many different models and sizes, with one just right for your operation. See your local dealer for information, and advice. When you need a quality product that will last for years, the smart choice is Bush Hog®.

COMPACT SERIES CLICK A MODEL IMAGE BELOW FOR ADDITIONAL INFORMATION



CRB REAR BLADES

- Working Widths: 4' - 6'
- Tilt Adjustment: 3-pt. Hitch
- Blade Weight: 136 lb. - 164 lb.



CBX BOX BLADES

- Working Widths: 4' - 5'
- Scarifier Teeth: 4 - 5
- Blade Weight: 248 lb. - 258 lb.



CLR LANDSCAPE RAKES

- Working Widths: 4' & 5'
- For Tractors Up to 24 HP
- Approx. Weight: 126 lb. & 143 lb.



CRG ROAD GRADERS

- Working Widths: 4' - 5'
- Maximum HP: 20 (FWA); 24 (2WD)
- Approx. Weight: 238 lb. - 297 lb.



CAR AERATORS

- Working Widths: 4' - 6'
- Designer for Compact Tractors Up to 25 HP, ATVs, and UTVs



CPG PLUGGERS

- Working Widths: 4' - 6'
- Designer for Compact Tractors Up to 25 HP, ATVs, and UTVs



RTC TILLERS

- Tilling Width: 4'
- Number of Blades: 6
- Tractor HP Range: 15 - 25 PTO



BLADES

SERIES: **CRB** | **CBX** | **BBX** | **MBX** | **RBX** | **SBX** | **RO** | **35** | **50** | **70** | **91** | **100** | **141** | **160** | **181** | **225** | **300**



GET SPECIFICATIONS
AND ADDITIONAL
PRODUCT FEATURES

We can help you out of a tough scrape!

4' to 14' Rugged Blades

If you need a tool for landscaping, snow removal, feed lot work, ditching, terracing, dam building, road reconditioning, or general farm maintenance, a Bush Hog® rear-mounted blade is always the answer. Bush Hog® offers models ranging from light duty to heavy duty in a variety of widths, all engineered and built to provide years of service under demanding conditions at a very reasonable price. So if you find yourself facing a tough scrape, turn to Bush Hog® for performance you can count on!

BLADE SERIES

CLICK A MODEL IMAGE BELOW FOR ADDITIONAL INFORMATION



CRB SERIES



CBX SERIES



BBX SERIES



MBX SERIES



RBX SERIES



SBX SERIES



RO SERIES



35 SERIES



50 SERIES



70 SERIES



91 SERIES



100 SERIES



141 SERIES



160 SERIES



181 SERIES



225 SERIES



300 SERIES



Find more product features and options at **BUSHHOG.com**

BHQA SERIES CATEGORY 1 & 2 QUICK HITCHES

MODELS: **BHQA1** | **BHQA2**



GET SPECIFICATIONS
AND ADDITIONAL
PRODUCT FEATURES

Bush Hog®'s Category 1 & 2 Quick Hitches make the job quick and easy!

Make your life easier with Bush Hog®'s Quick Hitches. Our Quick Hitches have an adjustable top link bracket that allows them to fit most Category 1 or Category 2 tractors and implements.

FEATURES

CLICK A MODEL IMAGE BELOW FOR ADDITIONAL INFORMATION



BHQA1

Category 1 Quick Hitch with adjustable top link bracket. Fits most Category 1 tractors and implements.



BHQA2

Category 2 Quick Hitch. Fits most Category 2 tractors and implements.



CP SERIES CULTIPACKERS

MODELS: CP960 | CP972 | CP984 | CP996 | CP1560 | CP1572 | CP1584 | CP1596 | CP1660 | CP1672 | CP1684 | CP1696



GET SPECIFICATIONS
AND ADDITIONAL
PRODUCT FEATURES

Get your soil flattened and packed with Bush Hog®'s series of Cultipackers! Our Cultipackers help you improve germination rates by lightly tamping seed under the soil to a proper depth to keep them from drying out or not getting enough sunlight. These units can be used anywhere you might sow seed. They are perfect tools for seeding food plots, overseeding a lawn, or smoothing out rough pastures or sports fields after discing or tilling.

Our strong tubular steel frames house heavy-duty wheels to compact, aerate, and smooth your soil with ease. Cover your tractor tracks with sizes ranging from 60" to 96" in working width. Choose from three different wheel options to meet your needs: the 9.5" notched gray iron wheels crush clumped soil making a smoother overall surface but leaving slight dimples to retain moisture; the 15" smooth gray iron wheels pack the soil enough to reduce erosion while leaving v-shaped grooves to help retain moisture; the 16" notched ductile iron performs the same duties as the 9.5, and in addition, it has a higher impact strength and floats better over sandy or soft soils.

FEATURES



- Strong tubular steel construction
- 3 different size and material wheel options
- Category 1 & 2 Standard, & Quick Hitch
- Stands for keeping the unit upright and the hitch off the ground when not in use



Find more product features and options at [BUSHHOG®.com](https://www.bushhog.com)

RG, HDRG, & BHCG SERIES ROAD GRADERS

MODELS: **RG60** | **RG72** | **RG84** | **HDRG84** | **HDRG96** | **BHCG84**



GET SPECIFICATIONS
AND ADDITIONAL
PRODUCT FEATURES

Potholes beware!

Bush Hog®'s line of road graders smooth out your ride and return your dirt, gravel or slag roads to like-new condition. These road graders cut off material from the high spots in your road and deposit the material in the low lying areas, thereby leveling the surface. The RG Series road graders are available in 5', 6' and 7' operating widths and are designed for use on tractors up to 50 HP. The heavy-duty road grader is available in 7' and 8' operating widths.

The **NEW** Bush Hog Crowning Grader 84" (CG84) has 13 heavy-duty scarifiers coupled with a hydraulically controlled angling blade. The CG84 makes short work of the most neglected roads. The heavy-duty shanks rip the potholes and washboard roadbeds then the remote adjustable blade moves the loose material to create a crown in the road to facilitate drainage. Available in both skid steer mounting and optional CATI/II 3pt hitch. Rated for skid steers and tractors between 45 and 100hp. Works equally well in both dirt and gravel road conditions.

FEATURES

CLICK A MODEL IMAGE BELOW FOR ADDITIONAL INFORMATION

RG SERIES ROAD GRADERS



Scarifiers can rip soil up to 2 3/8" deep



Dual, replaceable and reversible 1/2" x 6" cutting edges.

HDRG SERIES HEAVY-DUTY GRADERS



Four-position hardened steel shanks

Category 1 – 2 quick hitch compatible
All welded steel frame construction
Cutting edge height adjustment

BHCG SERIES CROWNING GRADERS



Skid steer & optional category I, II quick hitch compatible
Recommended for skid steers and tractors between 45 and 100 hp



LLR & MLR SERIES

LANDSCAPE RAKES

MODELS: **LLR60** | **LLR72** | **LLR84** | **MLR72** | **MLR84** | **MLR96**

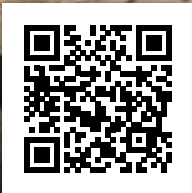

GET SPECIFICATIONS
AND ADDITIONAL
PRODUCT FEATURES

Bush Hog®'s line of landscape rakes are the perfect tools for removing debris or giving an area that "groomed look." Perfect for jobs ranging from brush removal to grooming horse arenas, this tool is available in both a light duty model for tractors up to 30 PTO HP and a medium duty model for tractors up to 50 PTO HP. One-inch spacing between the heat-treated tines allows you to easily remove sticks, small rocks and other unwanted material. An optional gauge wheel is available for both models and the medium duty model offers a ratchet or hydraulic cylinder option to control angle adjustment. All units feature 360° pivot ability with angle adjustment of the rake, and a king pin size of 1 ¼". With a Cat. 1 Std. and Quick Hitch, and in sizes from 60" - 96" widths, there is sure to be a Bush Hog® Landscape Rake to match your requirements.

FEATURES

CLICK A MODEL IMAGE BELOW FOR ADDITIONAL INFORMATION



LLR SERIES LANDSCAPE RAKES

- Working Width: 5' - 7'
- Maximum Tractor HP: 35 PTO
- Approximate Weight: 205 - 245 lb.



MLR SERIES LANDSCAPE RAKES

- Working Width: 6' - 8'
- Maximum Tractor HP: 50 PTO
- Approximate Weight: 325 - 365 lb.



Find more product features and options at **BUSHHOG®.com**

PVB & PVS SERIES PULVERIZERS

MODELS: PVB/S-600 | PVB/S-602 | PVB/S-660 | PVB/S-662 | PVB/S-720 | PVB/S-722 | PVB/S-840 | PVB/S-842

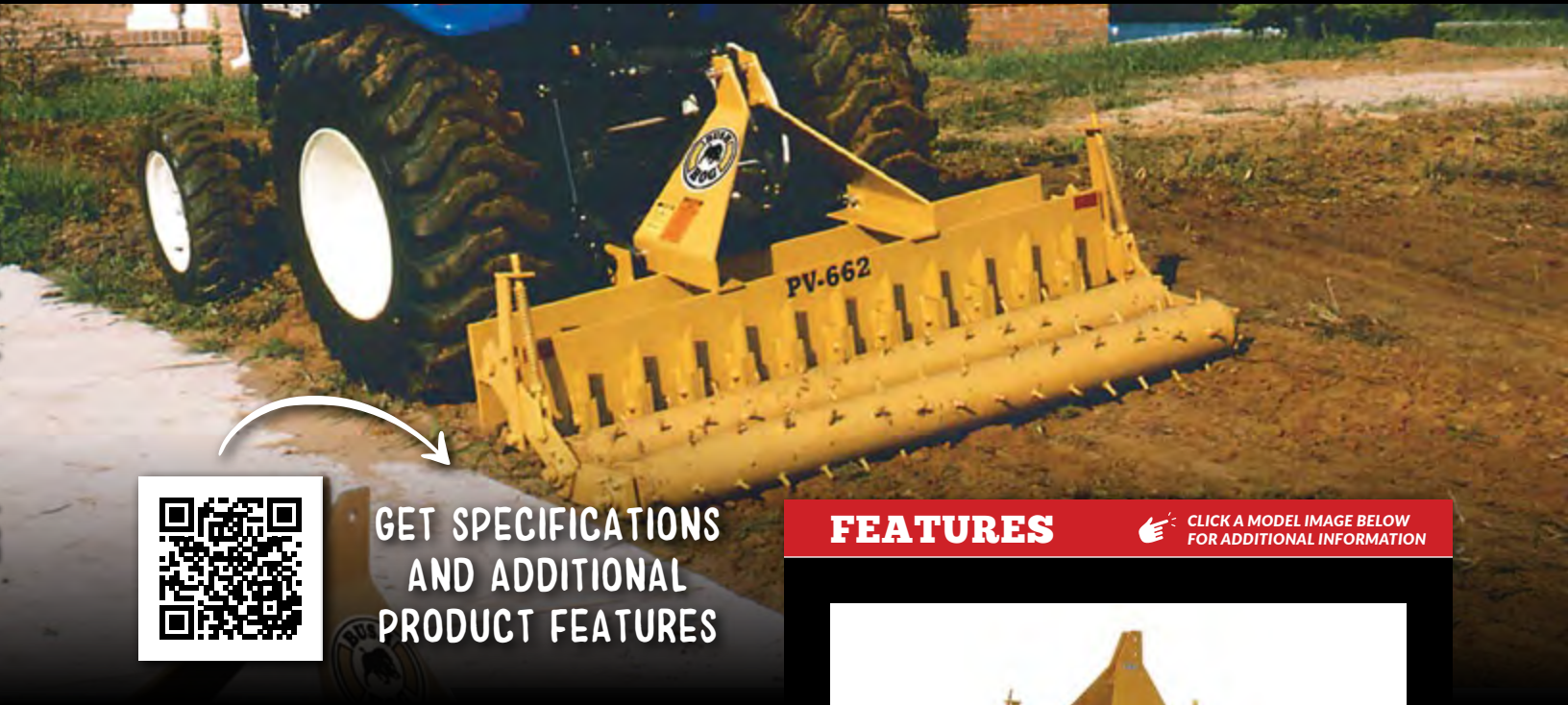

GET SPECIFICATIONS
AND ADDITIONAL
PRODUCT FEATURES

PVB Bar Shank & PVS Spike Shank Pulverizers

After the heavy material has been removed, a Bush Hog® Pulverizer becomes the perfect tool to prepare a seedbed. The steel shanks break up compacted soil, while the heavy roller pulverizes large clumps and prepares the area for seeding. This tool is ideal for the professional landscaper/contractor who requires clean, level ground in one pass. Available in 60", 72", and 84" widths, with one or two rollers and featuring a Category 1 Standard and Quick Hitch, there is sure to be a Bush Hog® Pulverizer to match your requirements.

FEATURES

CLICK A MODEL IMAGE BELOW
FOR ADDITIONAL INFORMATION



PVB/S SINGLE ROLL PULVERIZERS

- Working Width: 5' - 7'
- Maximum Tractor HP: 60 PTO
- Approximate Weight: 530 - 650 lb.



PVB/S DOUBLE ROLL PULVERIZERS

- Working Width: 5' - 7'
- Maximum Tractor HP: 60 PTO
- Approximate Weight: 530 - 650 lb.



MPG SERIES PLUGGERS

MODELS: **MPG-600** | **MPG-720**



GET SPECIFICATIONS
AND ADDITIONAL
PRODUCT FEATURES

The Bush Hog® Pluggers are literally designed to get to “the root of the problem.” The 3/4" spoons provide excellent soil penetration, allowing nutrients and air to reach the turf’s root system. A 1¼" diameter shaft with greasable sleeves supports the independent hubs. The frame is designed as a weight box so that additional weight may be added to increase down pressure when the soil is heavily compacted. All models feature a Category 1 Standard and Quick Hitch and Quick Hitch and are rated for tractors up to 60 PTO HP.

FEATURES



- Working Width: 5' – 6'
- Maximum Tractor HP: 60 PTO
- Approximate Weight: 460 – 500 lb.
- Heavy-duty weight rack
- Quick hitch compatible
- Available with closed spoons or slicing knives
- Core type aerator



You get consistent plugs up to 3/4" to promote root growth.



Find more product features and options at **BUSHHOG®.com**

FSP SERIES FERTILIZER & SEED SPREADERS

MODELS: **FSP-500** | **FSP-800**



**GET SPECIFICATIONS
AND ADDITIONAL
PRODUCT FEATURES**

FEATURES



The Bush Hog® three-point hitch fertilizer spreaders have bottom opening gates for accurate flow rates. Variable gate position openings and fine adjustments ensure material drops on different positions of the spinning disc. This produces a center, right and left pattern. The polyethylene hopper offers long lasting protection from the deteriorating effects of fertilizer. For further resistance to deterioration, the distribution fins are electroplated and the paint is powder coat for hardness and durability.

The FSP models can also be used to distribute seeds. The FSP-500 has a weight capacity of 500 lb., and the FSP-800 has a weight capacity of 800 lb.

- Bottom opening gates for accurate flow rates
- Variable gate position openings and fine adjustments
- FSP-500 has a weight capacity of 500 lb.
- FSP-800 has a weight capacity of 800 lb.
- Polyethylene hopper offers long lasting protection from the deteriorating effects of fertilizer.
- Distribution fins are electroplated and the paint is powder coat for hardness and durability.



MS SERIES MANURE SPREADERS

MODELS: MS250G | MS500G | MS800G | MS500P | MS800P | MS1300P

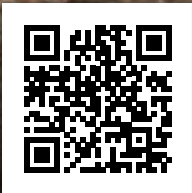
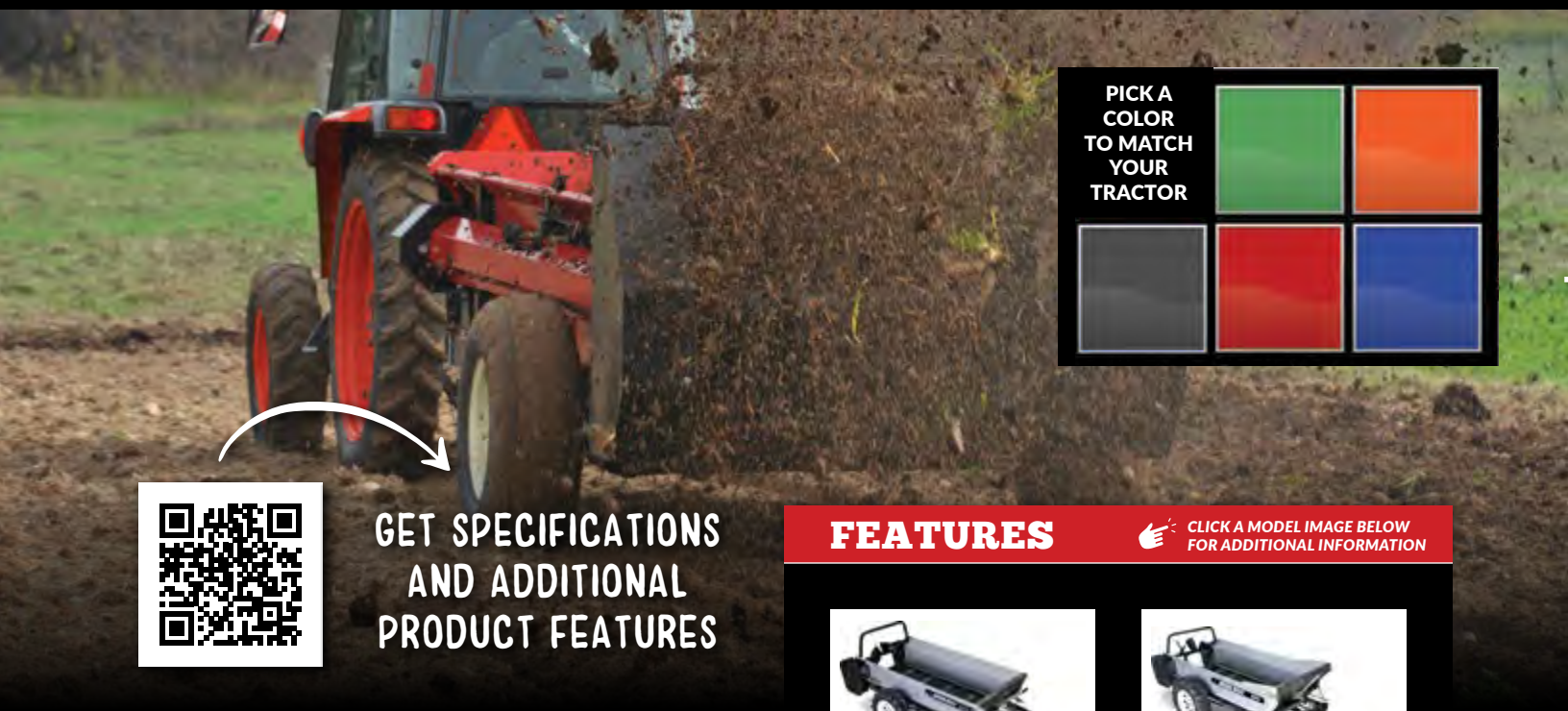

GET SPECIFICATIONS AND ADDITIONAL PRODUCT FEATURES

FEATURES

CLICK A MODEL IMAGE BELOW FOR ADDITIONAL INFORMATION



MS250G
Recommended 15-25 HP



MS500G
Recommended 15-30 HP



MS800G
Recommended 20-45 HP



MS500P
Recommended 18-30 HP



MS800P
Recommended 25-45 HP



MS1300P
Recommended 45-75 HP

MS-G Ground-Driven Manure Spreaders For Vehicles Without PTO Capabilities

MS-G Manure Spreaders offer simplicity and reliability for applications where a PTO doesn't exist. Offering a full size range, MS-G ground drive units can be used with vehicles such as ATVs, UTVs or even lawn tractors. Traction implement tires are standard on GROUND DRIVE units to ensure the torque is there for a fine, consistent spread.

MS-P PTO Driven Manure Spreaders For Vehicles with PTO Power

The PTO-driven MS-P Series manure spreaders offer increased power and spreading consistency combined with ease of use. PTO DRIVE models harness the power of your tractor to deliver capacities of 50, 80 and 130 bushels to your field. Connected by belt and pulley, the driveshaft and gear box deliver efficient power to the beaters.



Find more product features and options at **BUSHHOG®.com**

This page intentionally left blank.

TILLERS | HARROWS | PLOWS | SUBSOILERS | CULTIVATORS | PASTURE AERATORS



TILLAGE IMPLEMENTS



TILLAGE IMPLEMENTS

RTC SERIES COMPACT ROTARY TILLERS

MODELS: **RTC50G**



GET SPECIFICATIONS
AND ADDITIONAL
PRODUCT FEATURES

FEATURES



The RTC50G is ideal for tractors from 15 to 25 horsepower. Usually found on heavy-duty and more expensive tillers, the durable slip-clutch driveline and six tines per flange, forward-rotation rotor provides maximum mulching of material. The side gear drive will give years of performance without having to consider chain wear and adjustment. The rear gate can be adjusted for the desired leveling of material. Perfect for creating large food plots, vegetable and flower gardens, and green fields, the RTC50G can help you turn your property into a land of opportunity!

- Heavy-Duty Gearbox
- Slip Clutch Standard
- Adjustable Skid Shoes
- Formed Tailgate
- Double Strap Hitch
- 4-inch offset to the right and center mount
- Side Gear Drive
- Forward Rotation Rotor
- 1-year machine limited warranty with a 5-year limited warranty on the center and side gearboxes (years 3-5, parts only).



RTG SERIES

ROTARY TILLERS

MODELS: RT60G | RT60GR | RT72G | RT72GR | RT84G | RT84GR



GET SPECIFICATIONS
AND ADDITIONAL
PRODUCT FEATURES

The gear-driven RTG Series Rotary Cutters are built Bush Hog® tough for years of dependable service. Available in standard or reverse till, there is a model that will fit your application. In ground cover conditions, a reverse till model works best because the flow of material tends to cover the chopped groundcover for quicker decomposition. Six blades per flange on every model gives the maximum breakup of soil even in hard or packed conditions. The heavy-duty gear drive alleviates worries about the durability of a chain drive in the same tough conditions. The RTG Series is the perfect tool for landscape work, seed beds, or any other application that requires that the soil be pulverized.

FEATURES



- 4'11", 5'10 ½", and 7' 10 ½" tilling widths for 25 – 65 PTO HP tractors
- Units available in both forward rotation (RTG) and reverse rotation (RTGR) models
- ASAE Category 1, Standard and Quick Hitch (Category 1 and 2 Std & QH on RT84G)
- Available in Red, Green, Orange and Blue



Gears in side housing are immersed in oil to maintain lubricity and dissipate heat making the drivetrain more durable than chain drives



Find more product features and options at [BUSHHOG®.com](https://www.bushhog.com)

RTX SERIES HEAVY-DUTY ROTARY TILLERS

MODELS: **RTX85G** | **RTX92G**



GET SPECIFICATIONS
AND ADDITIONAL
PRODUCT FEATURES

Bush Hog®'s heaviest-built, gear-driven tillers for the toughest jobs and higher HP tractors. The RTX Series features a heavy-duty A-frame hitch and larger blades.

Models come with a 1-year machine limited warranty with a 5 year limited warranty on the center and side gearboxes (years 2-5, parts only). Available in forward rotation only.

FEATURES



- 7'1" and 7'8" tilling widths for 60 - 90 PTO HP tractors
- For higher HP tractors
- Gear drive
- Heavy duty A-frame hitch
- Heavy duty rotor with larger blades



Gears in side housing are immersed in oil to maintain lubricity and dissipate heat making the drivetrain more durable than chain drives



1D, 2D, & 3D SERIES LIFT DISC HARROWS

MODELS: **1D60** | **1D78** | **2D78** | **2D96** | **3D96** | **3D118**

PICK A COLOR TO MATCH YOUR TRACTOR

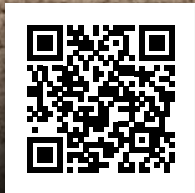

GET SPECIFICATIONS AND ADDITIONAL PRODUCT FEATURES

FEATURES

CLICK A MODEL IMAGE BELOW FOR ADDITIONAL INFORMATION

Bush Hog®'s line of lift disc harrows is designed to expand your tractor's productivity potential! Whether you are a gardener, small farmer, wildlife manager, landscaper, operate a nursery or simply someone looking to break up the ground, the heavy duty frames and the heat-treated notched disc blades of Bush Hog® lift disc harrows make them the right choice for the job. The three disc harrow series in the Bush Hog® line are designed to fit tractors from 35 to 95 horsepower, giving you several choices to properly fit your tractor and application. Easy-to-adjust front and rear gangs allow you to change from light tilling to more aggressive cutting action with a simple pull of a pin and repositioning of the gangs. Enhance the performance of your equipment with optional disc scrappers. The sky (well actually, the dirt) is the limit when using a Bush Hog® lift disc harrow to solve your groundbreaking needs.



1D SERIES

- Cutting Width: 5'8" – 6"
- No. of Disc Blades: 14



2D SERIES

- Cutting Width: 6" – 8"
- No. of Disc Blades: 18 – 20



3D SERIES

- Cutting Width: 8" – 9'10"
- No. of Disc Blades: 22 – 26



Bearing hangers reinforced with gussets



Easy-to-grasp handle for simple gang adjustment



Notched discs for maximum cutting action



Find more product features and options at **BUSHHOG®.com**

DHP SERIES PULL DISC HARROWS

MODELS: **DHP8** | **DHP10** | **DHP12**

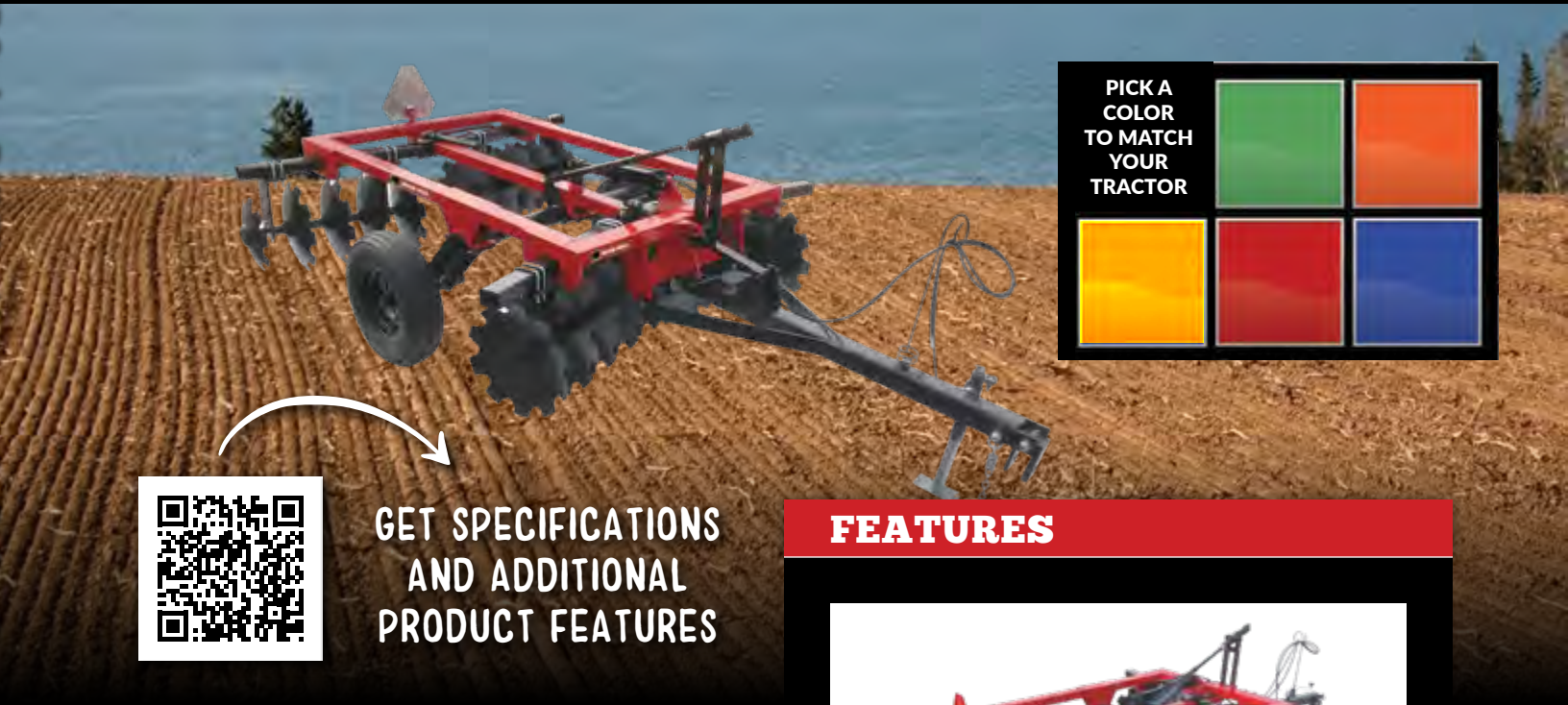

GET SPECIFICATIONS
AND ADDITIONAL
PRODUCT FEATURES

Bush Hog®'s pull disc harrows are designed for pulverizing soil, seed bed preparation and general tillage. Solidly built units available in widths of 8', 10' and 12', the DHP harrows are ideally suited for use by small acreage farmers, food plot managers, ranchers, construction crews and nursery operators.

The DHP Series shares many features available on larger, more expensive models, including front-to-rear leveling, a depth control system, adjustable-gang angles, and streamlined tubular gang hangers.

Multiple blade spacing options are available. Blade spacings of 7 ½" allow for fine, finish discing needed for seedbed preparation or 9" for breaking up and fracturing "new ground" or a combination of the two. Multiple blade spacing options for each model are available—20" or 22" notched discs at each of the following spacing options: 7 ½" front and rear, 9" front and rear, 9" front and 7 ½" rear. High-strength 1 ½" square gang axles, combined with tough gang components, and triple lip sealed ball bearings, ensure DHP models are ready for the toughest jobs.

FEATURES



Bearing hangers
reinforces with gussets



Notched discs for
maximum cutting action

- Square and rectangle tube steel frames and gang tubes
- Adjustable gang angles, front and rear
- Variable Blade Spacings Available:
9" front and rear gangs for tough-to-cut "New Ground";
7 ½" front and rear gangs for finer soil finishing;
9" front gangs/7 ½" rear gangs—the best of both worlds
- Optional disc scrappers



APP SERIES ALL-PURPOSE PLOWS

MODELS: APP48-3 | APP60-5 | APP66-5 | APP66-7 | APP85-7 | APP85-9



GET SPECIFICATIONS
AND ADDITIONAL
PRODUCT FEATURES

A simple tool to do serious work...

Bush Hog®'s line of All-Purpose Plows help you tackle a wide range of ground breaking tasks. These field cultivators break up, cultivate and aerate the ground in agricultural fields, food plots, gardens or anywhere you need to get something growing. Spring loaded, auto-reset shanks allow you to go where other tools can't... stumps, rocks and other obstacles will not keep you from breaking up "new" ground or reclaiming "old" ground.

With 3, 5, 7 and 9-shank models available, Bush Hog® has an all-purpose plow to meet your ground breaking needs.

FEATURES



Spring loaded, auto-reset shanks protect the implement when obstacles such as rocks, stumps or roots are encountered in rough ground.

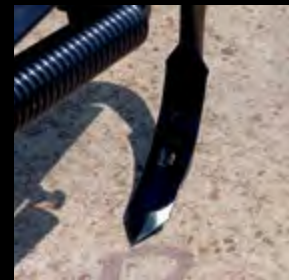

Heat treated shanks with replaceable points; points are 1080 high carbon steel hardened to 38 - 44 Rockwell C.



Easily adjustable shank spacing in 1" increments; heavy gauge 2 1/2" x 2 1/2" x 3/8" angle iron frame.



Find more product features and options at [BUSHHOG®.com](https://www.bushhog.com)

LP LAYOFF PLOW



GET SPECIFICATIONS
AND ADDITIONAL
PRODUCT FEATURES

Once a field has been broken and disked, the Bush Hog® LP Layoff Plow is used to make rows where crops are planted. The LP has a single, wide prong with a replaceable tip used to lay off and create a bed where you can plant your crops. After the rows are made, the planting can begin. In addition, the Bush Hog® LP Layoff Plow can be used for digging root type vegetables such as potatoes. The layoff plow is designed for 25 - 45 HP tractors with Category 1 Standard and Quick Hitch.

FEATURES



- 25 - 45 HP Tractors
- Category 1 Standard and Quick Hitch
- Wide Prong with a Replaceable Tip



HDSS SERIES HEAVY-DUTY SUBSOILERS

MODELS: HDSS1S | HDSS1L | HDSS2S | HDSS2L

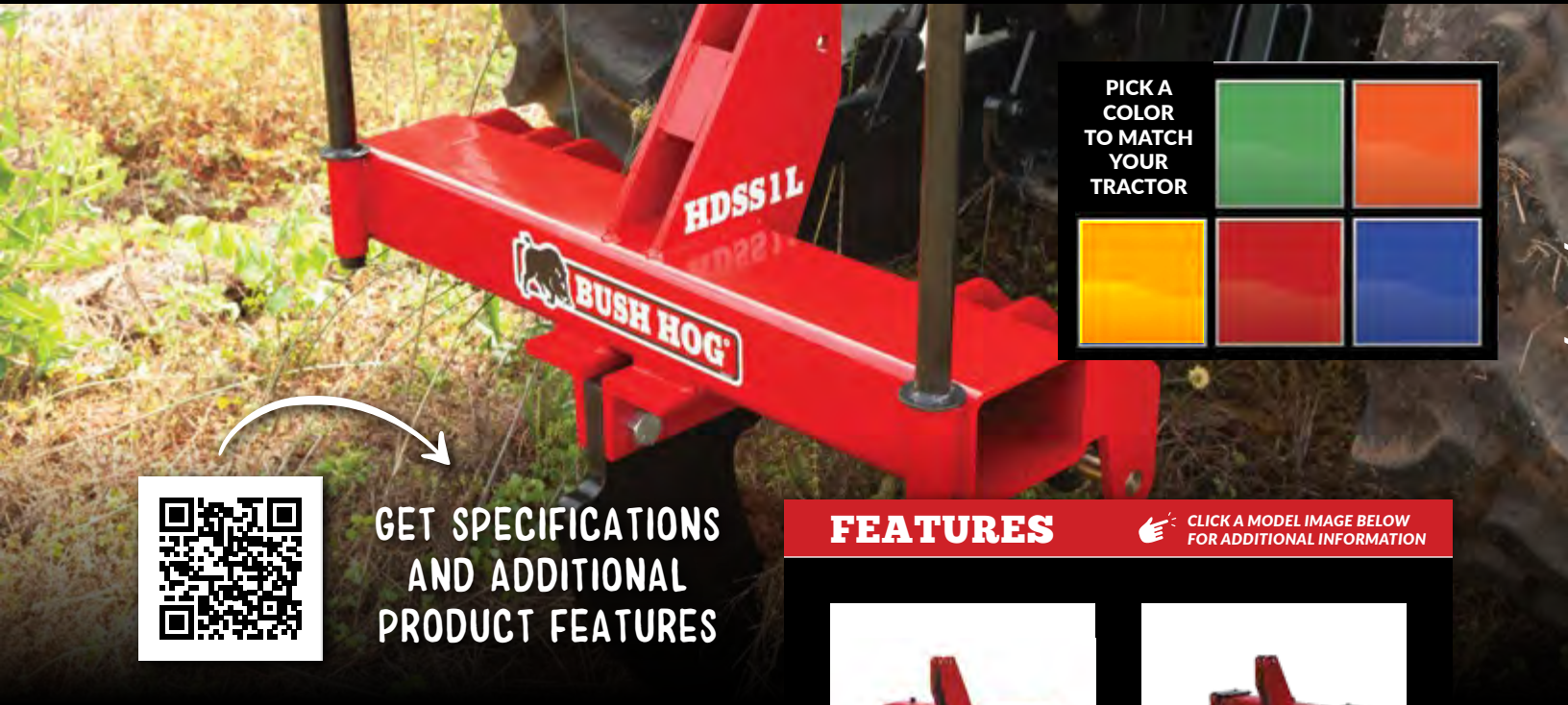

GET SPECIFICATIONS AND ADDITIONAL PRODUCT FEATURES

FEATURES

CLICK A MODEL IMAGE BELOW FOR ADDITIONAL INFORMATION



HDSS1S & HDSS1L

- Overall Width: 3'5"
- Weight: 261 lb. - 276 lb.
- Approx. 35 HP per shank up to 85 HP



HDSS2S & HDSS2L

- Overall Width: 3'5"
- Weight: 261 lb. - 276 lb.
- Approx. 35 HP per shank up to 85 HP

The 3-point heavy duty subsoilers from Bush Hog® are the right tool for you when breaking up a hardpan developed over years of heavy use. Compacted soil can hurt you in two ways: plant roots can't penetrate into the lower levels of the soil to tap additional nutrients and, in wet conditions, the excess water can't drain away...both weaken your plants and reduce your yields. The HDSS model subsoilers from Bush Hog® are available in four configurations, single or double shank with either short or long shank, capable of ripping the soil to depths ranging from 19" - 23" depending on the shank length. In certain areas, these subsoilers can be used to install water lines at depths suitable to get below the frost line. The beveled edge of the high carbon steel shank, combined with a heat-treated replaceable plow point, allow you to cut through the soil with minimal ground disturbance; shear pin protection is provided. When you need to go deep... the Bush Hog® HDSS subsoilers get the job done for you. Nothing beats a Bush Hog®!



Replaceable Heat-Treated Cutting Tip



1 1/4" wide Shanks



Parking Stands are Standard



Find more product features and options at [BUSHHOG®.com](https://www.bushhog.com)

SS1 SUBSOILER

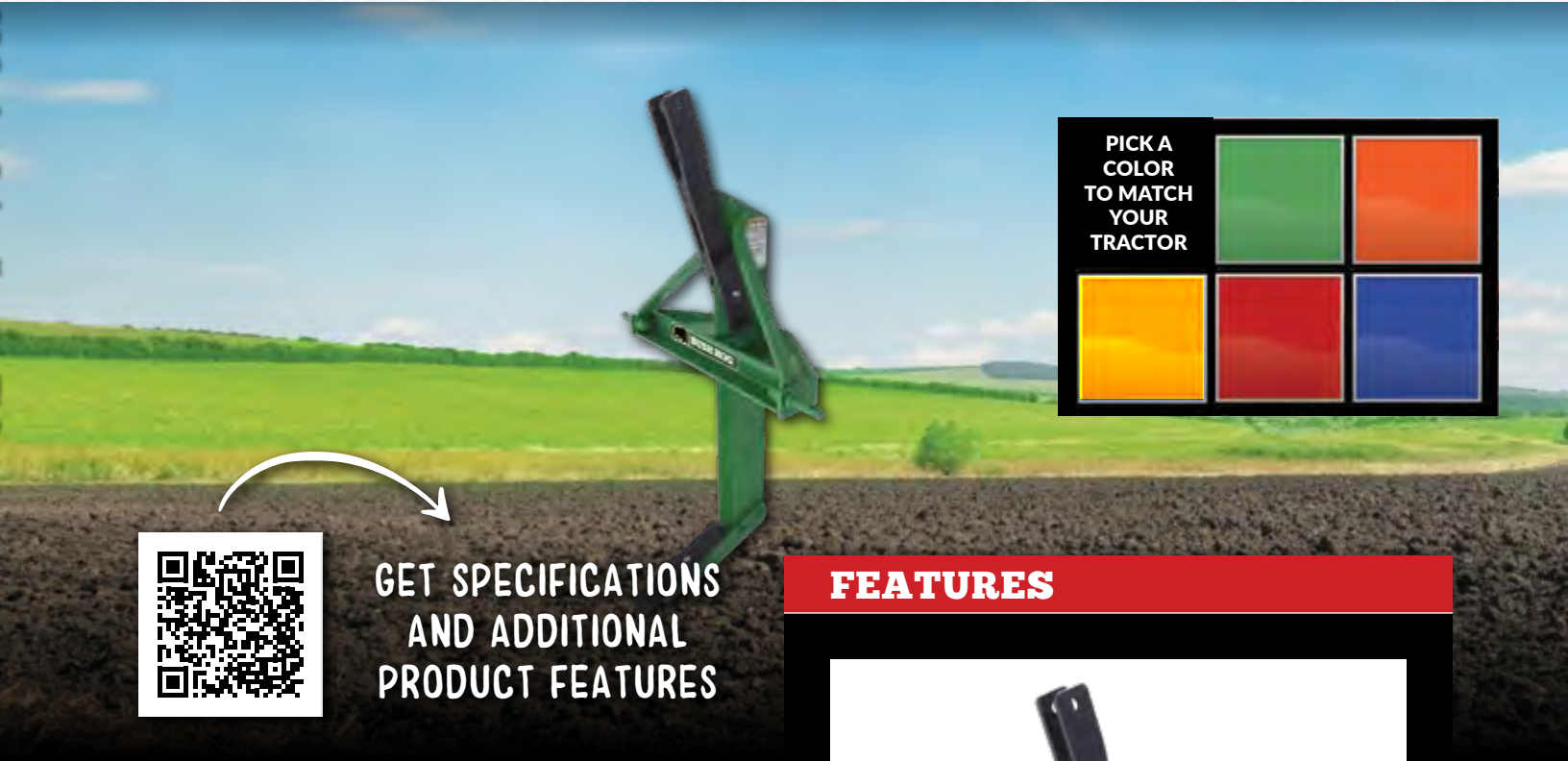

GET SPECIFICATIONS
AND ADDITIONAL
PRODUCT FEATURES



The 3-point standard duty subsoiler from Bush Hog® is the right tool for you when breaking up a hardpan developed over years. This subsoiler is available with a single shank equipped with a replaceable tip and is capable of ripping the soil a depth of 19". The beveled edge of the high carbon steel shank, combined with a heat-treated replaceable plow point, allows you to cut through the soil with minimal ground disturbance. Shear pin protection is provided. The SS1 is designed for 25 – 45 HP tractors with Category 1 Standard and Quick Hitch.

FEATURES



- Overall Width: 2'8 $\frac{3}{8}$ "
- Minimum HP Required: 25 – 45 HP
- Weight: 113 lb.



1RCV CULTIVATOR

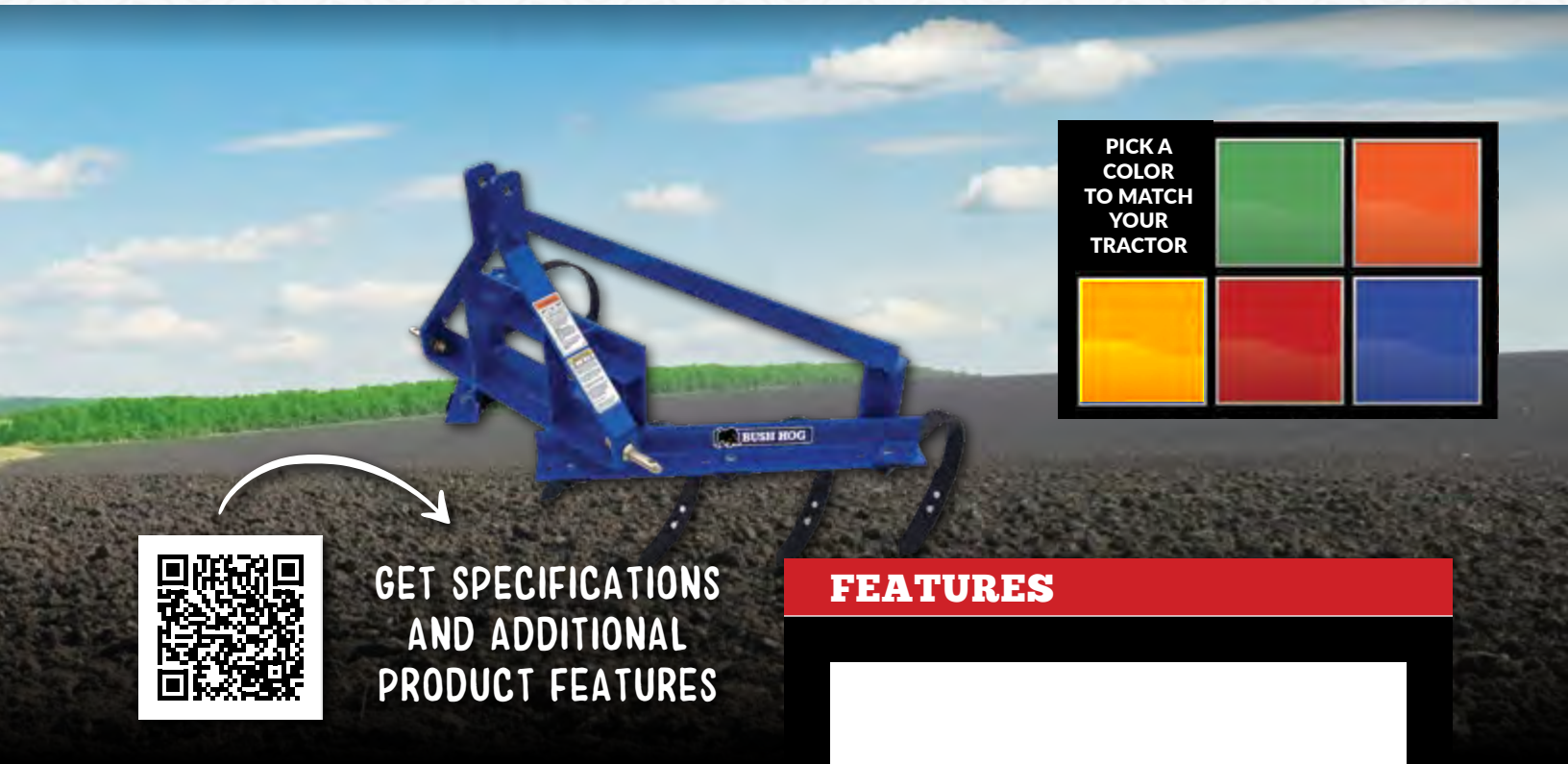

**GET SPECIFICATIONS
AND ADDITIONAL
PRODUCT FEATURES**

The Bush Hog® 1RCV Cultivator is ideal for aerating, stirring and pulverizing the soil to remove weeds, to prepare the ground before planting, or to loosen the soil after the crop has begun to grow. The 1RCV has 6 shanks with replaceable tips and is designed for 25 - 45 HP tractors with Category 1 Standard and Quick Hitch. The 1RCV has mounting holes in place for seed planters made by Covington® or Cole. This feature allows for reduced trips over the field and makes the implement even more valuable to you.

FEATURES



- 1RCV has 6 shanks with replaceable tips
- Category 1 Standard and Quick Hitch
- Overall Width: 4' 9 7/8"
- Minimum HP Require: 25 - 45 HP
- Weight: 117 lb.



Find more product features and options at **BUSHHOG®.com**

PA SERIES

PASTURE AERATORS

MODELS: PA8 | PA10

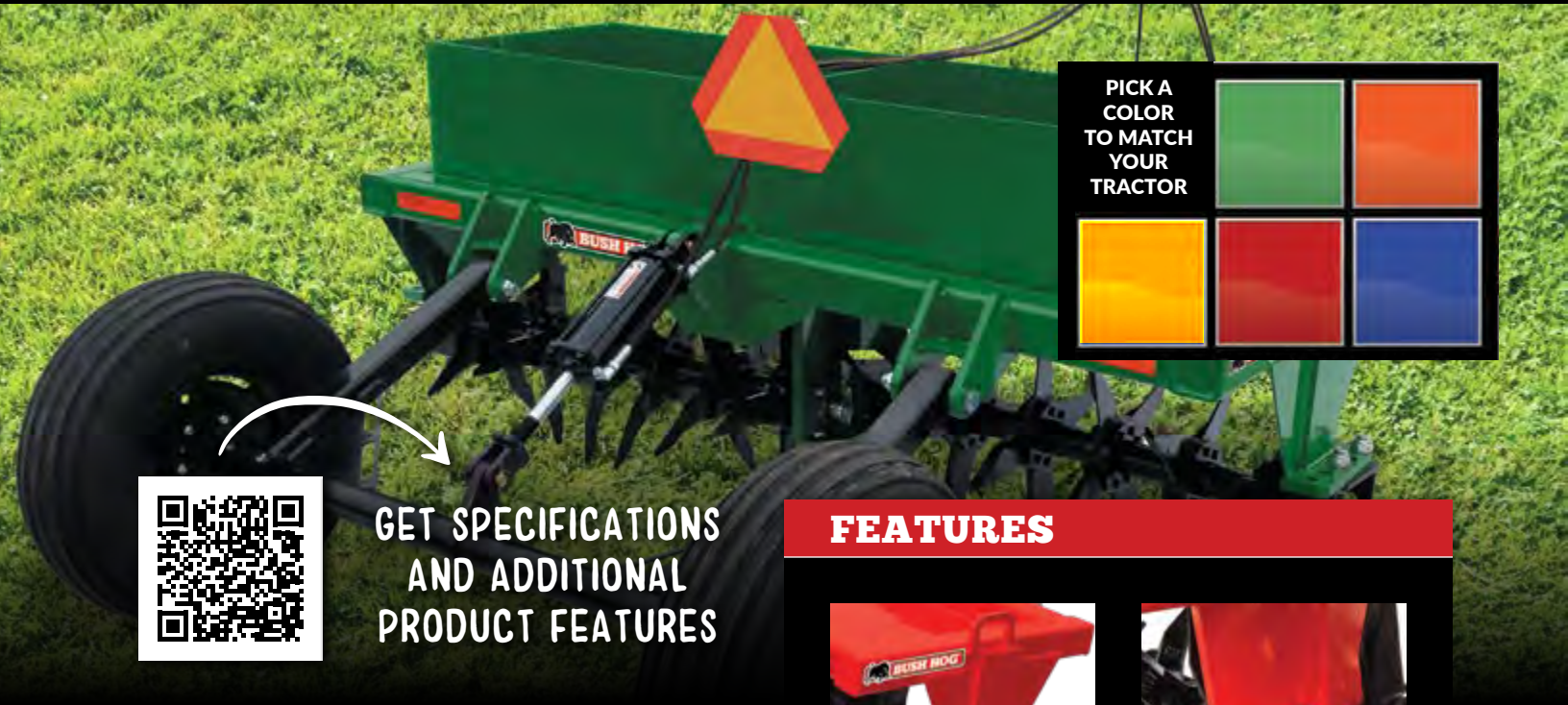

GET SPECIFICATIONS
AND ADDITIONAL
PRODUCT FEATURES

PICK A
COLOR
TO MATCH
YOUR
TRACTOR



FEATURES



Angled rotor adjustment from 2.5° to 7.5° allows the user to achieve even more soil fracturing as the gangs are offset



Heavy duty bearing hangers support the twisted shank rotors

The PA series pasture aerators from Bush Hog® are designed for use anywhere soil compaction exists. Available in 8' or 10' models, the PA series units are equipped with twisted shanks that serve both to lift and fracture compacted soil. This dual action design improves the intake of water and nutrients and creates improved soil growing conditions. The PA series aerators are ideal for a wide range of potential users including hay producers, cattlemen, sod farmers and landscapers. Give the PA series aerators a chance to make a difference in your soil's potential today!



Built-in weight box to ensure maximum soil penetration (weights not included)





HAY TOOLS



DHM SERIES

HAY MOWERS

MODELS: **DHM7** | **DHM8** | **DHM9** | **DHM10**



GET SPECIFICATIONS
AND ADDITIONAL
PRODUCT FEATURES

HAYMAKER by Bush Hog®

Bush Hog®'s four models of DHM hay mowers fit a large range of tractor sizes and production requirements. These mowers have Bush Hog®'s patented cutter bar design to handle your toughest mowing areas. With mowing widths ranging from 7' to 10', these mowers have been performance-proven with reduced wrapping and plugging issues in heavy and light hay crops. As always, they are built Bush Hog® tough to meet the hay production and service dependability requirements of today's farmers and ranchers.

FEATURES



DHM mowers have been performance tested and proven to reduce plugging and wrapping in both light and heavy hay crops.



Crop dividers come standard to provide clear distinction between cut and standing hay.



Oval discs allow for superior flow of material over the cutter bar and a better distribution of your hay crop.



HT SERIES

HAY TEDDERS

MODELS: **HT210** | **HT417** | **HT417H** | **HT419H**

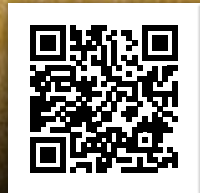

GET SPECIFICATIONS
AND ADDITIONAL
PRODUCT FEATURES

For the fastest drying time, choose Bush Hog®'s tedders!

We offer a choice of four different models, each built to accommodate your needs. Our tedders are designed for low horsepower tractors, with working widths from 10' to 19'. The Bush Hog® tedder produces quicker drying time for baling sooner and reduces possible damage to ground plants.

FEATURES

CLICK A MODEL IMAGE BELOW
FOR ADDITIONAL INFORMATION



HT210

- No. of Rotors: 2
- Apprx. Working Width: 10'
- Min. Required HP: 15 HP



HT417 & HT417H

- No. of Rotors: 4
- Apprx. Working Width: 17.1'
- Min. Required HP: 22 HP



HT419H

- No. of Rotors: 4
- Apprx. Working Width: 19'
- Min. Required HP: 25 HP



Anti-Wrap Stationary Disc



Clutch Protection



Find more product features and options at **BUSHHOG®.com**

XLRR-I SERIES PULL-TYPE V-RAKE HAY RAKES

MODELS: **XLRR819** | **XLRR1022** | **XLRR1226**



**GET SPECIFICATIONS
AND ADDITIONAL
PRODUCT FEATURES**

The XLRR-I independent suspension V-Rakes are the perfect raking tool for many hay producers looking for value and dependability with some special features designed in for good measure. The XLRR-I models come in 8, 10 and 12-wheel configurations. The units have a high clearance frame which handles heavy material volumes with ease and each wheel is independently suspended to provide optimum pickup of cut material while traveling over uneven terrain.

The unit folds to a narrow transport width and, in addition, the unit can be operated as a single-wheel unit if needed. Optional accessories such as a cab operated hydraulic windrow adjuster kit, a walking tandem wheel kit and a single-center kicker wheel kit can convert the XLRR-I units into a “next level” raking machine.

FEATURES



The XLRR-I V-Rakes feature independent wheel suspension on each wheel for unmatched performance when operating in rough or rolling terrain



Hydraulic windrow adjuster kit



Center wheel kit – hydraulic lift



EWR SERIES WHEEL-DRIVEN HAY RAKES

MODELS: **EWR820** | **EWR1023**

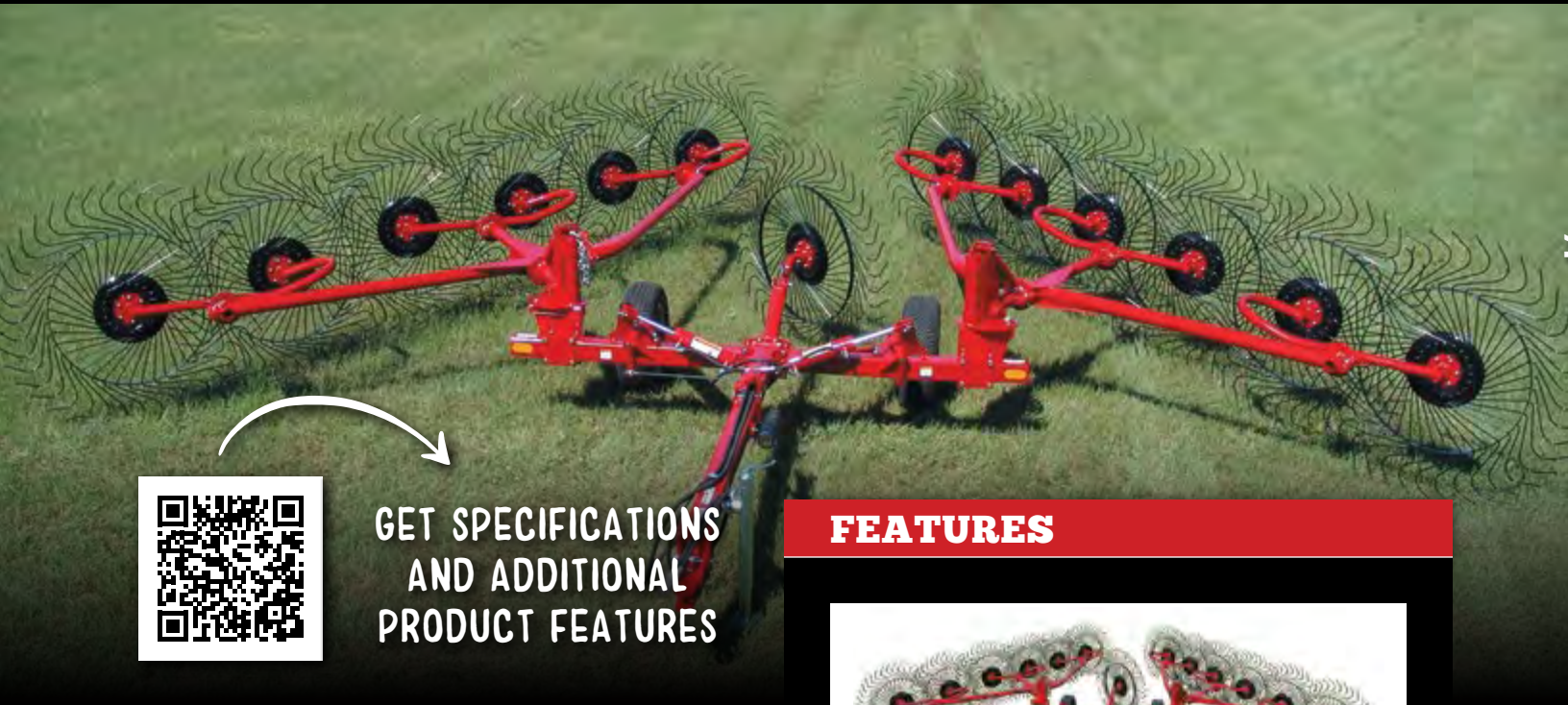

**GET SPECIFICATIONS
AND ADDITIONAL
PRODUCT FEATURES**

Our EWR Series wheel hay rakes are designed to make your harvesting faster, easier, and more efficient. With raking widths from 20' - 23', all our hay rakes are built to provide unrivaled performance in the toughest conditions, season after season. No matter the size, Bush Hog® has the dependability and range for your specific needs. When you need to rake a perfect swath, nothing beats a Bush Hog® for performance you can count on!

FEATURES



EWR wheel "V" rakes are available in 8 and 10 wheel models.



Adjustable windrow width



Wheel flotation for uneven ground



Spring adjustment for finger wheel ground pressure



Find more product features and options at **BUSHHOG®.com**

3PB SERIES 3-PT BALE IMPLEMENTS

MODELS: **3PBS1** | **3PBS2** | **3PBU**

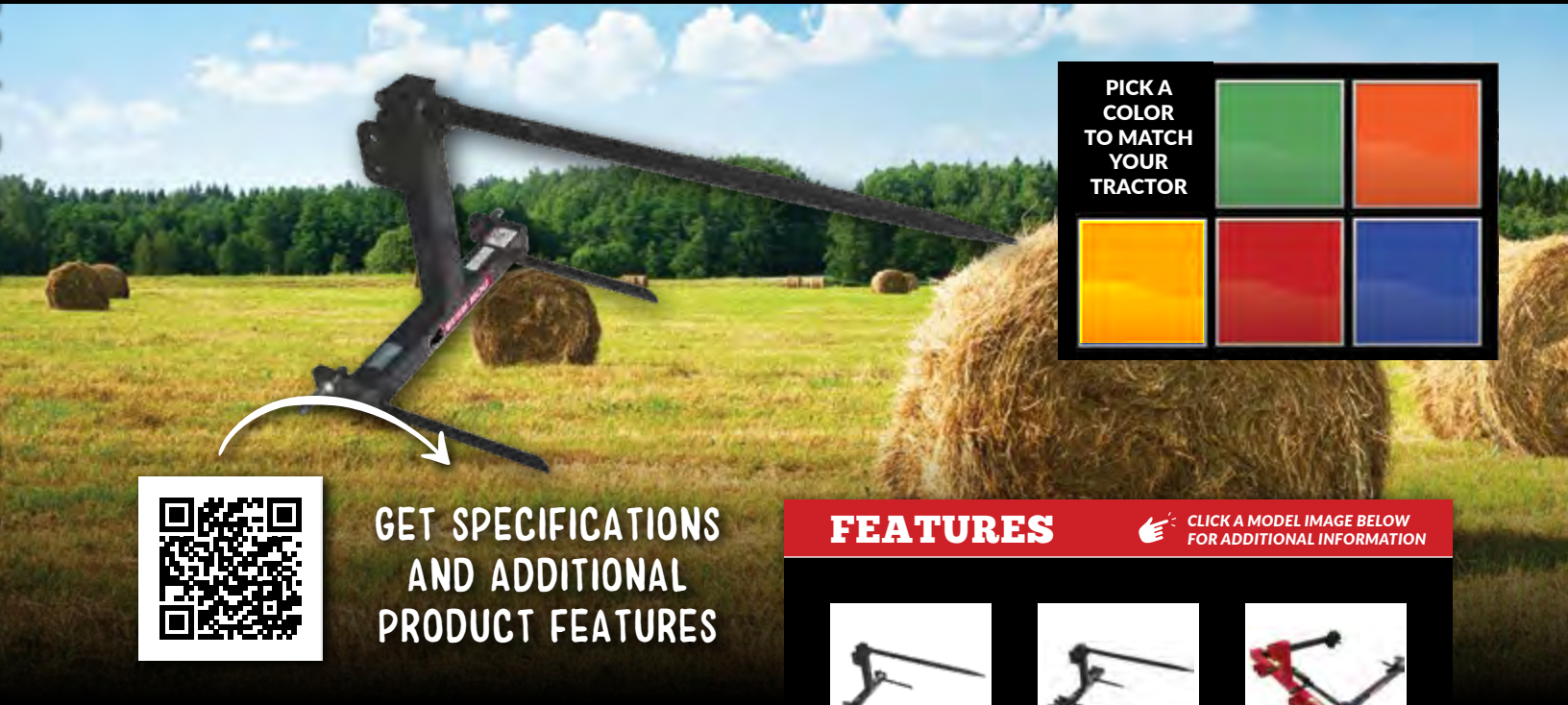

GET SPECIFICATIONS
AND ADDITIONAL
PRODUCT FEATURES

FEATURES

CLICK A MODEL IMAGE BELOW FOR ADDITIONAL INFORMATION



3PBS1
3-PT Single Probe
Bale Spear for
Cat. 1 Standard
and Quick Hitch



3PBS2
3-PT Single Probe
Bale Spear for Cat.
1 & 2 Standard and
Quick Hitch



3PBU
3-PT Bale Unroller
Cat. 1 & 2 Standard
and Quick Hitch

3-PT Bale Spears & Unrollers

An effective way to move or stack hay bales is with these economical 3-PT Bale Spears for handling round bales up to 2,000 lb. The 3-PT Bale Spears turn on a center axis to unroll bale. The units feature a main tapered spear 3'6" long and 2 welded balance spears. They are designed for 25 – 45 HP tractors to efficiently move hay bales without a loader. In combination with a loader on the front, the operator's efficiency is greatly improved. The units are powder coated with a durable black paint to give lasting protective finish. Each unit fits both Standard and Quick Hitches.

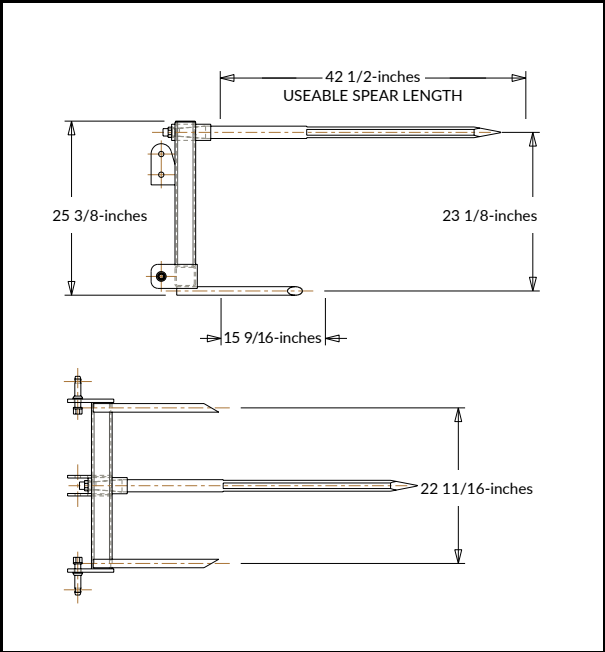

BSS & BSE SERIES TRACTOR-MOUNTED BALE SPEARS

MODELS: **BSSS-1** | **BSSS-2** | **BSSS-3** | **BSE-1**



GET SPECIFICATIONS
AND ADDITIONAL
PRODUCT FEATURES

Bush Hog®'s BSSS and BSE series bale spears are built Bush Hog® tough with a lift capacity of Over 4,000 lb. and capable of being mounted on a universal skid steer frame, these bale spears are designed to lift, transport and stack round or square bales of hay or other organic matter.

Also available in a Euro Mount configuration, let Bush Hog®'s bale spears help you get your work done faster.

FEATURES

CLICK A MODEL IMAGE BELOW FOR ADDITIONAL INFORMATION



BSSS-1

- Max. Load Capacity: 4,046 lb.
- Weight: 135 lb.
- Attachment Method: Cat 1 & 2 Std, Quick Hitch



BSSS-2

- Max. Load Capacity: 4,046 lb.
- Weight: 222 lb.
- Attachment Method: Cat 1 & 2 Std, Quick Hitch



BSSS-3

- Max. Load Capacity 4,046 lb.
- Weight: 230 lb.
- Attachment Method: Cat 1 & 2 Std, Quick Hitch

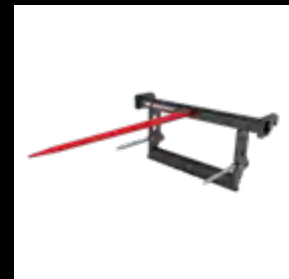

BSE-1

- Max. Load Capacity 4,046 lb.
- Weight: 121 lb.
- Attachment Method: Euro



Find more product features and options at **BUSHHOG®.com**

This page intentionally left blank.

SERIES: SBSA | SBDA | SBSS



SNOW BLOWERS



SNOW REMOVAL EQUIPMENT

SBSA SERIES SINGLE AUGER SNOW BLOWERS

MODELS: SBSA54 | SBSA60 | SBSA72 | SBSA78 | SBSA87 | SBSA97



GET SPECIFICATIONS AND ADDITIONAL PRODUCT FEATURES

FEATURES



MANUAL ROTATOR

Manual rotators are standard on SBSA54 and SBSA60 single auger models and can be optionally outfitted on most models where operators can safely reach the adjustment handle.



HIGH TENSILE STEEL RIBBON FLIGHTING

To deliver even the heaviest wet snow to the awaiting fan, Bush Hog® snow blowers use machine formed, hand welded augers made with high tensile steel ribbon fighting to provide strength and durability for years to come.



3-POINT / QUICK ATTACH

All single auger PTO driven models are built for Category 1 or Category 2 type 3-Point Hitch. Dual auger PTO driven models are built for Category 2 or Category 3 type 3-Point Hitch. All models are Quick Attach compatible.



FIVE-BLADE FAN

All Bush Hog® snow blowers now feature five-blade fans that not only evacuate high volumes of snow quickly, but also feature tighter tolerance to the housing—increasing velocity of the snow exiting the chute.

Single auger snow blowers from Bush Hog® easily cut through winter's icy grasp. High tensile steel fighting feeds snow to the 5-blade fan. Its tight tolerance to the housing sucks in the snow blowing it out of the chute with as little as 15 HP.

For convenience, snow blowers with a main body height of 2'1" come with a standard manual chute rotator. On larger blowers where operators may not be able to safely reach a manual rotator as standard equipment, all rotators are optional.



SBDA SERIES DUAL AUGER SNOW BLOWERS

MODELS: SBDA108 | SBDA1108A | SBDA1108B



GET SPECIFICATIONS
AND ADDITIONAL
PRODUCT FEATURES

FEATURES



HYDRAULIC ROTATOR

The optional hydraulic rotator is the ideal upgrade for tractors with cabs or for contractors/property managers needing to make frequent adjustments. Hydraulic rotators are standard equipment on SBDA108, SBDA1108A, and SBDA1108B models.



MANUAL DEFLECTOR

All Bush Hog® snow blowers come with a manual pin-style deflector allowing a true set it and forget approach to blowing snow.



FIVE-BLADE FAN

All Bush Hog® snow blowers now feature five-blade fans that not only evacuate high volumes of snow quickly, but also feature tighter tolerance to the housing—increasing velocity of the snow exiting the chute.



GEAR BOX

The time-proven comer gearbox transfers PTO power from the tractor into the driveline of the snow blower, ensuring consistent power input to the auger and fan assemblies.

Dual auger snow blowers from Bush Hog® work well in both acreage and commercial applications. These snow blowers accommodate an additional auger to help chew down the most stubborn of snow banks.

All dual auger model snow blowers feature skid shoes to help maintain consistent placement of the cutting edge and prevent surface damage.



Find more product features and options at **BUSHHOG®.com**

SBSS SERIES SKID STEER SNOW BLOWERS

MODELS: **SBSS760** | **SBSS761** | **SBSS762** | **SBSS763** | **SBSS764** | **SBSS765**



GET SPECIFICATIONS
AND ADDITIONAL
PRODUCT FEATURES

The hydraulic powered Bush Hog® snow blower provides year round benefits to skid loader owners with universal quick attach couplers.

For optimal performance, hydraulic motors need to be matched to the equipment's minimum GPM rating.

FEATURES



FIVE-BLADE FAN

All Bush Hog® snow blowers now feature five-blade fans that not only evacuate high volumes of snow quickly, but also feature tighter tolerance to the housing—increasing velocity of the snow exiting the chute.



SKID SHOES

Bush Hog® snow blowers come equipped with adjustable skid shoes, extending the life of the cutting edge and helping to protect surfaces from damage commonly associated with snow removal.



MANUAL DEFLECTOR

All Bush Hog® snow blowers come with a manual pin-style deflector allowing a true set it and forget approach to blowing snow.



HYDRAULIC DEFLECTOR

Hydraulic deflectors control the distance and arc of the thrown snow and are an available option on all snow blower models.





BUSH HOG® SNOW BLOWERS

SPECIFICATION COMPARISON

CONTINUED ON PAGE 98

	SBSA54	SBSA60	SBSA72	SBSA78	SBSA87	SBSA97	SBDA108	SBDA1108A	SBDA1108B
PRODUCT DESCRIPTION	54" Single Auger Snow Blower	60" Single Auger Snow Blower	72" Single Auger Snow Blower	78" Single Auger Snow Blower	87" Single Auger Snow Blower	97" Single Auger Snow Blower	Double Auger 108" Snow Blower	Double Auger 108" Snow Blower	Double Auger 108" Snow Blower
RECOMMENDED TRACTOR HP	15	20	35	50	60	75	Up to 175	Up to 175	Up to 175
CUTTING WIDTH	54"	60"	72"	78"	87"	97"	108"	108"	108"
CUTTING EDGE	3/8" x 1"	3/8" x 1"	3/8" x 1"	1/2" x 1 1/2"	1/2" x 2"	1/2" x 2"	1/2" x 6"	1/2" x 6"	1/2" x 6"
AUGER DIAMETER	14"	14"	14"	15"	19"	19"	19" (x1) 15" (x1)	19" (x1) 15" (x1)	19" (x1) 15" (x1)
FAN DIAMETER	21"	21"	21"	23"	27"	27"	32"	32"	32"
CHUTE DIAMETER	8"	8"	10"	10"	12"	12"	13"	13"	13"
CHUTE ROTATION (MAN/HYD)	Std./Opt.	Std./Opt.	Opt./Opt.	Opt./Opt.	Opt./Opt.	Opt./Opt.	Hydraulic	Hydraulic	Hydraulic
CHUTE DEFLECTOR (MAN/HYD)	Std./Opt.	Std./Opt.	Std./Opt.	Std./Opt.	Std./Opt.	Std./Opt.	Std/Opt	Std/Opt	Std/Opt
MAIN BODY HEIGHT	25"	25"	29"	29"	36"	36"	43"	43"	43"
HITCH (STANDARD & QUICK HITCH)	Cat. 1	Cat. 1	Cat. 1	Cat. 1 & 2	Cat. 2	Cat. 2	Cat. 2 & 3 Standard & Quick Hitch	Cat. 2 & 3 Standard & Quick Hitch	Cat. 2 & 3 Standard & Quick Hitch
WEIGHT (LB.)	366 lb.	396 lb.	540 lb.	748 lb.	1,034 lb.	1,106 lb.	1,980 lb.	1,980 lb.	1,980 lb.
WARRANTY	2-year Limited Machine Warranty; 5-Year Limited Gearbox Warranty	2-year Limited Machine Warranty; 5-Year Limited Gearbox Warranty	2-year Limited Machine Warranty; 5-Year Limited Gearbox Warranty	2-year Limited Machine Warranty; 5-Year Limited Gearbox Warranty	2-year Limited Machine Warranty; 5-Year Limited Gearbox Warranty	2-year Limited Machine Warranty; 5-Year Limited Gearbox Warranty	2-year Limited Machine Warranty; 5-Year Limited Gearbox Warranty	2-year Limited Machine Warranty; 5-Year Limited Gearbox Warranty	2-year Limited Machine Warranty; 5-Year Limited Gearbox Warranty

Specifications and design subject to change without notice.



Find more product specifications, features and options at **BUSHHOG.com**



BUSH HOG® SNOW BLOWERS

SPECIFICATION COMPARISON

CONTINUED FROM PAGE 97

	SBSS760	SBSS761	SBSS762	SBSS763	SBSS764	SBSS765
PRODUCT DESCRIPTION	Skid Steer 76" Snow Blower	Skid Steer 76" Snow Blower	Skid Steer 76" Snow Blower	Skid Steer 76" Snow Blower	Skid Steer 76" Snow Blower	Skid Steer 76" Snow Blower
RECOMMENDED TRACTOR HP						
CUTTING WIDTH	76"	76"	76"	76"	76"	76"
CUTTING EDGE	1/2" x 3"	1/2" x 3"	1/2" x 3"	1/2" x 3"	1/2" x 3"	1/2" x 3"
AUGER DIAMETER	19"	19"	19"	19"	19"	19"
FAN DIAMETER	32"	32"	32"	32"	32"	32"
CHUTE DIAMETER	11"	11"	11"	11"	11"	11"
CHUTE ROTATION (MAN/HYD)	Hydraulic	Hydraulic	Hydraulic	Hydraulic	Hydraulic	Hydraulic
CHUTE DEFLECTOR (MAN/HYD)	Std/Opt	Std/Opt	Std/Opt	Std/Opt	Std/Opt	Std/Opt
MAIN BODY HEIGHT	31"	31"	31"	31"	31"	31"
HITCH (STANDARD & QUICK HITCH)						
WEIGHT (LB.)	950 lb.	950 lb.	950 lb.	950 lb.	950 lb.	950 lb.
WARRANTY	2-year Limited Machine Warranty; 5-Year Limited Gearbox Warranty	2-year Limited Machine Warranty; 5-Year Limited Gearbox Warranty	2-year Limited Machine Warranty; 5-Year Limited Gearbox Warranty	2-year Limited Machine Warranty; 5-Year Limited Gearbox Warranty	2-year Limited Machine Warranty; 5-Year Limited Gearbox Warranty	2-year Limited Machine Warranty; 5-Year Limited Gearbox Warranty

Specifications and design subject to change without notice.



Find more product specifications, features and options at **BUSHHOG.com**

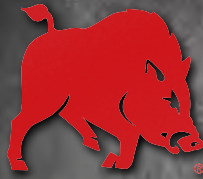

IF IT DOESN'T SAY
BUSH HOG®
IT JUST WON'T CUT IT™

The products, information, and images in this literature have been compiled for worldwide distribution. Some illustrations and text may include product options, accessories, and financing not available in all regions. Please visit Bush Hog®'s website or contact your local dealer for complete details. Bush Hog® reserves the right to improve our products and make changes to specifications, designs, pricing, and standard equipment without notice.

Always operate machines in accordance with supplied operators manuals. Visit bushhog.com/safety for safety information and materials.

Copyright ©2024 Bush Hog LLC. All rights reserved. Bush Hog®, the Bush Hog® logo, and the hog symbol are registered trademarks of Alamo Group Inc. All other trademarks, trade names, or service marks appearing in this brochure are the property of their respective companies or mark holders.

Revised 13 SEPTEMBER 2024

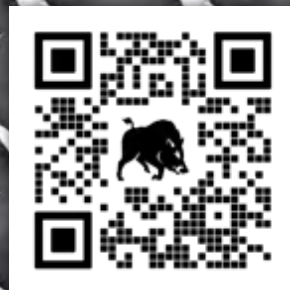

SCAN THE QR CODE WITH YOUR MOBILE DEVICE TO VIEW
THE LATEST DIGITAL VERSION OF OUR PRODUCT GUIDE

