



DEPENDABLE PUMPS & ACCESSORIES
FOR YOUR AGRICULTURAL AND INDUSTRIAL NEEDS



2024-2025
VOLUME XXVIII

johnblue.com

[@info@johnblue.com](mailto:info@johnblue.com)

[1-800-253-BLUE](tel:1-800-253-BLUE)

PRODUCT CATALOG



About Us

📍 165 Electronics Blvd. SW
Huntsville, AL 35824

☎ 1-800-253-BLUE

@ info@johnblue.com

🌐 johnblue.com

**AUTHORIZED
DEALER
NETWORK**



Genuine pumps, parts, and service are distributed through an extensive authorized dealer network. Visit the Dealer Locator on our website:

📍 johnblue.com/dealers



Reference
the John Blue
Catalog from
your devices!



John Blue Company: A Legacy of Excellence in Agricultural Pumps Since 1886

Founded in 1886, John Blue Company has been a trusted leader in the agricultural pump industry for over a century. Renowned for our commitment to quality and reliability, we offer a comprehensive range of pumps designed to meet the diverse needs of farmers and growers nationwide. Our product lineup includes piston pumps, centrifugal pumps, diaphragm pumps, spray pumps, and more, ensuring that we have the right solution for any application.

Located in Huntsville, Alabama, John Blue Company prides itself on delivering exceptional customer service and top-quality products. Whether you need a dependable pump for your farm or agricultural operation, you can rely on our expertise and experience to help you find the perfect fit. Choose John Blue Company for all your agricultural and industrial pump needs.



WE LOVE YOUR PRODUCTS!

- Fifth Generation Farmer

Table of Contents



- Company History & Timeline 2-3
- Product Spotlight 4-5
- Helpful Information..... 6

1 APPLICATION PUMPS AND ACCESSORIES

- Hydraulically and Ground Driven Complete Systems . 7-9
- Next-Generation Piston Pumps (NGP)..... 10-18
- DRV and Pump Drives..... 19-20
- Variable Rate Hydraulic Drive Kits..... 21-23
- Flow Dividers and Check Valves..... 24-25
- Flow Monitors (VisaGage II) and Orifice Selectors. .26-27
- Liquid Blockage Monitor System (LBMS) 28-32
- John Deere® Kits..... 33
- Squeeze Tube Pumps 34-36
- Manifolds 37
- Check Valves and Hose Barbs 38

2 CENTRIFUGAL PUMPS

- Polypropylene Centrifugal Pumps (PSP)..... 39-41
- Pedestal Mounts..... 40
- Pumps for De-icing 41
- Cast-Iron Pumps and Engines (SP) 42-45
- Spray Pumps 46-48

3 IRRIGATION INJECTION PUMPS

- Piston Metering Injection Pumps..... 49
- E-Z Meter Injection Pumps 50-51
- Injection Check Valves 52

4 DIAPHRAGM PUMPS

- Low-Pressure Poly Pumps 53-59
- Medium Pressure Pumps 60-62
- High Pressure Pumps 63-65
- Spray Control Units and Spray Guns 66-69
- Diaphragm Pumps Miscellaneous Kits..... 70-71
- Diaphragm Pumps In-Use 72

5 ANHYDROUS AMMONIA PRODUCTS (NH₃)

- Impellicone® Flow Dividers and Splitters 73
- NH₃ VisaGage II with LBMS 74-75
- Knives..... 76

6 SPECIALTY PUMPS

- Brass Gear Pumps..... 77
- Foam Markers 78-80
- 12-Volt Pump and Accessories 81
- 12-Volt Batch Controller..... 81
- 12-Volt Speed Controllers 82

7 MISCELLANEOUS ACCESSORIES, REPAIR KITS, AND SPROCKETS

- Miscellaneous Drive Components..... 83
- Seal & Gasket Repair Kits for Centrifugal Pumps. 83
- Seal Kits for Centrifugal Pumps..... 83
- Repair Kits for Pumps and Fittings 83-84
- Squeeze Pump Hoses and Miscellaneous Parts 85
- Operator Kits 85
- Conversion Kits 86
- Sprockets for Pumps without Clutch 86



Piston Pumps Cast-Iron Transfer Pumps Liquid Spray Pumps Poly Transfer Pumps Irrigation Pumps Chemical Spraying Pumps Flow Monitors



COMPANY HISTORY & TIMELINE

Nov. 28 1861

John Blue Sr. born in Scotland County, NC to Angus and Mary Ann McLaurin Blue. He was the eldest of 9 children.



1883

At the age of 22, John Blue paid his father, Angus Blue, \$2,000 for 100 acres of land and continued to improve and develop tools to use on cotton farms that would utilize mule power, rather than man power. He invented a cotton planter made of iron, and a machine to spread fertilizer.



1891

John Blue and his friend and fellow inventor Mr. McCormick, submit their first product patent for a stalk cutter. Two years later, John Blue submits his second patent for a fertilizer distributor and cotton planter.

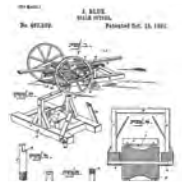

1945

10 years after John Sr.'s death, a fire destroyed the North Carolina foundry. Seeking a more convenient source of iron and coal, John Blue Jr. moved the company to a large foundry in Huntsville AL on Bob Wallace Avenue. Here, the company poured its own castings, and had its own welding and machine shops.



Mid-1960s

The Blue family sold the business to New York State firm Subscription Television Inc. (STV), but it kept the John Blue Company name.



1800

1886

1901

1960



Late 1800's

John Blue's curious mind, combined with the blacksmith skills he learned as a youth, led him to spend hours making farm tools in a small blacksmith shop on the family cotton farm.



1886

Blue and his father established a business on their land in Laurinburg NC, repairing cotton gin parts and working on farm tools. The business grew and a shop and foundry were built across the street so his inventions could be mass produced and sold to other cotton farmers. It operated for many years and still stands as the Museum of Agriculture and History.



Aug. 11 1901

John Blue Jr. was born, the youngest of 3. Over the years, he developed a very sharp business mind and set out to make implements available to all farmers while continuing to lower his cost of production. John Blue Jr. obtained patents for all of his inventions, including the Guano Distributor in 1937, and ensured that patents protected all of his improvements.



1952

In 1952, John Blue Jr. submitted the first patent from Huntsville Alabama for the first metering pump system. "LIQUID FERTILIZER APPLYING APPARATUS". The 1950's were a time of great innovation, and more than 20 patents were submitted over the next decade.



1961

Due to the increasing use of liquid fertilizer and liquid suspensions, the company devoted R&D to designing implements to handle it. In 1961, the John Blue tank division was created to fill this great need.

Dec. 10 1968

John Blue Jr. was killed in an auto accident. His legacy lives on through his descendants and through the John Blue Cotton Festival which is held every October at his childhood home in Laurinburg, NC.



By 1980

Ownership transitioned back into private hands, a division of Burnley Corporation. It marketed its products through branch Service Centers and a network of Authorized Sales & Service Dealers across the US and Canada. It purchased a building on Slaughter Rd. in Madison AL to house the "Rex" tank company.



1986

Major changes in the ag economy led the company to refine its product offering and focus on pumps, flow dividers, manifolds and accessories for applying liquid chemicals and fertilizers. The Bob Wallace location was liquidated at auction and many were laid off. The remaining business moved to Slaughter Rd.



2000

The company purchased CDS Ag Industries, a manufacturer of squeeze tube and irrigation pumps since 1980, and formed CDS-John Blue Company, a division of Advanced Systems Technology.



Aug. 2019

CDS-John Blue Company returned to its roots by becoming John Blue Company once again. The company now has over 50 patents and continues to develop high-quality, dependable, and accurate solutions to improve farming productivity and accuracy.

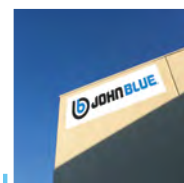

1970



1960s/70s

John Blue Company was an economic powerhouse in Huntsville, employing 700 to 800 at its peak. John Blue made pumps for agricultural and industrial operations, fertilizer spreaders, sprayers, cotton wagons, and metering devices for Anhydrous Ammonia. During 1974-76 John Blue also produced 200 Blue G-1000 tractors.

1980

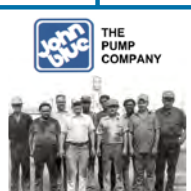

1985

The Rex tank company shut down when the farm economy crashed and plastic tanks rose in popularity. Production moved back to the Bob Wallace Ave. facility. A 10-month defense contract for ammunition boxes kept the company going during this time (it was the only item produced by the company).

2000

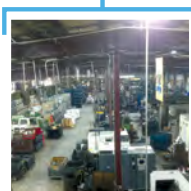

1995

With a resurgence in farming and equipment manufacturers, a new building was constructed on the west side of Slaughter Road (known as Pinehurst Drive) to accommodate the business and to modernize operations.

2024/25



2014

After steady growth and the addition of new liquid fertilizer products, the company outgrew its Pinehurst Drive building. It acquired a larger facility at 165 Electronics Blvd. near the Huntsville International Airport and Intermodal Center.



Future

We are committed to providing producers with the most reliable and accurate solutions at the best price, all while delivering quality engineered solutions and outstanding customer support. We embrace and promote the John Blue legacy and will never forget the passion and ingenuity of where we came from.

PRODUCT SPOTLIGHT

NEW 6HP HONDA ENGINE WITH ELECTRIC START

The 6HP Honda Engine with Electric Start is now available for our Centrifugal Cast-Iron, Poly, and Spray Pumps. Honda's GX series engines are legendary for superior reliability and performance. And there's no doubt about it, the GX200 lives up to the legend. Low noise levels, low vibration, and low emissions – without sacrificing power output or performance.



ELECTRIC START ENGINE JOHN BLUE CENTRIFUGAL PUMPS

- Easy Starting
- Exceptionally Quiet
- Smooth Performance
- Proven Reliability
- Double Wet Seal Technology
- Fully Assembled from Factory
- Durable Construction
- Vac-U-Seal Impeller

See Page.....40, 43, and 46

CS-155RG-6HE

E-Z METER INJECTION PUMP WITH NEW BASE

Boasting a lightweight yet robust design, the E-Z Meter is the ultimate solution for seamlessly moving between pivots. Its user-friendly setting system ensures effortless operation. It now features an all new easy-to-grab-and-move base!

Whether it's fertigation or chemigation, our pumps meet the client's needs with superior quality and reliability.

ASK US ABOUT OUR 7-DAY DRY TEST RUN!

FEATURES:

- Available in simplex and duplex models with numerous power sources.
- All parts exposed to agricultural products are made from 316 stainless steel, chemical resistant polypropylene and the highest quality seals available today.
- Accurate injection rates, maximum dependability and long-term reliability.

See Page.....50



LOW
MAINTENANCE

NO
CALIBRATION
TEST

AFFORDABLE
PRICE

NEW LBMS ENHANCEMENTS

New and improved features for Liquid Blockage Monitor System!

- Improved interface visibility
- Improved row blockage visibility
- “NEW” GPS coordinates will be logged at the time of blockage if tablet has GPS capability
- Smoother flow rate transitions
- Easy to read sensor settings
- User-friendly tool pane
- Durable Construction
- “NEW” calibration log for more detailed record keeping



See Page.....28

CENTRIFUGAL SPRAY PUMPS WITH 12 GPM HYDRAULIC MOTOR

The Centrifugal Spray Pump hydraulic motor has been totally reimagined - increased pump output performance, service life, and motor protection.



CS-150-HA12

- 158 GPM Max Flow
- 115 PSI Max Pressure
- 1-1/2" FPT & 220 Flanged Inlet
- 1-1/4" FPT & 200 Flanged Outlet

CS-200-HA12

- 173 GPM Max Flow
- 105 PSI Max Pressure
- 2" FPT Pump Inlet
- 1-1/2" FPT Pump Outlet

See Page.....47

3" PUMPS OPTIONAL POWER SOURCE

John Blue offers the Vanguard 400 EFI/ETC for our 3" poly and cast-iron centrifugal pumps. The 408cc engine is loaded with innovations and features to dominate any job.

- Features Electronic Fuel Injection (EFI) & Electronic Throttle Control (ETC) technologies
- TransportGuard® prevents damage by oil and fuel dilution during transport
- Backed by Vanguard's 3+1 Year Commercial Warranty

VANGUARD®

PSP-3340-G14V



SP-3350-G14V

14.0
Horsepower (HP)

408
Displacement (cc)

1
No. of Cylinders

Gas
Fuel Type

See Page.....40 and 43

ONLINE AUTHORIZED DEALER LOCATOR



Genuine pumps, parts, and service are distributed through an extensive authorized dealer network. Contact us to find your nearest dealer, or visit the Dealer Locator on our website.

johnblue.com/dealers »



ONLINE CALCULATORS QUICK REFERENCE:

CALCULATIONS AT YOUR DESK OR IN THE FIELD—WORKS ON DESKTOP AND MOBILE!

Our popular agricultural calculators are available for your John Blue ground driven piston pumps, squeeze pumps, hydraulically driven piston pumps, squeeze tube pumps, VisaGage II flow monitors, liquid and NH₃ blockage monitor systems. These calculators were developed to help you get the best results from your John Blue equipment by helping to identify and establish settings, application rates, and a variety of other useful parameters. Both English and metric units of measurement are supported. The calculators will work at home, in the office, or in the field and are designed specifically to work across most modern computers, tablets, and mobile phones.

Use the QR codes to quickly access the mobile version of the calculators!

Should you require assistance with one of these calculators, please call us toll free at 1-800-253-2583.

AVAILABLE CALCULATORS:



Hydraulic Drive Metering Piston Pumps:

Calculate your hydraulically driven metering pump's output in gallons/liters per revolution (GPR/LPR) and gallons/liters per minute (GPM/LPM), revolutions per minute (RPM), and the pump's respective setting. The calculator works in both standard and metric units.



Ground Drive Metering Pumps:

Calculates ground driven piston pump and squeeze tube pump settings, application rates, and other metering pump flow parameters.



VisaGage II and Liquid Blockage Monitor System (LBMS) Flow Monitors:

Calculates the corrected flow rate based on your fertilizer weight. In doing so, it determines the most suitable ball to use in your VisaGage II or LBMS flow monitor.



NH₃ VisaGage II with Liquid Blockage Monitor System (LBMS):

Calculates the corrected flow rate based on the amount of nitrogen being applied, your ground speed, and the distance between your crop rows. In doing so, the calculator determines the most suitable ball to use in your NH₃ VisaGage II with LBMS flow monitor.



Orifice Selector Plate Application Chart:

Use this chart to choose the correct orifice size for your application for water and solutions other than water.



APPLICATION PUMPS

APPLICATION PUMPS AND ACCESSORIES

For over 138 years, John Blue has been the leader in durable and trustworthy agricultural equipment. Our heritage is evident in our reliable metering pumps and accessories. Choose John Blue for the most precise fertilizer delivery systems on the market, backed by our dedicated support team, guaranteed to perform. Call our experts at 1-800-253-2583 for help selecting the perfect system for your needs.



1 APPLICATION PUMPS AND ACCESSORIES

Hydraulically and Ground Driven Complete Systems 7-9

Next-Generation Piston Pumps (NGP) 10-18

DRV and Pump Drives 19-20

Variable Rate Hydraulic Drive Kits 21-23

Flow Dividers and Check Valves 24-25

Flow Monitors (VisaGage II) and Orifice Selectors 26-27

Liquid Blockage Monitor System (LBMS). 28-32

John Deere® Kits. 33

Squeeze Tube Pumps 34-36

Manifolds 37

Check Valves and Hose Barbs 38

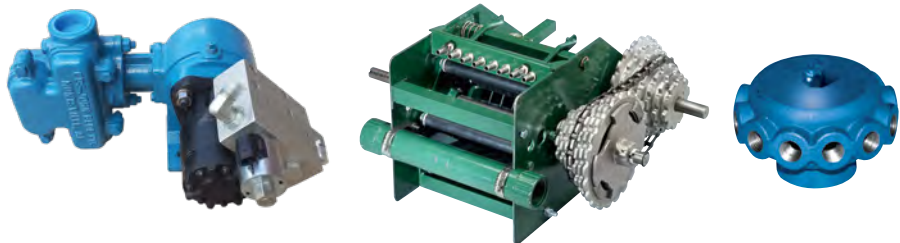

THE COMPLETE FERTILIZER PACKAGE



THE MOST RELIABLE LIQUID FERTILIZER SYSTEM ON THE MARKET TODAY IS SIMPLE.

FERTILIZER SYSTEM SCHEMATIC

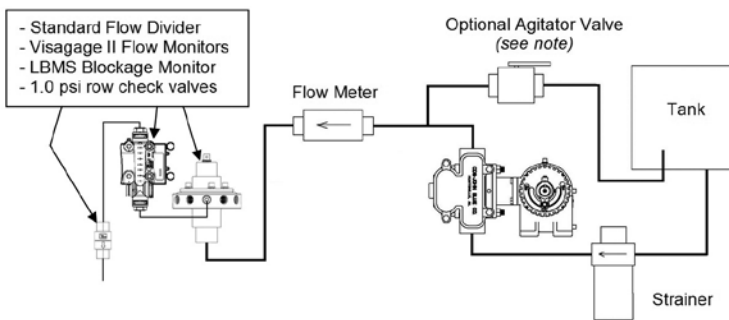

FERTILIZER SYSTEM SCHEMATIC WITH SECTION CONTROL

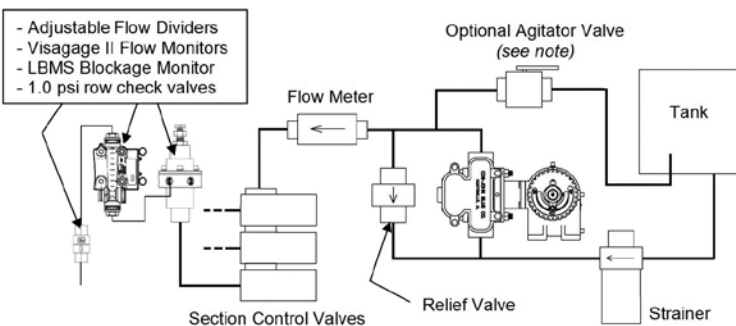

- A great system starts with a Next Generation Piston Pump.
- Choose to drive your system with a Variable Rate Hydraulic Drive (VRH) or a Ground Drive System (DRV).
- If needed, add a Pulsation Dampener for smooth application delivery for low-flow applications.
- Choose a divisional system for equal distribution and accuracy.
- Add the VisaGage II to monitor your flow or couple the VisaGage II to the Liquid Blockage Monitor System (LBMS). With LBMS you will know the flow from your tractor cab.
- Add in-line check valves to stop unwanted dripping at the application point.
- Set the fertilizer rates and get the job done.

Typical schematic for a hydraulically driven system. Flow meters are only necessary with a hydraulically driven system and are not necessary or typically used for a ground driven system.

THE JOHN BLUE COMPLETE SYSTEM

THE JOHN BLUE COMPLETE SYSTEM IS:

Accurate: Application rates DO NOT change due to temperature fluctuations.

Precise: A John Blue Piston Pump can pull product from your tanks for even application rates.

Flexible: Available with either a Variable Rate Hydraulic or Ground Drive Kit.

Reliable: Built to last, engineered for performance.



HOW TO SELECT A COMPLETE FERTILIZER PACKAGE:

- How many rows do you have?
- What is your swath width (row spacing distance multiplied by # of rows)?
- What application rate do you want to achieve?

SELECT THE PISTON PUMP THAT BEST FITS YOUR NEEDS.

(see charts under each pump series description pages 10-18).

CHOOSE TO DRIVE YOUR SYSTEM WITH A VARIABLE RATE HYDRAULIC DRIVE (VRH) OR A GROUND DRIVE SYSTEM (DRV):

DRV KITS: (PAGES 19-20)

- DRV-3300 Complete Ground Drive System, including pump mount and drive. It automatically adjusts for your terrain.
- DRV-3200 Universal Mount that uses the existing shaft from your planter.
- DRV-3100 Gauge Wheel only.
- DRV-3000 is ideal for fixed height. Includes pump mount and drive.

VRH KITS: (PAGES 21-23)

Bar mount and direct drive kits to fit common electronic packages:

- JD series fits John Deere® CANbus Planters using GreenStar™ GS2 and GS3
- PWM (pulse width modulation) series is for Raven®, Ag Leader®, Dickey-john® and others. Used for variable rate and sectional shut-off.
- MAN (manual) series uses your tractor's hydraulics for a simple hydraulically driven system.



LOW-FLOW APPLICATION THAT NEEDS VERY SLOW PUMP RPM? (PAGE 21)

- Our Pulsation Dampener allows the piston pump to be turned slower for low application rates, delivering fertilizer smoothly across your field.
- It conveniently threads directly into the outlet port of your piston pump or plumbed remotely into your discharge line.
- Constructed of robust schedule 80 PVC pipe, it forms an air cushion in the 1 ½" pipe body making the flow extremely smooth.

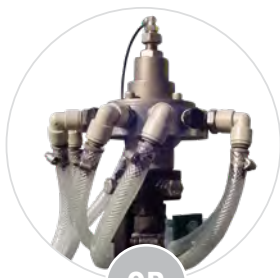

OR



CHOOSE A DIVISIONAL SYSTEM FOR EQUAL DISTRIBUTION:

FLOW DIVIDERS: LOW PRESSURE, SELF-ADJUSTING DIVISION (PAGE 24)

- How many outlets do you need?
 For 6 outlets or sectional shutoff select the FD-0610.
 For 12 outlets or less select the FD-1210.
 For 20 outlets or less select the FD-2010.

OR ORIFICE SELECTOR: HIGH PRESSURE, FIXED DIVISION (PAGE 26)

1. Turn your John Blue Visagage II into a self-contained orifice changing system
2. Simply select from one of four orifice settings on each disc. Four discs provide for sixteen different options.
3. Adjustment is quick no need to travel to each row unit and work with plumbing near the ground



KNOW YOUR FLOW™ WITH VISAGAGE FLOW MONITORS AND THE LIQUID BLOCKAGE MONITOR SYSTEM: (PAGES 26-32)

- Determine the number of outlets you need.
- Bank together single columns, sets of four, or any combination you choose. Clasp them together with the stainless steel clips and Viton® o-rings and its ready to go.
- Couple it to LBMS and see both low-flow and no-flow from your tractor cab with the Premium Wireless System, Standard Control Wired Panel, or ISOBUS system.

“ LONGTIME AG CUSTOMER...
 LOVE YOUR PUMPS!!
 – THOMAS

NGP PISTON PUMPS

NGP-6055-HY

All John Blue Ag Piston Pumps have been designed, engineered, and extensively field tested to set the standard for liquid metering pumps.

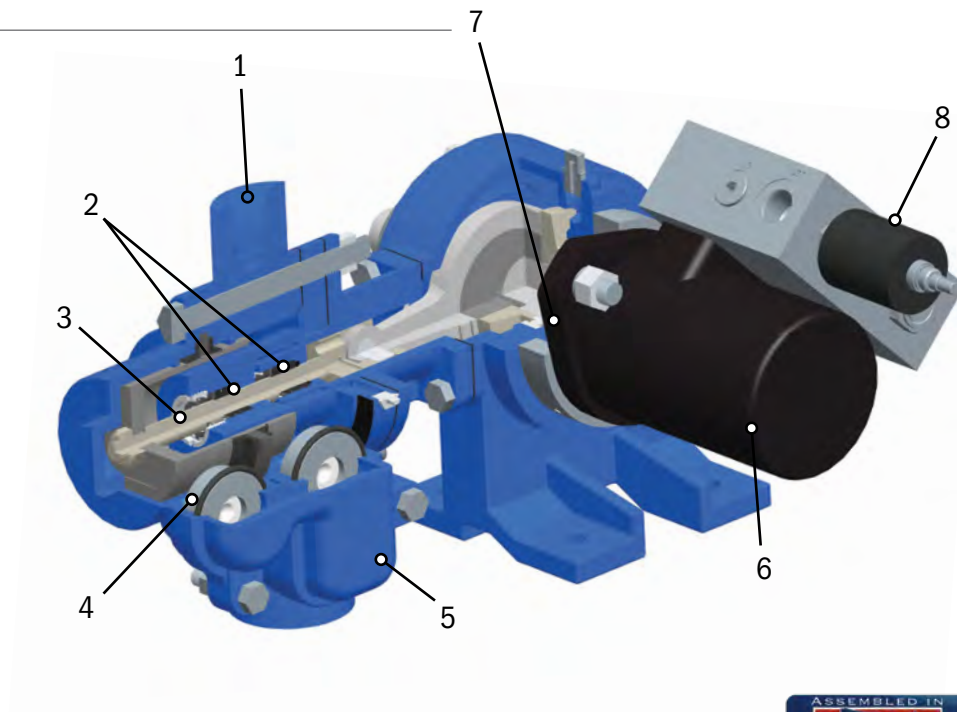

NEXT GENERATION PISTON PUMP FEATURES:

1. Inlet and Outlet Flanges make it easier to plumb your system and eliminate leaks with flange fittings. (Add -F after model number).
2. Double piston rod seals work in unison to offer multiple stage protection between the wet end and crankcase.
3. Outboard cylinder plunger packing can be inspected or replaced in the field without removing the hoses.
4. Check Valves are designed for positive seal, easy priming and long life.
5. Single Valve Cap provides easy access to check valves without removing the hoses. Simple to service in the field.
6. Common or Independent Manifolds are available on the double pumps. Independent manifolds allow for dual flow divider usage or half-width application.
7. Main Shaft Seals incorporate a dual wiper that is enclosed in a grease cavity to flush out contamination. This helps to extend the life of the pump.
8. Direct Hydraulic Drive Piston Pumps are available along with standard Ground Drive (DRV) and Variable Rate Hydraulic Drive Kits (VRH).

Note: All standard Piston Pumps are cast iron and manufactured with Viton® Piston Packings and Buna O-rings and rod packings. Most commonly used with liquid fertilizers that have pH greater than 5 and standard herbicides that are compatible with Buna and Viton®.

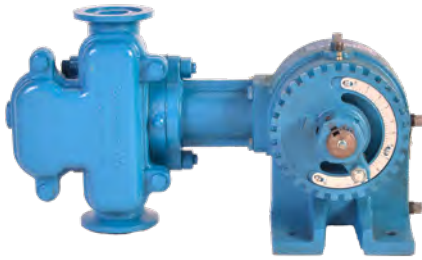

NGP-4055-F SERIES

Single Piston - Double Acting	Rated Speed - 450 RPM
Stroke - Variable	Inlet - 1" Inlet, 200 series flanges standard
Rated Flow - 10.2 GPM	Outlet - 1" Inlet, 200 series flanges standard
Rated Pressure - 120 PSI	Clutch - No Clutch



NGP-4055-HYF (HYDRAULIC DRIVE PISTON PUMP)

Single Piston - Double Acting	Rated Speed - 550 RPM
Stroke - Fixed	Inlet/Outlet - 1" inlet, 200 series flanges standard
Rated Flow - 10.2 GPM	Rated Pressure - 120 PSI
Accepts SAE A 2-bolt hydraulic motor with 1" shaft	

HYDRAULIC MOTOR/PWM MANIFOLD KITS AVAILABLE:

116205-91:	Flow-thru style manifold
116205-91D:	Dead-head style manifold

Rows	Swath in Inches		NGP-4055-F Application Range in GPA at 5 MPH			
			30 Inch Spacing		36 Inch Spacing	
			Min	Max	Min	Max
4	120	144	4.5	101.0	3.7	84.2
8	240	288	2.2	50.5	1.9	42.1
12	360	432	1.5	33.7	1.2	28.1
16	480	576	1.1	25.2	0.9	21.0
24	720	864	0.7	16.8	0.6	14.0
36	1080	1296	0.5	11.2	0.4	9.4

All calculations based on ground speed of 5 MPH. Rated Flow Based on 12 lbs. per gallon fertilizer.



NGP-5055-DRF SERIES

Double Piston - Double Acting	Rated Speed - 450 RPM
Stroke - Variable	Inlet - 1" Inlet, 200 series flanges standard
Rated Flow - 20.4 GPM	Outlet - 1" Inlet, 200 series flanges standard
Rated Pressure - 120 PSI	Clutch - No Clutch

Rows	Swath in Inches		NGP-5055-DRF Application Range in GPA at 5 MPH			
			30 Inch Spacing		36 Inch Spacing	
			Min	Max	Min	Max
4	120	144	9.2	207.9	7.7	173.3
8	240	288	4.6	104.0	3.9	86.6
12	360	432	3.1	69.3	2.6	57.8
16	480	576	2.3	52.0	1.9	43.3
24	720	864	1.5	34.7	1.3	28.9
36	1080	1296	1.0	23.1	0.9	19.3

All calculations based on ground speed of 5 MPH. Rated Flow Based on 12 lbs. per gallon fertilizer.



NGP-5655-ARF SERIES

Double Piston - Double Acting	Rated Speed - 450 RPM
Stroke - Variable	Clutch - No Clutch
Rated Pressure - 120 PSI	
Rated Flow: 31.2 GPM total; 10.2 GPM small side; 21 GPM large side	
Inlet/Outlet small cylinder head - 1" FPT 200 series flanges	
Inlet/Outlet large cylinder head - 1 ½" FPT 220 series flanges	

- » Apply two products at two rates with one pump
- » Max ratio 10 to 1, min ratio 2 to 1

Rows	Swath in Inches		NGP-5655-ARF Application Range in GPA at 5 MPH (small side of pump)			
			30 Inch Spacing		36 Inch Spacing	
	30	36	Min	Max	Min	Max
4	120	144	4.6	104.0	3.9	86.7
8	240	288	2.3	52.0	2.0	43.3
12	360	432	1.6	34.7	1.3	28.9
16	480	576	1.2	26.0	1.0	21.7
24	720	864	0.8	17.4	0.7	14.5
36	1080	1296	0.5	11.6	0.5	9.7

The chart above is for the small side of the pump. Calculate first the small side and then calculate the large side with the chart below
All calculations based on ground speed of 5 MPH. Rated Flow Based on 12 lbs. per gallon fertilizer.

Rows	Swath in Inches		NGP-5655-ARF Application Range in GPA at 5 MPH (large side of pump)			
			30 Inch Spacing		36 Inch Spacing	
	30	36	Min	Max	Min	Max
4	120	144	9.2	207.9	7.7	173.3
8	240	288	4.6	104.0	3.9	86.6
12	360	432	3.1	69.3	2.6	57.8
16	480	576	2.3	52.0	1.9	43.3
24	720	864	1.5	34.7	1.3	28.9
36	1080	1296	1.0	23.1	0.9	19.3

The chart above is for the large side of the pump.
All calculations based on ground speed of 5 MPH. Rated Flow Based on 12 lbs. per gallon fertilizer.

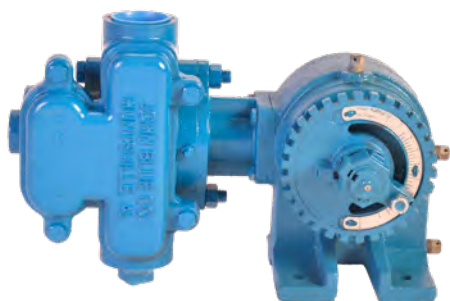

NGP-6050 SERIES

Single Piston - Double Acting	Rated Speed - 450 RPM
Stroke - Variable	Inlet - 1 ½" FPT
Rated Flow - 21.0 GPM	Outlet - 1 ½" FPT
Rated Pressure - 120 PSI	Clutch - Various Options

MODELS AVAILABLE:

NGP-6050	Rope Control Clutch
NGP-6055	Without Clutch
NGP-6058	Electric Control Clutch
NGP-6059	Hydraulic Control Clutch



NGP-6055-HYF (HYDRAULIC DRIVE PISTON PUMP)

Single Piston - Double Acting	Rated Speed - 550 RPM
Stroke - Fixed	Inlet/Outlet-1 ½" inlet, 220 series flanges optional
Rated Flow - 21.0 GPM	Rated Pressure - 120 PSI
Accepts SAE A 2-bolt hydraulic motor with 1" shaft	

Use with a John Blue Hydraulic Motor/PWM Manifold Kit.

MODELS AVAILABLE:

NGP-6055-HYF	Includes flange
NGP-6055-HY	Without flange



HYDRAULIC MOTOR/PWM MANIFOLD KITS:

116205-91:	Flow-thru style manifold (shown)
116205-91D:	Dead-head style manifold

Rows	Swath in Inches		NGP-6055 Application Range in GPA at 5 MPH			
			30 Inch Spacing		36 Inch Spacing	
	30	36	Min	Max	Min	Max
4	120	144	9.2	207.9	7.7	173.3
8	240	288	4.6	104.0	3.9	86.6
12	360	432	3.1	69.3	2.6	57.8
16	480	576	2.3	52.0	1.9	43.3
24	720	864	1.5	34.7	1.3	28.9
36	1080	1296	1.0	23.1	0.9	19.3

All calculations based on ground speed of 5 MPH. Rated Flow Based on 12 lbs. per gallon fertilizer. 316 SS available on wet end casting.



NGP-7050 SERIES

Single Piston - Double Acting	Rated Speed - 450 RPM
Stroke - Variable	Inlet - 1 1/2" FPT
Rated Flow - 34.2 GPM	Outlet - 1 1/2" FPT
Rated Pressure - 120 PSI	Clutch - Various Options

MODELS AVAILABLE:

NGP-7050	Rope Control Clutch
NGP-7055	Without Clutch
NGP-7058	Electric Control Clutch
NGP-7059	Hydraulic Control Clutch

Additional model options, including flanges, on page 18



NGP-7055-HY (HYDRAULIC DRIVE PISTON PUMP)

Single Piston - Double Acting	Rated Speed - 550 RPM
Stroke - Fixed	Inlet/Outlet-1 1/2" inlet, 220 series flanges optional
Rated Flow - 34.2 GPM	Rated Pressure - 120 PSI
Accepts SAE A 2-bolt hydraulic motor with 1" shaft	

Use with a John Blue Hydraulic Motor/PWM Manifold Kit.

MODELS AVAILABLE:

NGP-7055-HYF	Includes flange
---------------------	-----------------



HYDRAULIC MOTOR/PWM MANIFOLD KITS:

- 116205-91:** Flow-thru style manifold (shown)
- 116205-91D:** Dead-head style manifold

Rows	Swath in Inches		NGP-7050 Application Range in GPA at 5 MPH			
			30 Inch Spacing		36 Inch Spacing	
			Min	Max	Min	Max
	30	36				
4	120	144	15.0	338.6	12.5	282.2
8	240	288	7.5	169.3	6.3	141.1
12	360	432	5.0	112.9	4.2	94.1
16	480	576	3.8	84.6	3.1	70.5
24	720	864	2.5	56.4	2.1	47.0
36	1080	1296	1.7	37.6	1.4	31.4

All calculations based on ground speed of 5 MPH. Rated Flow Based on 12 lbs. per gallon fertilizer. 316 SS available on wet end casting.



NGP-8050 SERIES

Double Piston - Double Acting	Rated Speed - 450 RPM
Stroke - Variable	Inlet - 1 1/2" FPT
Rated Flow - 42 GPM	Outlet - 1 1/2" FPT
Rated Pressure - 120 PSI	Clutch - Various Options

MODELS AVAILABLE:

NGP-8050	Rope Control Clutch
NGP-8055	Without Clutch
NGP-8058	Electric Control Clutch
NGP-8059	Hydraulic Control Clutch
NGP-8055-DR	Pump with independent dual inlet & outlet manifolds

Rows	Swath in Inches		NGP-8055 Application Range in GPA at 5 MPH			
			30 Inch Spacing		36 Inch Spacing	
	30	36	Min	Max	Min	Max
4	120	144	18.5	415.8	15.4	346.5
8	240	288	9.2	207.9	7.7	173.3
12	360	432	6.2	138.6	5.1	115.5
16	480	576	4.6	104.0	3.9	86.6
24	720	864	3.1	69.3	2.6	57.8
36	1080	1296	2.1	46.2	1.7	38.5

All calculations based on ground speed of 5 MPH. Rated Flow Based on 12 lbs. per gallon fertilizer. 316 SS available on wet end casting.

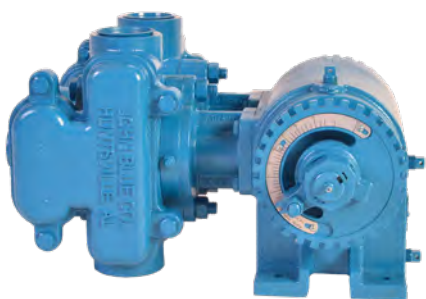

NGP-8055-AR DUAL RATE PISTON PUMP

Double Piston - Double Acting	Rated Speed - 450 RPM	Rated Pressure: 120 PSI
Stroke - Variable	Inlet - 1 1/2" FPT	
Rated Flow - 42 GPM total	Outlet - 1 1/2" FPT	
21 GPM per side	Clutch - No Clutch	

- » Apply two products at two rates with one pump
- » Max ratio 5 to 1

Rows	Swath in Inches		NGP-8055 Application Range in GPA at 5 MPH			
			30 Inch Spacing		36 Inch Spacing	
	30	36	Min	Max	Min	Max
4	120	144	9.2	207.9	7.7	173.3
8	240	288	4.6	104.0	3.9	86.6
12	360	432	3.1	69.3	2.6	57.8
16	480	576	2.3	52.0	1.9	43.3
24	720	864	1.5	34.7	1.3	28.9
36	1080	1296	1.0	23.1	0.9	19.3

The chart above is for one side of the pump. Calculate first one side of the pump and then calculate the second side.

All calculations based on ground speed of 5 MPH. Rated Flow Based on 12 lbs. per gallon fertilizer. 316 SS available on wet end casting.



NGP-9050 SERIES

Double Piston - Double Acting	Rated Speed - 450 RPM
Stroke - Variable	Inlet - 1 ½" FPT
Rated Flow - 68.4 GPM	Outlet - 1 ½" FPT
Rated Pressure - 120 PSI	Clutch - Various Options

MODELS AVAILABLE:

NGP-9050	Rope Control Clutch
NGP-9055	Without Clutch
NGP-9058	Electric Control Clutch
NGP-9059	Hydraulic Control Clutch
NGP-9055-DR	Pump with independent dual inlet and outlet manifolds



NGP-9055-HY (HYDRAULIC DRIVE PISTON PUMP)

Double Piston - Double Acting	Rated Speed - 550 RPM
Stroke - Fixed	Inlet/Outlet-1 ½"
Rated Flow - 68.4 GPM	Rated Pressure - 120 PSI
Accepts SAE A 2-bolt hydraulic motor with 1" shaft	

Use with a John Blue Hydraulic Motor/PWM Manifold Kit.



HYDRAULIC MOTOR/PWM MANIFOLD KITS:

- 116205-91:** Flow-thru style manifold (shown)
- 116205-91D:** Dead-head style manifold

Rows	Swath in Inches		NGP-9055 Application Range in GPA at 5 MPH			
			30 Inch Spacing		36 Inch Spacing	
	30	36	Min	Max	Min	Max
4	120	144	30.1	677.2	25.1	564.3
8	240	288	15.0	338.6	12.5	282.2
12	360	432	10.0	225.7	8.4	188.1
16	480	576	7.5	169.3	6.3	141.1
24	720	864	5.0	112.9	4.2	94.1
36	1080	1296	3.3	75.2	2.8	62.7

All calculations based on ground speed of 5 MPH. Rated Flow Based on 12 lbs. per gallon fertilizer. 316 SS available on wet end casting.



NGP-9055-AR SERIES

Double Piston - Double Acting	Rated Speed - 450 RPM
Stroke - Variable	Inlet - 1 1/2" FPT
Rated Flow - 68.4 GPM total 34.2 GPM per side	Outlet - 1 1/2" FPT
Rated Pressure - 120 PSI	Clutch - No Clutch

- » Apply two products at two rates with one pump
- » Max ratio 5 to 1

Rows	Swath in Inches		NGP-9055-AR Application Range in GPA at 5 MPH			
			30 Inch Spacing		36 Inch Spacing	
	30	36	Min	Max	Min	Max
4	120	144	15.0	338.6	12.5	282.1
8	240	288	7.0	169.3	6.2	141.1
12	360	432	5.0	112.8	4.2	94.0
16	480	576	3.7	84.6	3.1	70.5
24	720	864	2.5	56.4	2.1	47.0
36	1080	1296	1.6	37.6	1.4	31.3

The chart above is for one side of the pump. Calculate first one side of the pump and then calculate the second side.

All calculations based on ground speed of 5 MPH. Rated Flow Based on 12 lbs. per gallon fertilizer. 316 SS available on wet end casting.

PWM CONTROLLED MANIFOLD KITS AND VARIABLE RATE HYDRAULIC DRIVE KITS MAKE PUMPS MORE VERSATILE!



DIRECT MOTOR /PWM MANIFOLD KITS:

- ◀ SHOWN: NGP-6055-HY with 116205-91 (Flow-thru style manifold)
116205-91D (Dead-head style manifold; no hydraulic oil flow through)
 - Draw fluid from remotely-mounted tanks
 - Lower-cost and more compact solution
 - Quick adjustment to application rates
 - Application rates won't change with temperature
 - Incredible suction capability



VARIABLE RATE HYDRAULIC BAR MOUNT RETROFIT KITS:

- ◀ SHOWN: NGP-6055 with VRH-PWM-10
You don't need to buy new equipment to benefit from Variable Rate Technology. A great feature of the John Blue Piston Pump, with the Variable Rate Hydraulic Drive Kit (VRH), is that you can use it on your current equipment - planters, drills, strip tills and liquid applicators - regardless of how old it is!

FIND MORE ON PAGES 21-23 »

NGP Options and Product Compatibility Recommendations*

Part Number (suffix)	Description
-B	Buna wet end o-rings and rod packing, recommended for Aqua Ammonia
-DR**	Independent dual inlet and outlet.
-F	Flanges- cast iron pumps have either 200 or 220 flanges with internal 1" or 1 ½" ports depending on pump models. SS pumps have 220 flanges only.
-K	Pump less sprocket.
-R	RC40 chain 18 tooth sprocket.
-S	316 SS wet-end casting, commonly used on liquid fertilizer pH less than 5
-U	Viton® wet-end o-rings and rod packing, ideal for fumigants and herbicides compatible with Viton® and not compatible with Buna.

Additional Kit Models	Modifies Existing Pumps
115670	Manual clutch add on - NGP universal
115671	Hydraulic clutch add on - NGP universal
115672	Electric clutch add on - NGP universal
115673	Stainless wet-end conversion - NGP-6050 Series
115674	Stainless wet-end conversion - NGP-7050 Series
115675	Stainless wet-end conversion - NGP-8050 Series***
115676	Stainless wet-end conversion - NGP-9055 Series***
116000-01S	1 ½" NPT to 200 series flange adapter, stainless steel
116083-01S	1 ½" NPT to 220 series flange adapter, stainless steel
116123-91	NGP-6055/8055 Direct Drive ASM-Manual Control
116124-91	NGP-7055/9055 Direct Drive ASM-Manual Control
116205-91	Flow-thru Style Hydraulic Motor/PWM Manifold Kit for Direct Drive Piston Pumps
116205-91D	Dead-head Style Hydraulic Motor/PWM Manifold Kit for Direct Drive Piston Pumps
116344-91	Dampener Kit 1 ½" NPT

Repair Kit Models	Details
115788-S	Gasket Repair Kit-For NGP-6050-S
115788-U	Gasket Repair Kit-For NGP-6050-U
115688-S	Gasket Repair Kit-For NGP-7050-S
115688-U	Gasket Repair Kit-For NGP-7050-U
115789-S	Gasket Repair Kit-For NGP-8055-S
115789-U	Gasket Repair Kit-For NGP-8055-U
115689-AR	Gasket Repair Kit-For NGP-9055-AR
115689-DR	Gasket Repair Kit-For NGP-9055-DR
115689-S	Gasket Repair Kit-For NGP-9050-S
115689-U	Gasket Repair Kit-For NGP-9050-U

Repair Kit Models	Details
116134	Gasket Repair Kit - For NGP-4055F
116135	Gasket Repair Kit - For NGP-5055DRF
115788	Gasket Repair Kit - For NGP-6050
115688	Gasket Repair Kit - For NGP-7050
115789	Gasket Repair Kit - For NGP-8050
115789-AR	Gasket Repair Kit - For NGP-8055-AR
115789-DR	Gasket Repair Kit - For NGP-8055-DR
116135-AR56	Gasket Repair Kit - For NGP-5655-ARF
115689	Gasket Repair Kit - For NGP-9050
116457	Gasket Repair Kit - For NGP-4055-HY
116458	Gasket Repair Kit - For NGP-6055-HY
116459	Gasket Repair Kit - For NGP-7055-HY
116460	Gasket Repair Kit - For NGP-9055-HY

* Not available on all models

** -DR only available on double piston pumps: NGP-8050 and NGP-9050.

*** -DR pumps may use 2 single piston stainless conversion kits.

MAKE YOUR FERTILIZER AND CHEMICAL APPLICATIONS SIMPLE: JOHN BLUE COMPANY GROUND DRIVES (DRV)

The John Blue Family of Universal Drive Assemblies-DRV's make the installation of ground driven pumps on applicators and planters simple. Piston pumps have proven they are the most reliable and accurate method of applying liquid fertilizer without exception—bolt it up quickly and easily!

The John Blue Ground Drives (DRV's) make the installation of the best easier with standard sprockets and mountings that fit most applicators and planters to provide the application rates you require.

The piston-metering pump is the standard for accuracy due to the positive displacement ground driven design, which maintains a constant rate per acre as the ground speed varies.

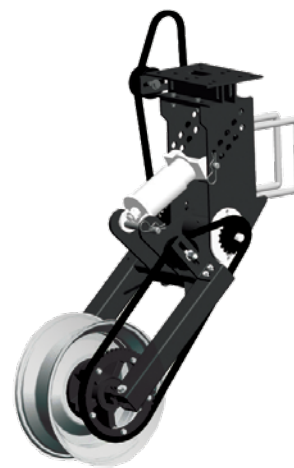
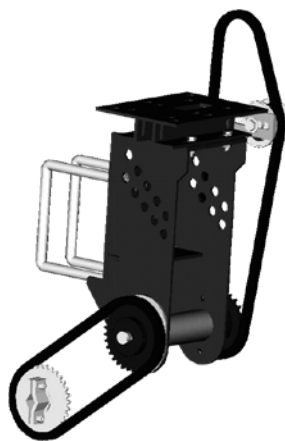
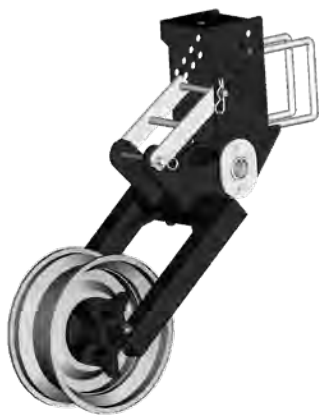
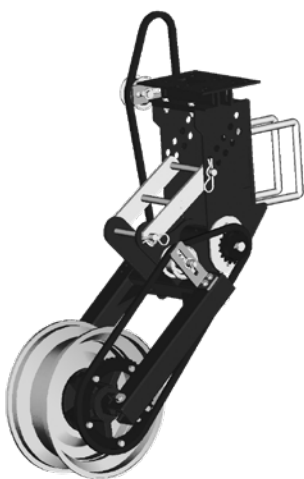

DRV-3000

- Ground Drive with pump mount
- Fixed-height adjustment mechanism (10 positions)
- Less tire and u-bolts

DRV-3100

- Gauge Wheel only
- Fixed-height adjustment mechanism (10 positions)
- Less tire and u-bolts

DRV-3200

- Universal Mount - Pump mount and jackshaft
- For planter hex shaft drive applications
- Less u-bolts

DRV-3300

- Ground Drive with pump mount
- Spring-loaded adjustment mechanism
- Less tire and u-bolts

Pump Drives

Part Number	Description
DRV-3000	Ground Drive with pump mount - fixed height adjustment mechanism (10 positions).
DRV-3050	Squeeze Pump Ground Drive - fixed height adjustment mechanism (10 positions).
DRV-3100	Gauge Wheel only - fixed height adjustment mechanism (10 positions).
DRV-3200	Universal Mount-Pump mount and jackshaft for planter hex shaft drive applications.
DRV-3250	Squeeze Pump Universal Mount includes split sprocket to drive off the planter shaft (no wheel).
DRV-3300	Ground Drive with pump mount - spring loaded adjustment mechanism.
DRV-3350	Squeeze Pump Ground Drive - spring loaded adjustment mechanism.
DRV-SQZ	Drive Adapter Kit for Squeeze Pump.

Add -S after any part number for stainless steel chain option.



DRV

- High and low range sprocket setup for a broader application range.
- Push or pull
- Fits all current John Blue Piston Pumps.
- Fits 7"x7", 6"x6", 4"x6" and 4"x4" bars.
- Universal adjustable idlers: push or pull
- Interchangeable jackshaft sprockets: RC50 24 and 18 Tooth for low and high ranges.
- Ground wheel sprocket: RC50 50 tooth.
- Pump mounting bolts, nuts and washers included.
- Adjustable to fit your bar height: bottom of bar to ground using 13.5" loaded radius tire - Minimum 17", Maximum 31".
- Wide pivot angle: bottom of bar to axle centerline - Minimum 3.5", Maximum 17.5".

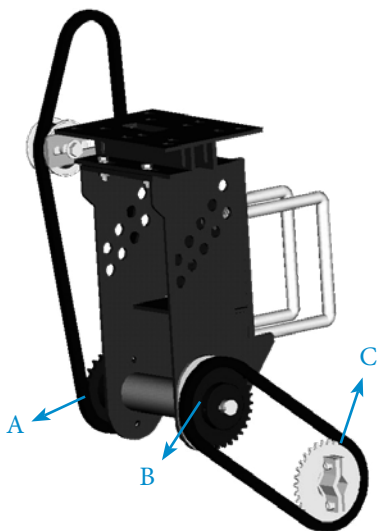

UNIVERSAL PLANTER KIT

- Standard jackshaft with sprockets.
- Fits all current John Blue Piston Pumps.
- Fits 7"x7", 6"x6", 4"x6" and 4"x4" bars.
- U-bolts and washers standard sized. (*sold separately*)
- Standard sprockets - see drawing on left:
 - Pump Sprocket = NGP standard RC50-18 Tooth
 - Sprocket A = RC50-24 Tooth
 - Sprocket B = RC40-32 Tooth
 - Sprocket C = RC40-32 Tooth Split

U-BOLTS FOR DRV UNITS

(2 u-bolts required per drive):

- 7" x 7" Bar part number: 115907-01A
- 4" x 4" Bar part number: 115907-01B
- 4" x 6" Bar part number: 115907-01C
- 6" x 6" Bar part number: 115907-01D

Sprockets available on page 86 »

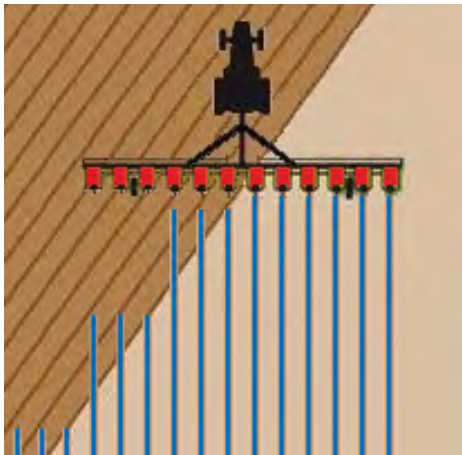

SECTIONAL SHUT-OFF AND VARIABLE RATE ARE EASY WITH THE JOHN BLUE SYSTEM.



VARIABLE RATE HYDRAULIC DRIVE KITS:

- Base Kit to add variable rate capacity to a Next Generation Piston Pump for your planter or applicator. Other required off-the-shelf components to complete the kit are detailed in the instructions.
- Existing pumps can be easily converted to variable rate and sectional shut-off.
- A piston pump allows for quick and stable adjustment to application rates within a fraction of a second using this technology.
- With a piston pump your application rates will not change with the temperature or lack of head pressure.
- Sturdy mounting bracket attaches to the side or top of the machine's bar.
- Two types of flow control valves (servo or PWM) are available based on the kit you select.
- Hydraulic 2-way bypass valve turns pump and liquid flow on and off (only on John Deere® kits).
- Hydraulic motor requires 10 GPM to run the piston pump at maximum RPM, but the system can be used at lower GPM as the specific application allows.
- The manual speed drive system allows you to mount your pump anywhere on the machine and set the pump at a constant speed.
- The manual speed drive can also be used with other brands of hydraulic flow control valves in order to interface with controllers that are not listed below.
- "Bracket only kits" allow the use of the 20/20 Precision Planting® motor, Dickey-john® motor and others.
- Pulsation Dampener for Smooth Flow Down to 40 RPM (Part# 116344-91)

DIRECT HYDRAULIC DRIVE FOR PISTON PUMPS

- Lower cost and more compact solution for variable rate piston pump drives
- Users can supply their own SAE A 2-bolt motor or purchase a Hydraulic Motor/PWM Manifold Kit from John Blue: 116205-91 (Flow-thru style manifold) and 116205-91D (Dead-head style manifold).
- Available for the following piston pumps: NGP-4055-HYF, NGP-6055-HY, NGP-6055-HYF, NGP-7055-HY, NGP-7055-HYF, and NGP-9055-HY.

VRH-JD-10 AND VRH-JD-15

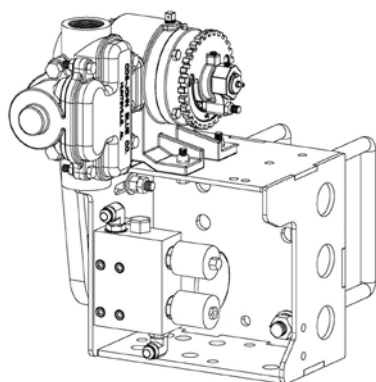

VRH-JD-10

VARIABLE RATE HYDRAULIC DRIVE KIT FOR JOHN DEERE® CANBUS PLANTERS USING GREENSTAR™ GS2 AND GS3.

Kit includes: bar mounting bracket, chain, sprockets, hydraulic motor, PWM flow control manifold, custom adaptor harness and setup instructions with parts listing for obtaining off-the-shelf components to complete installation. Other applications may work, but CANbus wiring must be present.

VRH-JD-15

MULTI-SECTION VARIABLE RATE HYDRAULIC DRIVE KIT FOR JOHN DEERE® CANBUS PLANTERS USING GREENSTAR™ GS2 AND GS3.

Same as above except for harness to control up to 7 section valves. Other applications may work, but CANbus wiring must be present.

VRH-MAN-10

MANUAL RATE/SPEED CONTROL DRIVE KIT FOR REMOTE MOUNTING OF DRIVE.

Kit includes: bar mounting bracket, chain, sprockets, ½" FPT port motor, ½" FPT manually adjusted in-line flow control valve, optical tachometer (to set pump speed) and setup instructions.

VRH-PWM-10



VRH-PWM-10

VARIABLE RATE HYDRAULIC DRIVE KIT FOR RAVEN, AG LEADER®, TRIMBLE® AND OTHER SYSTEMS THAT CAN CONTROL A PWM VALVE.

Motor has manifold with PWM valve and **Raven**-type plug. Kit includes: bar mounting bracket, chain, sprockets, hydraulic motor, PWM flow control manifold and setup instructions.

116133-91

BRACKET-ONLY DRIVE KIT FOR USE WITH 20/20 PRECISION PLANTING, DICKEY-JOHN® AND MICRO-TRAK® DRIVE MOTORS.

Kit includes: bar mounting bracket (no motor), chain, sprockets and setup instructions.

116045-91

UNIVERSAL DRIVE KIT FOR USE WITH ANY HYDRAULIC FLOW CONTROL VALVE.

Motor has ½" female pipe ports for connection to your valve. Kit includes: bar mounting bracket, ½" FPT port motor (no-flow control valve), chain, sprockets and setup instructions.

U-BOLTS FOR YOUR BAR SIZE

(two each required per drive):

- 7"x 7" Bar = 115907-01A
- 4"x 4" Bar = 115907-01B
- 4"x 6" Bar = 115907-01C
- 6"x 6" Bar = 115907-01D

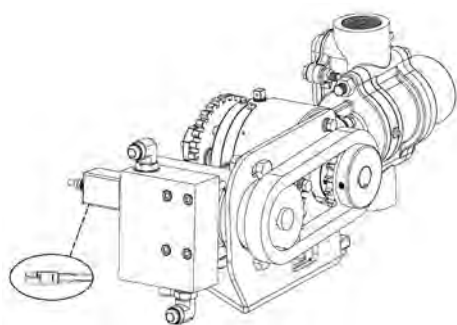

VRH-PWM-15 AND VRH-PWM-17

VRH-PWM-15

VARIABLE RATE HYDRAULIC DRIVE KIT FOR RAVEN, AG LEADER®, TRIMBLE® AND OTHER SYSTEMS THAT CAN CONTROL A PWM VALVE.

Motor has manifold with PWM valve and Raven-type plug.
Kit includes: mounting bracket for NGP-4055-F, 5055-DRF, 6055 and 8055 pumps, chain, sprockets, hydraulic motor, PWM flow control manifold and setup instructions.

VRH-PWM-17

Same as above except with bracket to fit NGP-7055 and NGP-9055.

116131-91

BRACKET-ONLY DRIVE KIT FOR USE WITH 20/20 PRECISION PLANTING, DICKEY-JOHN® AND MICRO-TRAK® DRIVE MOTORS.

Kit includes: mounting bracket for NGP-4055-F, 5055-DRF, 6055 and 8055 pumps (no motor), chain, sprockets and setup instructions.

116132-91

Same as above except with bracket to fit NGP-7055 and NGP-9055.

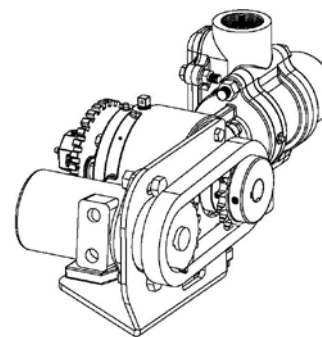

VRH-MAN-15 AND VRH-MAN-17

VRH-MAN-15

MANUAL RATE/SPEED CONTROL DRIVE KIT FOR REMOTE MOUNTING OF DRIVE.

Kit includes: mounting bracket for NGP-4055-F, 5055-DRF, 6055 and 8055 pumps, chain, sprockets, ½" FPT port motor, manually adjusted in-line flow control valve, optical tachometer (to set pump speed) and setup instructions.

VRH-MAN-17

Same as above except with bracket to fit NGP-7055 and NGP-9055.

116123-91

UNIVERSAL DRIVE KIT FOR USE WITH ANY HYDRAULIC FLOW CONTROL VALVE. MOTOR HAS ½" FEMALE PIPE PORTS FOR CONNECTION TO YOUR VALVE.

Kit includes: mounting bracket for NGP-4055-F, 5055-DRF, 6055 and 8055 pumps, ½" FPT port motor (no-flow control valve), chain, sprockets and setup instructions.

116124-91

Same as above except with bracket to fit NGP-7055 and NGP-9055.

Note: The 6055/8055 bracket will not fit NGP-5655-ARF and NGP-8055-AR. You must purchase a bar mount kit.

FEATURES OF THE FLOW DIVIDER

302 SS balanced spring offers superior performance and corrosion resistance.

Exclusive Viton® lip seal is more stable and has a longer life than conventional diaphragms.

316 SS sleeve can be easily removed for cleaning in the field. Alignment pin ensures that the sleeve will be replaced in exactly the same position every time.

Viton® o-rings are used for positive sealing for even hard to handle products.

Numbered ports for ease of tracing lines.

Company name and phone number engraved in part for better in-field serviceability (not pictured)

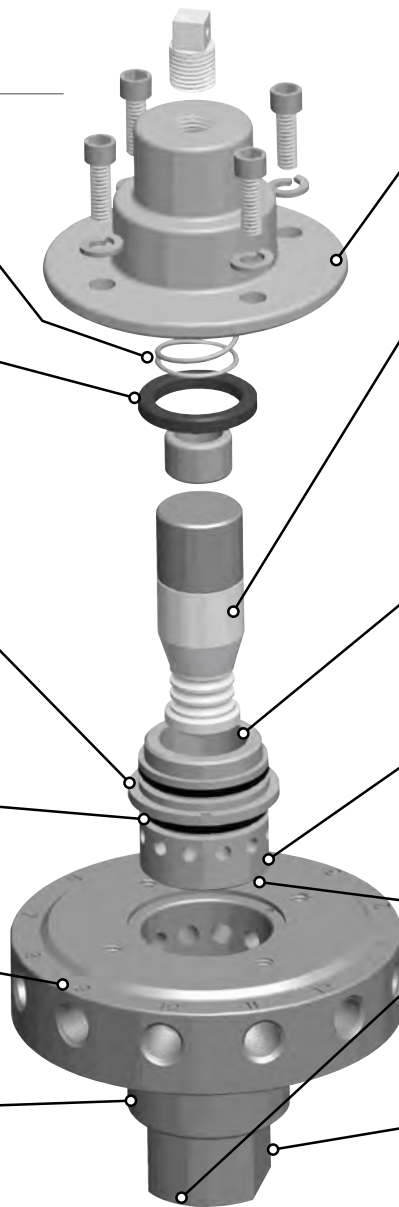

Field repairable without removing distribution lines.

Upper portion of needle is 316 SS, which means longer seal life. The special glass-filled Teflon™ middle needle offers smooth operation with minimum friction. Spherical designed needle tip has better impact resistance.

Spherical tip allows needle to open easier increasing accuracy at lower application rates.

Shorter sleeve increases volume in chamber, reducing operating pressures.

Tapered inlets reduce turbulence resulting in smoother flow and improving accuracy.

Added wrench flats for ease of installation.

Flow Divider and Flow Divider Mount

Part Number	Description	Outlets	Inlet	Outlet	Maximum Flow Per Outlet
FD-0610	Stainless Steel Flow Divider	6	¾" FPT	¼" FPT	2.25 GPM
FD-1210	Stainless Steel Flow Divider	12	¾" FPT	¼" FPT	2.25 GPM
FD-2010	Stainless Steel Flow Divider	20	1" FPT	¼" FPT	2.25 GPM
113989	Manifold Mount				

FLOW DIVIDER ADJUSTABLE SPRING KIT



FEATURES:

- Adjustable spring kit will enable you to balance multiple flow dividers.
- Kit may be purchased separately or pre-installed on any size flow divider.
- When using multiple flow dividers the same size flow dividers must be used.
- With multiple flow dividers the number of plugged outlets should be identical and the plugs equally spaced. The maximum recommended differential between flow dividers is two plugged ports.

Flow Divider Adjustable Spring Kits

Part Number	Description
FD-0610-ADJ	6 Outlet Stainless Steel Flow Divider with Adjustable Spring Kit
FD-1210-ADJ	12 Outlet Stainless Steel Flow Divider with Adjustable Spring Kit
FD-2010-ADJ	20 Outlet Stainless Steel Flow Divider with Adjustable Spring Kit
116063*	FD-0610 Retrofit Kit
116064*	FD-1210 Retrofit Kit
116065*	FD-2010 Retrofit Kit

*Kit will include the adjustment bolt, nut, spring seat, and vented plug.

DELIVERY LINE CHECK VALVES AND PUSH CONNECT FITTINGS

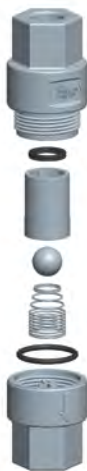

Easy to Clean	Precision molded in glass-reinforced polypropylene
Repairable	316 stainless steel ball and spring
Easier to service in the field	All Viton® seals
Available in 1, 3 and 10 PSI	Max pressure: 125 PSI

Flow Rates vs Pressure	
Inlet Pressure	Flow
5 PSI	1.25 GPM
15 PSI	2.65 GPM
29 PSI	4.00 GPM

*Test used anti-freeze and CV-1101 with 3/8" hose barbs at 70°F.



Poly Applicator Check Valves

Description	1 PSI Part Numbers	3 PSI Part Numbers
Poly Check Valve, 1/4" NPT Female Inlet and Outlet	CV-1101	CV-1103
Poly Check Valve, 1/4" Push Connect Inlet and Outlet	CV-1101-P14	CV-1103-P14
Poly Check Valve, 5/16" Push Connect Inlet and Outlet	CV-1101-P56	CV-1103-P56
Poly Check Valve, 3/8" Push Connect Inlet and Outlet	CV-1101-P38	CV-1103-P38
Poly Check Valve, 1/4" Hose Barbs Inlet and Outlet	CV-1101-B14	CV-1103-B14
Poly Check Valve, 3/8" Hose Barbs Inlet and Outlet	CV-1101-B38	CV-1103-B38
Poly Check Valve, 1/2" Hose Barbs Inlet and Outlet	CV-1101-B12	CV-1103-B12

*Optional inlet/outlet configurations available.

VISAGAGE II

LIQUID FLOW MONITORS



SMPT-OSA4 with SMSS4

PROPER APPLICATION = INCREASED YIELDS

- With the John Blue VisaGage II you will know immediately if an outlet is plugged, thus causing possible variations in your application rates.
- So easy! See the balls in line and know your rate is uniform.
- When the ball is lower you know there is a restriction at the outlet, hose or opener supplied by that flow monitor.
- A ball higher than the others is an indication that hoses or fittings supplied by that specific flow monitor is broken or has a leak.
- Standard Liquid VisaGage Units are manufactured with chemical resistant polypropylene adapters, Viton® o-rings and clear PVC bodies with an additive for UV protection.

CUSTOMIZE YOUR VISUAL FLOW MONITOR SYSTEM

- Get the exact number of flow monitors for spraying or fertilizer applications by simply banking single columns or sets of 4 Flow Monitors or any combination you choose. Clasp them together with the stainless steel clips and Viton® O-rings and go.
- The VisaGage II allows the use of common stainless steel orifice plates.
- Ports are standard NPT. Use our barb or convenient push connect fittings for simple installation.
- Most parts are interchangeable with other brands.

VISAGAGE ORIFICE SELECTOR

- Turn your John Blue VisaGage II into a self-contained orifice changing system.
- This patented system is the first of its kind on the market today.
- Simply select from one of four orifice settings on each disc. Four discs provide for sixteen different options.
- No more getting wet from fertilizers or chemicals when changing orifices.
- Adjustment is quick, no need to travel to each row unit and work with plumbing near the ground.
- PATENT #9433144

VisaGage Orifice Selector*	
Part Number	Description
SMPT-OSA1	Single orifice selector kit.
SMPT-OSA4	Set of 4 orifice selector kit.

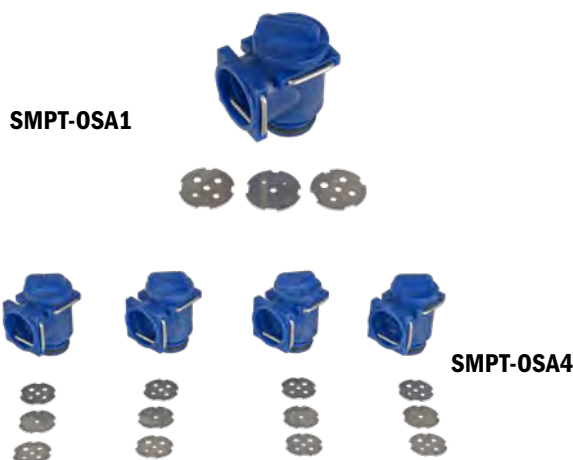



For Use with Sprayers

Part Number*	Description
SMSS1	Single Flow Monitor Assembly - Spray Type includes single body, 3/8" NPT female inlet and outlet, (5) 1/2" diameter balls, end cap, Viton® O-rings and stainless steel retainer clips.
SMSS4	Set of 4 Flow Monitor Assembly - Spray Type includes 4 bodies, 1/2" NPT female inlet, 3/8" NPT female outlet, (20) 1/2" diameter balls, end cap, Viton® O-rings and stainless steel retainer clips.
SMSS1-PE14	Spray Single - 1/4 Elbow Push out, NPT in
SMSS1-PE38	Spray Single - 3/8 Elbow Push out, NPT in
SMSS1-PE56	Spray Single - 5/16 Elbow Push out, NPT in
SMSS4-PE14	Spray Set 4 - 1/4 Elbow Push out, NPT in
SMSS4-PE38	Spray Set 4 - 3/8 Elbow Push out, NPT in
SMSS4-PE56	Spray Set 4 - 5/16 Elbow Push out, NPT in

For Use with Flow Dividers or Squeeze Tube Pumps

Part Number*	Description
SMFD1	Single Flow Monitor Assembly - Flow Divider Type includes single flow divider monitor body, 3/8" NPT female inlet and outlet, (5) 1/2" diameter balls, end cap, Viton® O-rings and stainless steel retainer clips.
SMFD4	Set of 4 Flow Monitor Assembly - Flow Divider Type includes 4 bodies, 3/8" NPT female inlet and outlet, (20) 1/2" diameter balls, end cap, Viton® O-rings and stainless steel retainer clips.
SMFD1-PE14	FD Single - Elbow 1/4 Push in/Out
SMFD1-PE38	FD Single - Elbow 3/8 Push in/Out
SMFD1-PE56	FD Single - Elbow 5/16 Push in/Out
SMFD4-PE14	FD Set of 4 - Elbow 1/4 Push in/Out
SMFD4-PE38	FD Set of 4 - Elbow 3/8 Push in/Out
SMFD4-PE56	FD Set of 4 - Elbow 5/16 Push In/Out

Miscellaneous Components

Part Number	Description
SMPT-0007	O-ring
SMPT-0009	Ball storage unit - optional - holds up to 40 balls (use one per set of 8 bodies). Lid can be locked.
SMPT-0014	Tee - optional - for spray type use with typically 8 total bodies, 1" NPT female inlet port and 1/4" female NPT port for gauge.
SMPT-0021	7/16" Stainless Steel Ball - optional - for use with extra high flow rates.
SMPT-0034	#112 Viton® O-ring - optional - used to seal orifice plates, install plate in recess of the 3/8" NPT port adapters and then install the O-ring to retain and seal orifice plate.
SMPT-0049	Flanged Tee - optional - for spray type use with typically 8 total bodies, 100 series flange with o-rings and 1/4" female NPT port for gauge.
SMPT-0050	Yellow Ball - optional - 13% heavier than the blue plastic ball and lighter than the glass ball that comes standard with the VisaGage II.
SMPT-0051	1/4" Tube Push Connect Elbow Adapter, use existing VisaGage o-ring.
SMPT-0052	5/16" Tube Push Connect Elbow Adapter, use existing VisaGage o-ring.
SMPT-0053	3/8" Tube Push Connect Elbow Adapter, use existing VisaGage o-ring.
SMPT-0061	1/2" NPT End Cap Adapter



LIQUID BLOCKAGE MONITOR SYSTEM

LIQUID BLOCKAGE MONITOR SYSTEM (LBMS)

DETECTS LOW-FLOW AND BLOCKED LINES FOR BOTH LIQUID FERTILIZER AND NH₃.



Now you can know your liquid and NH₃ application flow from the cab of your tractor.



NEW LBMS ENHANCEMENTS

NEW AND IMPROVED FEATURES FOR LIQUID BLOCKAGE MONITOR SYSTEM!

Improved interface visibility

Improved row blockage visibility

“NEW” GPS coordinates will be logged at the time of blockage if tablet has GPS capability

Smoother flow rate transitions

Easy to read sensor settings

User-friendly tool pane

Durable Construction

“NEW” calibration log for more detailed record keeping



FEATURES OF LBMS:

- Magnetic sensing technology mounted behind Liquid or NH₃ VisaGage II Flow Monitors.
- Can be mounted to existing liquid VisaGage II units, new magnetic balls are supplied.
- Identifies where magnetic balls are floating in each row during application.
- Shows both low and no-flow, plus premium systems show high flow for broken lines.
- See a visual display and hear an audible alarm on the control panel from your tractor cab. Can be used with cloudy or dark liquids and NH₃, LED is visible to the sides of the columns.
- Each row with a problem, will be highlighted by a flashing LED light at the row. No need to remember or search for the blocked row when you come to a stop.
- Alarm will reset automatically when the blockage has been corrected.
- Can “Pause” the system to capture problem rows for investigation later when you are able to stop.
- Our patented LBMS is available in five user-friendly options: standard wired control panel, iPad, Android or Amazon Kindle wireless system, and ISOBUS.
- LBMS app is free and available from Apple App Store, Google Play, and Amazon.
- Wireless apps and ISOBUS sections can be defined and rows can be numbered.

VISAGAGE II UNITS ARE AVAILABLE ON PAGE 26-27 FOR LIQUID AND PAGE 73 FOR NH₃/ANHYDROUS AMMONIA.

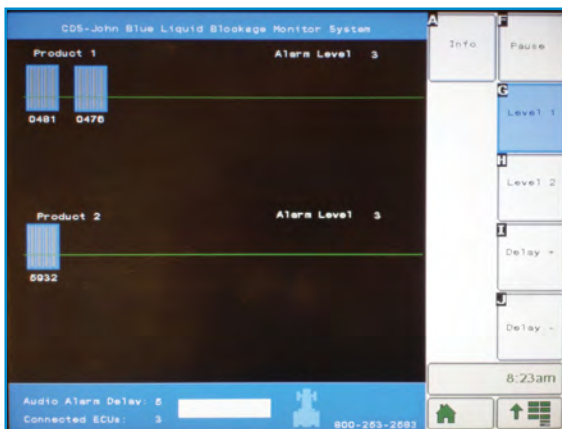

ISOBUS Compatible LBMS*	
Part Number	Description
BM-08ISO (Universal Kit)	ISOBUS 8 Row Kit Includes: A. Main Computer Harness B. Job Computer C. Tap Harness -universal or brand-specific (i.e. John Deere®) D. Tee harness E. Two - 15 ft. Extension Harness F. Two Standard Sensor Kits G. Two Terminator Plugs. For use with GS2/GS3 only.
BM-08ISO-JD (John Deere® Kit)	
BMPT-001	4 Row Sensor Expansion Kit for adding to BM-08ISO and BM-08ISO-JD - includes standard sensor, tee harness, 12 magnetic balls & hardware.
BMPT-036	Universal ISOBUS for converting from BMi-08 to ISOBUS.
BMPT-036-JD	John Deere® ISOBUS for converting from BMi-08 to ISOBUS. For use with GS2/GS3 only.

NOTE: Liquid VisaGage II Flow Monitors are ordered separately: SMSS4 set of 4 Flow Monitor Spray Type and SMFD4 set of 4 Flow Monitor Divider Type, see page 26-27. NH₃ VisaGage II ordered separately: SMFD2-NH₃ (2 row) and SMFD4-NH₃ (4 row), see pg. 72.

Notice of Operation:
 Be aware a minimum of 0.126 gallons per minute per row based on 11lb./gallon liquid fertilizer is required in order monitor flow of product successfully. Less than 0.126 gallons per minute per row based on 11lb./gallon of liquid fertilizer is not recommended by the John Blue Company in order to effectively monitor flow using a Liquid Blockage Monitor System.

HOW TO ORDER:

1. Purchase an ISOBUS 8 Row Liquid Blockage Monitor Kit, #BM-08ISO(-xx):

Components Included in BM-08ISO, BM-08ISO-JD, etc.:

- Main Computer Harness
- Job Computer
- Tap Harness (universal or brand-specific (i.e. Deere)
- Tee Harness
- 15ft Extension harness (qty = 2)
- Standard Sensor Kit (qty = 2)
(includes standard sensor, tee harness, 12 magnet balls, & hardware)
- Terminator Plug (qty = 2)

2. If the harness lengths supplied are not long enough for your machine measurements, you can order more of these harnesses and add them anywhere in the circuit:

- **BMPT-012:** 28FT Extension harness
- **BMPT-013:** 15FT Extension harness
- **BMPT-014:** 7FT Extension harness

3. Purchase the required number of 4-Row Sensor Expansion Kits (#BMPT-001) to cover the number of rows on your machine (extra rows are ok). The location of the individual sensors does not matter, and they do not have to be evenly split.

4. Order the required number of Visagage II assemblies for your machine, and at installation you will replace the standard balls with the appropriate magnet ball for your specific row flow rate.

5. Verify that your virtual terminal has the correct software in order to run ISOBUS programs.

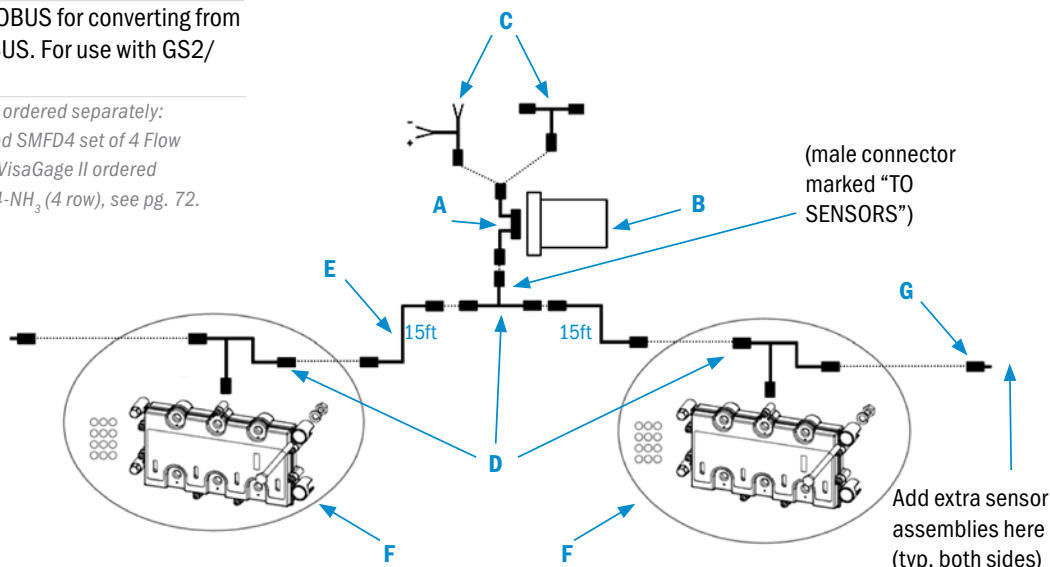

PREMIUM LBMS SYSTEM



NEW LBMS ENHANCEMENTS
 New and improved features for Liquid Blockage Monitor System (LBMS)!
 See Page.....28

INSTALLATION OPTIONS FOR SMSS STYLE VISAGAGE II FLOW MONITORS

EXAMPLE OF TRADITIONAL "GROUPED" VISAGAGES

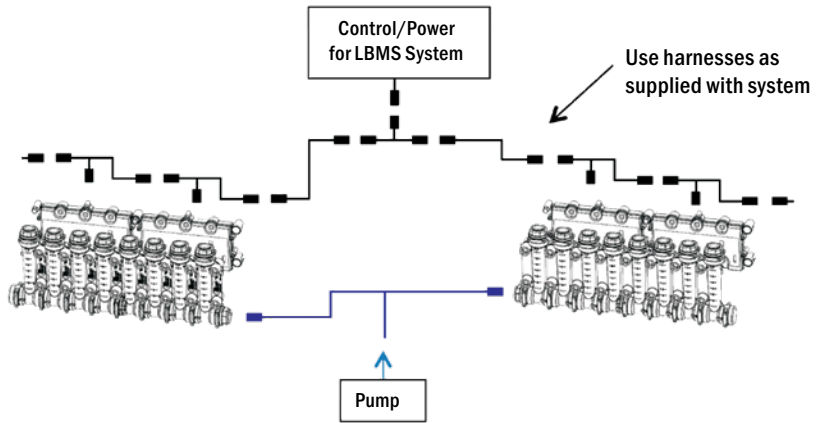

EXAMPLE OF OPTIONAL "SPACED" SETS OF VISAGAGES: FOR USE WITH A LOG TYPE MANIFOLD SYSTEM OR WHEN A SHORTER LINE LENGTH TO EACH ROW IS DESIRED

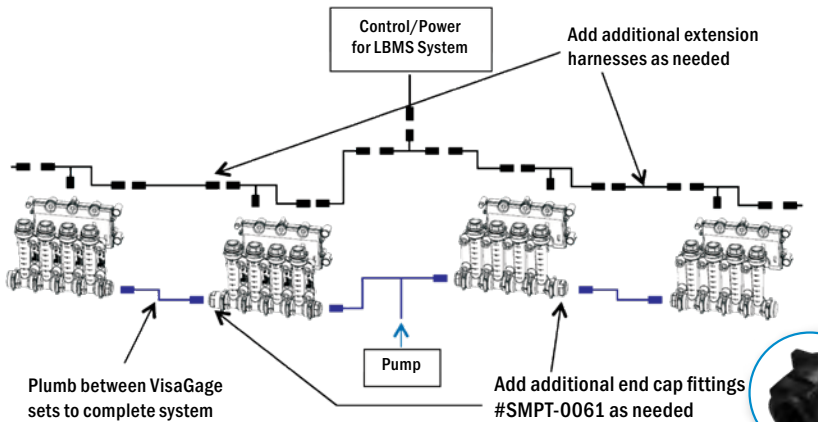

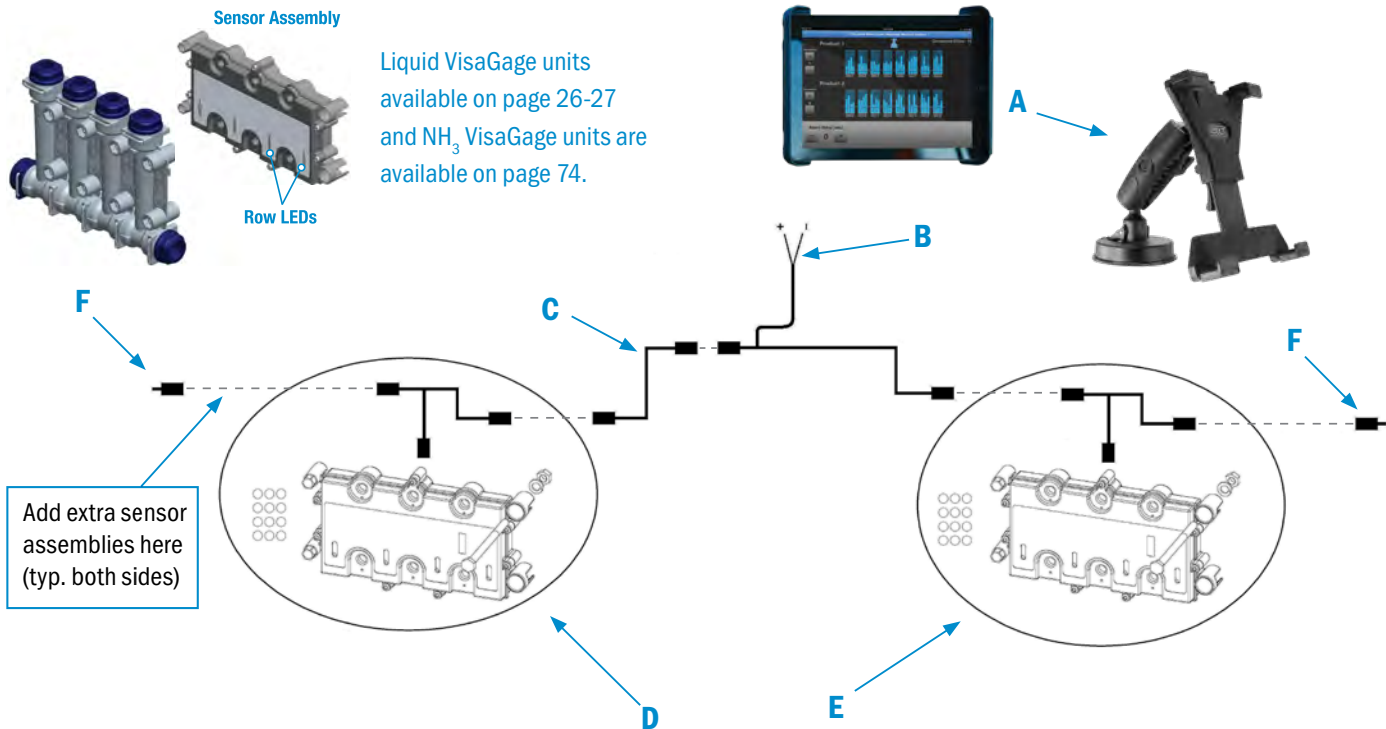

Liquid VisaGage units available on page 26-27 and NH₃ VisaGage units are available on page 74.

Add extra sensor assemblies here (typ. both sides)



The LBMS app is free and available from the Apple App store, Google Play, and Amazon.

HOW TO ORDER:

1. Purchase a Premium 8 Row Blockage Monitor Kit, #BMI-08
2. If the harness lengths supplied are not long enough for your machine measurements, additional harnesses can be ordered and added anywhere in the circuit:
 - BMPT-012: 28FT Extension harness
 - BMPT-013: 15FT Extension harness
 - BMPT-014: 7FT Extension harness
3. Purchase the required number of 4-Row Sensor Expansion Kits (#BMPT-001, item E) to cover the number of rows on your machine (extra rows are ok). The location of the individual sensors does not matter and they do not have to be evenly split.
4. Order the required number of VisaGage II assemblies for your machine. At installation replace the standard balls with the appropriate magnet ball for your specific row flow rate for liquid only. NH₃ VisaGage units come standard with magnetic balls.
5. Purchase an iPad 2 or newer display running the latest iOS or a quality 7" or larger Android tablet running at least Android 4.0.

Premium System*	
Part Number	Description
BMI-08	Premium 8 Row Kit Includes: A. iPad mounting bracket B. Input harness C. 28 ft. extension harness D. Wireless sensor kit E. Standard sensor kit F. Two terminator plugs
BMPT-001	4 Row Sensor Expansion Kit for adding to BMI-08 Includes: standard sensor, tee harness, magnet balls and hardware.

*Liquid VisaGage II Flow Monitors are ordered separately: SMSS4 set of 4 Flow Monitor Spray Type and SMFD4 set of 4 Flow Monitor Divider Type, see page 26-27. NH₃ VisaGage II ordered separately: SMFD2-NH₃ (2 row) and SMFD4-NH₃ (4 row), see page 74.

Notice of Operation:

Be aware a minimum of 0.126 gallons per minute per row based on 11lb./gallon liquid fertilizer is required in order monitor flow of product successfully. Less than 0.126 gallons per minute per row based on 11lb./gallon of liquid fertilizer is not recommended by the John Blue Company in order to effectively monitor flow using a Liquid Blockage Monitor System.

STANDARD LBMS SYSTEM

STANDARD CONTROL PANEL (WIRED)*

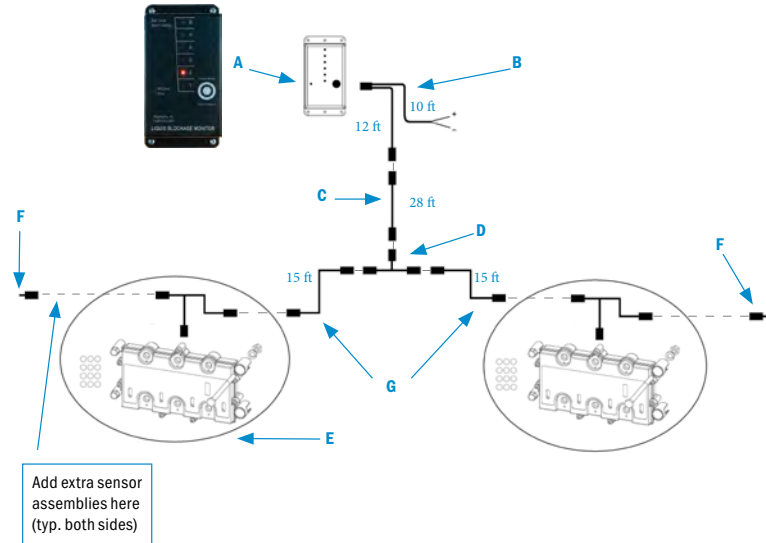
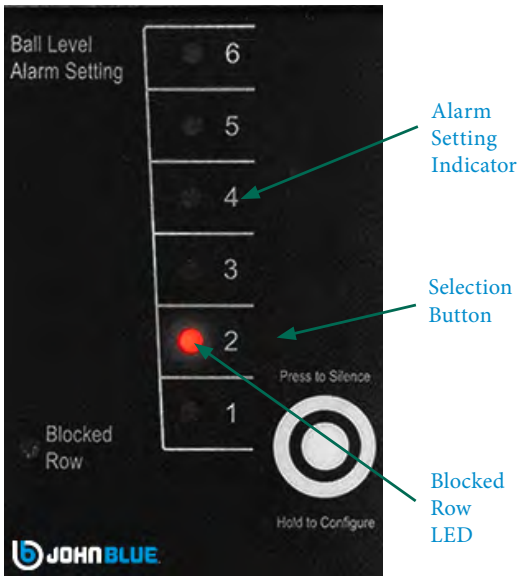

HOW TO ORDER:

1. Purchase one of the Standard 8 Row Blockage Monitor Kits, BM-08AP or BM-08PL, which differ by item(s) "G". See the following:
2. If the harness lengths supplied are not long enough for your machine measurements, additional harnesses can be ordered and added anywhere in the circuit:
 - **BMPT-012:** 28FT Extension harness
 - **BMPT-013:** 15FT Extension harness
 - **BMPT-014:** 7FT Extension harness
3. Purchase the required number of 4-Row Sensor Expansion Kits (#BMPT-001, item E) to cover the number of rows on your machine (extra rows are ok). The location of the individual sensors does not matter and they do not have to be evenly split.
4. Order the required number of VisaGage II assemblies for your machine. At installation replace the standard balls with the appropriate magnet ball for your specific row flow rate for liquid only. NH₃ VisaGage LMBS come standard with magnetic balls.

Standard Control System *	
Part Number	Description
BM-08AP	Applicator 8 Row Kit Includes: A. Control panel with mount bracket B. Input harness C. 28 ft. extension harness D. Tee harness E. Two standard sensor kits F. Two terminator plugs
BM-08PL	Planter 8 Row Kit Includes: A. Control panel mounting bracket B. Input harness C. 28 ft. extension harness D. Tee harness E. Two standard sensor kits F. Two terminator plugs G. Two 15 ft. extension harnesses
BMPT-001	4-Row Sensor Expansion Kit for adding to BM-08AP and BM-08PL - includes: standard sensor, tee harness, magnet balls and hardware.

*Liquid VisaGage II Flow Monitors are ordered separately: SMSS4 set of 4 Flow Monitor Spray Type and SMFD4 set of 4 Flow Monitor Divider Type, see page 27. NH₃ VisaGage II ordered separately: SMFD2-NH₃ (2 row) and SMFD4-NH₃ (4 row), see page 74.



Liquid VisaGage units are available on page 26-27 and NH₃ VisaGage units are available on page 74.

Notice of Operation:

Be aware a minimum of 0.126 gallons per minute per row based on 11lb./gallon liquid fertilizer is required in order monitor flow of product successfully. Less than 0.126 gallons per minute per row based on 11lb./gallon of liquid fertilizer is not recommended by the John Blue Company in order to effectively monitor flow using a Liquid Blockage Monitor System.

UPDATE YOUR JOHN DEERE® EQUIPMENT WITH THE LATEST TECHNOLOGY FROM JOHN BLUE COMPANY

JOHN BLUE COMPANY HAS DEVELOPED THE FOLLOWING KITS TO MAKE IT EASIER TO USE JOHN BLUE PRODUCTS ON YOUR JOHN DEERE® PLANTER.



Kits for converting the 1770NT John Deere® Port Manifold System to the John Blue Flow Divider (for planters built 2012 and after).

Part Number	Description
116098 (16 row)	Kit includes 16 outlet Flow Divider, (16) 1 PSI Check Valves and all necessary plumbing.
116099 (12 row)	Kit includes 12 outlet Flow Divider, (12) 1 PSI Check Valves and all necessary plumbing.

*VisaGage II's are available, see pages 26-27.

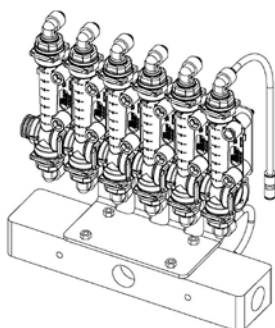

VisaGage II Kits when just adding flow monitors to your 1770NT John Deere® Planter (planters built 2012 and after). Kits will bolt directly to your manifold.

Part Number	Description
116150 (24 row)	Kit includes (6) sets of 4 Flow Monitor Assemblies, backing plate, mounting bracket, tubing and all necessary plumbing.
116107 (16 row)	Kit includes (4) Sets of 4 Flow Monitor Assemblies, backing plates, mounting brackets, tubing and all necessary plumbing.
116108 (12 row)	Kit includes (3) Sets of 4 Flow Monitor Assemblies, backing plates, mounting brackets, tubing and all necessary plumbing.
116151 (8 row)	Kit includes (2) sets of 4 Flow Monitor Assemblies, backing plate, mounting bracket, tubing and all necessary plumbing.



Variable Rate Hydraulic (VRH) Drive Kits for John Deere® Planters

Part Number	Description
VRH-JD-10	VRH Kit for John Deere® CANbus Planters Using GreenStar™ GS2 and GS3. Kit includes: mounting bracket, chain, sprockets, hydraulic motor, PWM flow control manifold, custom adaptor harness and setup instructions with parts listing for obtaining off-the-shelf components to complete installation. Other applications may work, but CANbus wiring must be present.
VRH-JD-15	Multi-Section VRH Drive Kit for John Deere® CANbus Planters using GreenStar™ GS2 and GS3. Kit includes same as above except for harness to control up to 7 section valves. Other applications may work, but CANbus wiring must be present.

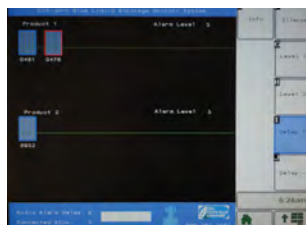

ISOBUS Compatible Liquid Blockage Monitor System (LBMS)

Part Number	Description
BM-08ISO-JD	8 row kit for John Deere® Planters with ISOBUS, splice harness supplied for quick connection. For use with GS2/GS3 only.
BMPT-036-JD	John Deere® ISOBUS for converting from BMi-08 to ISOBUS.

SQUEEZE TUBE PUMPS

OVAL-SHAPED TUBE WITH BUILT-IN BACKING PLATE SQUEEZE TUBE PUMP

Sealed-for-life bearings require no lubrication.

Oval-shaped tubes with built-in backing plate insure accurate rates. The positive shut-off is due to the positive sealing tubes.

Rubber-coated rollers are easily replaced in the field, plus non-metallic roller surfaces reduce abrasion, resist corrosion and etching by fertilizers.

Heavy-duty PVC manifolds are ideal for all fertilizers including acid-based products.

Sturdy, all metal frame.

8B-1

8-48 outlets are available. Outlets can be doubled for higher rates.

Pump shaft lets you drive the unit from either side.

Multiple-coned sprockets come standard allowing for seven different delivery rates.

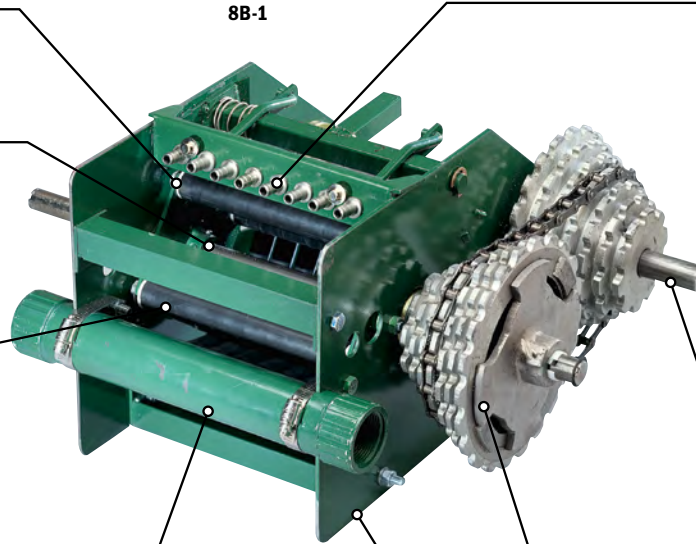

ROUND HOSE WITH PATENTED SPRING LOADED BACK PLATE SQUEEZE TUBE PUMP



Patented spring loaded back plate insures accurate rates.

Positive shut-off when pump stops.

6-16 outlets are available.

Fittings can be relubricated to flush out contamination.

Heavy cast iron frame.

Choice of optional individual sprockets or complete cluster sets.

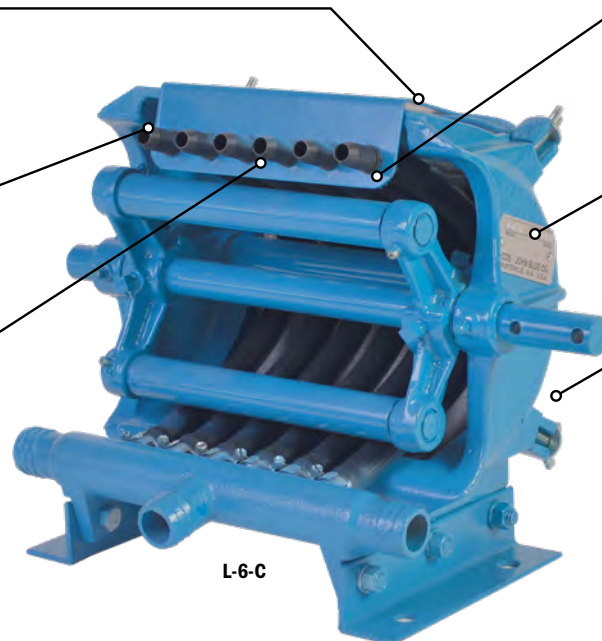

L-6-C

SQUEEZE PUMP SPECIFICATIONS

Hose Size	Maximum Output Per Hose	Maximum Speed	Maximum Pressure	Rate Range GPA
Oval Shaped Tube With Built-in Backing Plate Squeeze Pump				
3/8"	.63 GPM	100	6 PSI	1.5-25*
5/8"	1.26 GPM	100	6 PSI	3-50*
Round Hose Spring Loaded Back Plate Squeeze Pump				
5/16"	.58 GPM	125	6 PSI	3-23**
1/2"	1.4 GPM	125	6 PSI	7-55**

*Maximum GPA rating based on 5 MPH, 30 inch rows. Minimum is based on 24 pulses per minute.

**Maximum rating based on 5 MPH, 30 inch rows. Minimum is based on 48 pulses per minute.

MODELS AVAILABLE FOR OVAL-SHAPED SQUEEZE TUBE PUMP WITH BUILT-IN BACKING PLATE

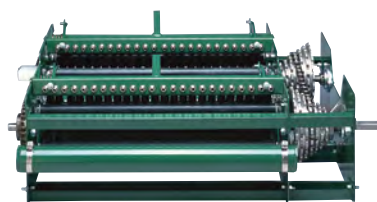
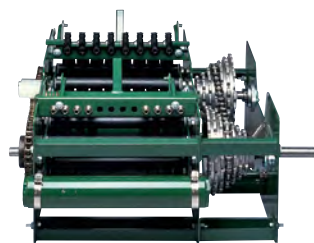
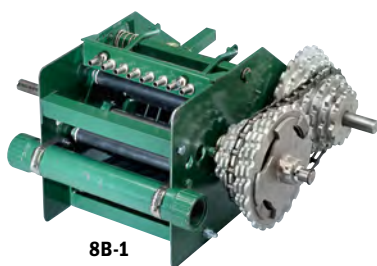

Part Number	Number of Rows	Metering Hose Size	GPA	Discharge Hose Size	Suction Hose Port
Standard Models					
8B-1	8	3/8"	1.5-25	3/8"	1 1/4" FPT
8L	8	5/8"	3-50	1/2"	1 1/4" FPT
12B-1	12	3/8"	1.5-25	3/8"	1 1/4" FPT
12L	12	5/8"	3-50	1/2"	1 1/4" FPT
16B-1	16	3/8"	1.5-25	3/8"	1 1/4" FPT
16L	16	5/8"	3-50	1/2"	1 1/4" FPT
24B-1	24	3/8"	1.5-25	3/8"	1 1/4" FPT
Hydraulic Models					
8B-IH	8	3/8"	1.5-25	3/8"	1 1/4" FPT
8L-H	8	5/8"	3-50	1/2"	1 1/4" FPT
12L-H	12	5/8"	3-50	1/2"	1 1/4" FPT
16L-H	16	5/8"	3-50	1/2"	1 1/4" FPT
Combination Pump Model					
8B-1/8L	16	3/8" & 5/8"	1.5-50	3/8" & 1/2"	1 1/4" FPT
Double Pump Models					
24LD	24	5/8"	3-50	1/2"	1 1/4" FPT
32BD-1	32	3/8"	1.5-25	3/8"	1 1/4" FPT

Note: B-1 Pumps have stainless steel fittings.

L Pumps have plastic fittings.

Combination Pumps have B-1 Pump at front (input drive end).



ROUND HOSE SPRING LOADED BACK PLATE SQUEEZE TUBE PUMP

Standard Models					
Part Number	Number of Rows	Metering Hose Size	GPA	Discharge Hose Size	Suction Hose Size
L-6-C	6	½"	7-55	½"	1"
L-8-C	8	5/16"	3-23	3/8"	1"
L-8-LC	8	½"	7-55	½"	1 ¼"
L-12-SC	12	5/16"	3-23	3/8"	1 ¼"
L-12-C	12	½"	7-55	½"	1 ¼"
L-16-C	16	5/16"	3-23	3/8"	1 ¼"



PUMP DRIVES AND OPTIONAL ACCESSORIES

Standard Models	
Part Number	Description
L-4512	Sprocket Package - Base: includes (2) L-1414 & (2) L-4414; 10T, 15T, 20T, 22T & 26T sprockets.
L-4513	Sprocket Package - Complete: includes L-1414 & L-4414; 8T, 9T, 10T, 15T, 22T, 23T, 26T, 30T & 31T sprockets.
114272	Sprocket Cluster for the round tube squeeze pump containing 10T, 15T, 20T, 22T, 26T sprockets.

Miscellaneous Components			
Part Number	Description	Part Number	Description
111699-02	Hub Adaptor-5 Hole	L-1384	9 Tooth Sprocket
L-1414	Sprocket Adaptor - 7/8" Bore	L-1386	15 Tooth Sprocket
L-1414-1	Sprocket Adaptor - 1" Bore	L-1381	20 Tooth Sprocket
L-1414-2	Sprocket Adaptor - ¾" Bore	L-1387	22 Tooth Sprocket
L-4414	Sprocket Retainer - 7/8" Bore	L-1388	23 Tooth Sprocket
L-4414-1	Sprocket Retainer - 1" Bore	L-1389	26 Tooth Sprocket
L-4414-2	Sprocket Retainer - ¾" Bore	L-1390	30 Tooth Sprocket
112838	Sprocket Retainer - 7/8" Hex	L-1391	31 Tooth Sprocket
112839	Sprocket Adaptor - 7/8" Hex	L-1392	32 Tooth Sprocket
114565-91	35 Tooth Split Sprocket for 7/8" Hex Shaft	114936-91	32 Tooth Split Sprocket for 7/8" Hex Shaft



SEE OUR COMPLETE LINE OF GROUND DRIVES ON PAGES 19-20.

REPAIR PARTS AVAILABLE ON PAGE 81-84.



113983

STAINLESS MANIFOLD FEATURES:

- The John Blue manifold can be used with clear liquids for even distribution when used with proper size orifice.
- Manifolds are constructed of domestic investment cast stainless steel, which will last for many years.
- Heavy duty, cast iron manifolds are also available.

Manifolds and Mounts						
Part Number	Description	Number of Outlets	Rating PSI	Construction	Inlet	Outlet
113983	NH ₃ Manifold w/ Flow Diffuser	12	150	304 SS	1" FPT	¼" FPT
113934	Liquid Manifold	12	250	304 SS	1" FPT	¼" FPT
114015	Liquid Manifold	4	250	304 SS	1 ½" FPT	¾" FPT
114382	Liquid Manifold	16	250	304 SS	1" FPT	¼" FPT
A-1402-L	Liquid Manifold	12	N/A	Cast Iron	¾" FPT	¼" FPT
L-1730	Liquid Manifold	3	N/A	Polyethylene	¾" FPT	¾" FPT
114106	Manifold Mount for 114015	N/A	N/A	N/A	N/A	N/A



113934

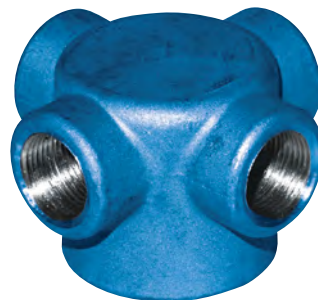

114015



114382

CHECK VALVES AND HOSE BARBS:

Check Valves help prevent backflow, siphoning and bleed-through of product. John Blue offers check valves in both poly and 316 stainless steel. Regardless if you are using an orifice system or the proven flow divider technology, John Blue has an inline check valve that's right for you.

Check Valves - Used with Flow Dividers and Manifolds (More information on pages 24-25)

Description	Part Number	
Stainless steel - 1/4" FPT with nozzle cap	NS-3030	
Stainless Steel - 11/16" Female threads with nozzle cap	NS-3032	
Nylon, in-line - 3/8" hose x 3/8" hose	NS-3035	
Nylon, in-line 1/2" hose x 1/2" hose	113827	

Description*	1 PSI Part Numbers	3 PSI Part Numbers
Poly Check Valve, 1/4" NPT Female Inlet and Outlet	CV-1101	CV-1103
Poly Check Valve, 1/4" Push Connect Inlet and Outlet	CV-1101-P14	CV-1103-P14
Poly Check Valve, 5/16" Push Connect Inlet and Outlet	CV-1101-P56	CV-1103-P56
Poly Check Valve, 3/8" Push Connect Inlet and Outlet	CV-1101-P38	CV-1103-P38
Poly Check Valve, 1/4" Hose Barbs Inlet and Outlet	CV-1101-B14	CV-1103-B14
Poly Check Valve, 3/8" Hose Barbs Inlet and Outlet	CV-1101-B38	CV-1103-B38
Poly Check Valve, 1/2" Hose Barbs Inlet and Outlet	CV-1101-B12	CV-1103-B12

*Optional inlet/outlet configurations available.

Hose Barbs - Used with Flow Dividers and Manifolds

Part Number	Description	MPT Size	Hose Size
A-94	Hose coupling, steel	1/4"	1/4"
A-94-A	Hose coupling	1/4"	3/8"
A-94-AS	Hose coupling, stainless steel	1/4"	3/8"
A-94-S	Hose couple	1/8"	1/4"
A-7786	Hose coupling, steel	1/4"	1/2"
S-2927	Hose coupling, nylon	1/4"	3/8"
T-2207	Hose insert, nylon	1/4"	1/2"





CENTRIFUGAL PUMPS

CENTRIFUGAL PUMPS TRANSFER & SPRAY

John Blue Centrifugal transfer and spray pumps offer exceptional quality for moving hard-to-handle products quickly and efficiently. Built to last and forgiving of dry runs, these pumps provide unmatched peace of mind. The Cast-Iron Centrifugal transfer pumps come with a two-year unconditional warranty, ensuring superior transfer rates, durability, and reliability. Our versatile spray pumps, designed for agricultural and industrial use, are chemical-resistant and suitable for a variety of applications.



2

CENTRIFUGAL PUMPS

Poly-Centrifugal Pumps (PSP).....39-41
Pedestal Mounts40
Pumps for De-icing.....41
Cast Iron Centrifugal Pumps & Engines (SP).....42-45
Spray Pumps.....46-48



POLYPROPYLENE (PSP) CENTRIFUGAL PUMPS



PSP-3240



PATENT-PENDING 2" SELF-PRIMING POLY-CENTRIFUGAL PUMPS

200 GPM Max Flow
 45 PSI Max Pressure
 112 GPM @ 25 PSI
 Max Speed 3600
 Required Horsepower: 5 HP
 2" Inlet & Outlet FPT

Vac-U-Seal Impeller
 Close-coupled Shaft
 Fits 3/4" Diameter Shaft
 Double Wet Seal Assembly
 Chemical Resistant Materials
 1" FPT pressure access & 1/2" FPT drain port



PSP-3340-BSFLG



PATENT-PENDING 3" SELF-PRIMING POLY-CENTRIFUGAL PUMPS

375 GPM Max Flow
 73 PSI Max Pressure
 Max Speed 3600
 Required Horsepower: 10 HP
 3" Inlet & Outlet FPT
 Vac-U-Seal Impeller

Close-coupled Shaft
 Fits 1" and 1-1/8" Diameter Shafts
 Double Wet Seal Assembly
 Chemical Resistant Materials
 1" FPT pressure access & 1/2" FPT drain port

PRODUCT FEATURES

- Fully-assembled from the factory—ready to be attached to power source immediately.
- Double Wet Seal Assembly—pump can be run dry without causing seal failure. The seal is antifreeze cooled. (Antifreeze is pre-filled from the factory.)
- Closed Impeller Technology—pump efficiency improves over time as the impeller wears.
- Polypropylene Body, FKM and Viton® Seals, 316SS Impeller Shaft for excellent chemical resistance.
- Pump can be removed, or engine can be replaced without having to disassemble the pump.



PSP-3240-G5H



PSP-3240-E5T3B



PSP-3340-G13H

PSP - Poly-Centrifugal Models

Part Number	Pump Type
PSP-3240	2" Poly SP Centrifugal, Engine mount
PSP-3240-FLG	2" Poly SP Centrifugal, Engine mount, Flanged Fittings
PSP-3240-E	2" Poly SP Centrifugal, Electric Motor Mount
PSP-3240-EFLG	2" Poly SP Centrifugal, Electric Motor Mount, Flanged Fittings
PSP-3240-G5H	2" Poly SP Centrifugal, with 5 HP Honda GX160 Motor
PSP-3240-G5HFLG	2" Poly SP Centrifugal, with 5 HP Honda GX160 Motor, Flanged Fittings
PSP-3240-G6H	2" Poly SP Centrifugal, with 6 HP Honda GX200 Motor
PSP-3240-G6HFLG	2" Poly SP Centrifugal, with 5 HP Honda GX200 Motor, Flanged Fittings
PSP-3240-E5D1B	2" Poly SP Centrifugal, 5 HP Electric Drip Proof, 1 Phase
PSP-3240-E5D1BFLG	2" Poly SP Centrifugal, 220 Flange Adapters, 5 HP Electric Drip Proof, 1 Phase
PSP-3240-E5D3B	2" Poly SP Centrifugal, 5 HP Electric Drip Proof, 3 Phase
PSP-3240-E5D3BFLG	2" Poly SP Centrifugal, 220 Flange Adapters, 5 HP Electric Drip Proof, 3 Phase
PSP-3240-E5T1B	2" Poly SP Centrifugal, 5 HP Electric TEFC, 1 Phase
PSP-3240-E5T1BFLG	2" Poly SP Centrifugal, 220 Flange Adapters, 5 HP Electric TEFC, 1 Phase
PSP-3240-E5T3B	2" Poly SP Centrifugal, 5 HP Electric TEFC, 3 Phase
PSP-3240-E5T3BFLG	2" Poly SP Centrifugal, 220 Flange Adapters, 5 HP Electric TEFC, 3 Phase
PSP-3240-P	2" Poly SP Centrifugal with Pedestal
PSP-3240-PFLG	2" Poly SP Centrifugal with Pedestal and Flanges
PSP-3240-PH2	2" Poly SP Centrifugal with Hydraulic Motor
PSP-3240-PH2FLG	2" Poly SP Centrifugal with Hydraulic Motor and Flanges
PSP-3240-G6B	2" Poly SP Centrifugal with 6 HP Briggs & Stratton Pro Engine
PSP-3240-G6BFLG	2" Poly SP Centrifugal with 6 HP Briggs & Stratton Pro Engine and Flanges
NEW! PSP-3240-G6HE	2" Poly SP Centrifugal with 6HP Honda GX200 Engine with Electric Start and Base
NEW! PSP-3240-G6HEFLG	2" Poly SP Centrifugal with 6HP Honda GX200 Engine with Electric Start and Base, Flanged Fittings
PSP-3340	3" Poly SP Centrifugal, Engine mount, 1-1/8" Shaft
PSP-3340-BS	3" Poly SP Centrifugal, Engine mount, 1" Shaft, Keyed shaft clamp standard
PSP-3340-E	3" Poly SP Centrifugal, Electric Motor Mount
PSP-3340-BSFLG	3" Poly SP Centrifugal, Engine mount, Keyed shaft clamp standard, and Flanges
PSP-3340-E10TB	3" Poly SP Centrifugal, 10 HP Electric TEFC, 3 Phase
PSP-3340-E10TB-1	3" Poly SP Centrifugal, 10 HP Electric TEFC, 1 Phase
PSP-3340-E10TB-1FLG	3" Poly SP Centrifugal, 10 HP Electric TEFC, 1 Phase, and Flanges
PSP-3340-E10TBFLG	3" Poly SP Centrifugal, 10 HP Electric TEFC, 3 Phase, and Flanges
PSP-3340-EFLG	3" Poly SP Centrifugal, Electric Motor Mount, and Flanges
PSP-3340-G13H	3" Poly SP Centrifugal, 13 HP Honda Gas Electric Start with Base
PSP-3340-G13HFLG	3" Poly SP Centrifugal, 13 HP Honda Gas Electric Start with Base and Flanges
PSP-3340-G14K	3" Poly SP Centrifugal, 14 HP Kohler Gas Electric Start with Base
PSP-3340-G14KFLG	3" Poly SP Centrifugal, 14 HP Kohler Gas Electric Start with Base and Flanges
PSP-3340-G14V	3" Poly SP Centrifugal, 14 HP Vanguard Gas Electric Start with Base
PSP-3340-G14VFLG	3" Poly SP Centrifugal, 14 HP Vanguard Gas Electric Start with Base and Flanges

Part Number	Accessories
116287-01	Optional Screw-in 220 Flange Adapter
116395-91	Base Rail Kit - 2" Poly Pump
116476-91	2" PSP Electric Front Mount Kit
116431-01	Optional Screw-in M300 Flange Adapter
116491-01A	3" Poly Pump Base Plate for Gas/10 HP Electric



IF YOU NEED A DE-ICING PUMP THAT'S PORTABLE, DURABLE, AND AFFORDABLE, OUR NEW LIGHTWEIGHT POLY-PUMP IS JUST WHAT YOU NEED.



PSP-3340



PSP-3240

In addition to being an excellent choice for most agriculture and industrial uses, John Blue Polypropylene Transfer Pumps are an excellent choice for transferring liquid de-icing product, to keep your surfaces free of ice and snow.

Specifically, our 3" PSP-3340 and 2" PSP-3240 pumps come fully-assembled from our factory, and are made entirely out of Polypropylene, FKM, Viton, and 316 Stainless Steel – they can handle even the harshest liquid de-icing products on the market! Dry salt products can cause concrete damage and leave behind a dusty, messy residue, but liquid salt products can give faster results, work in lower temperatures, and dry to a fine consistency that simply blows away (less mess!). John Blue Poly-Centrifugal pumps are the most dependable and affordable choice for your de-icing applications.

CAST-IRON CENTRIFUGAL PUMPS

NEXT GENERATION 2", 3", AND 4" SELF-PRIMING CENTRIFUGAL PUMPS

2-YEAR UNCONDITIONAL WARRANTY ON CAST-IRON TRANSFER PUMPS!*

All John Blue Centrifugal Pumps can run dry without damaging the seal. This, combined with a two-year factory-backed UNCONDITIONAL WARRANTY on cast-iron models, makes the John Blue Centrifugal Pumps second to no other pump manufacturer on the market today—all at an affordable price. Available with Gas, Electric, or Hydraulic Power Sources.

FEATURES:

- Patented Vac-U-Seal impeller design creates a vacuum between the impeller and mechanical seal. Lack of pressure on the seal face minimizes seal wear and results in a longer seal life.
- Double wet seal design provides for continuous lubrication of the seal faces. This wet seal design allows the pump to be run dry for extended periods with no damage to the mechanical seal faces.
- Closed impeller design minimizes thrust loading on the drive motor extending the life of the drive motor. Impeller wear increases performance, our pumps get better with use!

2-IN-1 INLET DESIGN ON SELF-PRIMING PUMPS:

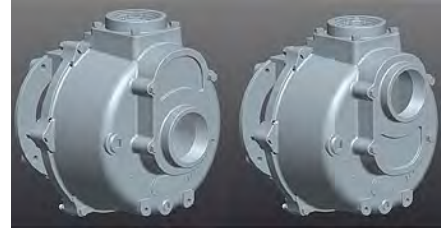

- Growers can select from 2 inlet locations on 1 Pump.
- The standard lower inlet with the backflow valve, yields maximum pump flow.
- The higher inlet allows the outlet lines to drain after shutoff while retaining self-priming capability on start-up.
- Patented

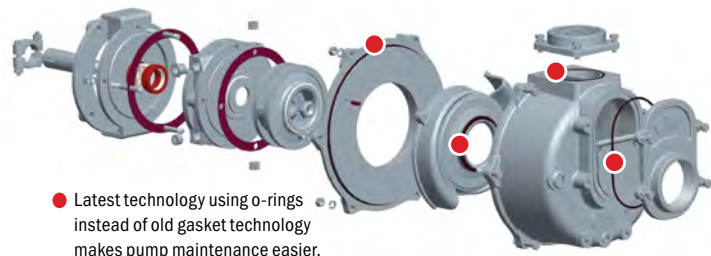

*2-year unconditional warranty is for cast-iron centrifugal transfer pumps only.



SP-3350-G14K
Kohler Engine (shown)
3" Self-Priming HF,
up to 400 GPM



SP-3240-G5H
2" NPT Self-Priming,
5 HP Honda, w/Base,
up to 200 GPM



SP-3350-G14VFLG
3" NPT Self-Priming,
14 HP Vanguard, Elec. Start,
w/Base, up to 400 GPM



SP-3350-G13HFLG
3" NPT Self-Priming,
13 HP Honda, Elec. Start,
w/Base, up to 400 GPM

Part Number	Pump Type*	Max Capacity GPM	Capacity @ 25 PSI	Max Pressure PSI	Max Speed RPM	Required HP	Inlet & Outlet FPT
Pumps For Gasoline Engines - Note: A Base Mounting for Engine Required							
S-3220	2" Straight, 3/4" Shaft	197	140	39	3600	5	2"
S-3320	3" Straight, 1 1/8" Shaft	365	310	60	3600	10	3"
SP-3240	2" Self-Priming, 3/4" Shaft	200	112	42	3600	5	2"
SP-3340	3" Self-Priming, 1 1/8" Shaft	340	265	64	3600	10	3"
SP-3350	3" Self-Priming, 1 1/8" Shaft	400	365	64	3600	13	3"
SP-3350-BS	3" Self-Priming, 1" Shaft	400	365	64	3600	13	3"
SP-3450-BS	2nd Gen HF 4"x3" SP Cent-Gas	560	470	64	3600	20	4" x 3"

- Keyed shaft clamp standard on 3" -BS gasoline engine pumps.

Pumps Coupled To Gasoline Engines							
S-3220-G5H	2" Straight, 5 HP Honda Engine with Base	197	140	39	3600	5	2"
SP-3240-G5H	2" Self-Priming, 5 HP Honda Engine With Base	200	112	42	3600	5	2"
SP-3240-G6B	2" Self-Priming, 6 HP Briggs & Statton Pro Engine	200	112	42	3600	5	2"
NEW! SP-3240-G6HE	2" Self-Priming Cast-Iron Centrifugal, 6 HP Honda GX200 Engine with Electric Start and Base	200	112	42	3600	6	2"
SP-3350-G13H	3" Self-Priming, 13 HP Honda, Electric Start, Engine with Base	400	365	64	3600	13	3"
SP-3350-G14K	3" Self-Priming, 14 HP Kohler, Electric Start, Engine with Base	400	365	64	3600	14	3"
SP-3350-G14V	3" Self-Priming Cast-Iron Centrifugal, 14 HP Vanguard	400	365	64	3600	14	3"

* Pump size given in inches refers to inlet and outlet sizes.

- Silicon-Carbide seals available on 2" and 3" pumps, add -C after part number.

- Flange option available on 2" and 3" pumps, add -FLG after part number.



S-3220-E
2" Straight,
up to 197 GPM



SP-3240-E
2" Self-Priming,
up to 200 GPM



SP-3350-E
3" Self-Priming,
up to 400 GPM



SP-3350-E15TB:
3" NPT Self-Priming,
15 HP, 3 Phase, TEFC,
with Base, up to 400 GPM



SP-3450-E20TB:
4"x3" NPT Self-Priming
20 HP, 3 Phase,
TEFC w/Base,
up to 560 GPM

Part Number	Pump Type*	Max Capacity GPM	Capacity @ 25 PSI	Max Pressure PSI	Max Speed RPM	Required HP	Inlet & Outlet FPT
Pumps for Electric Motors							
S-3220-E	2" Straight, 3/4" Shaft	197	140	39	3600	5	2"
S-3320-E	3" Straight, 1 1/8" Shaft	365	310	60	3600	10	3"
SP-3240-E	2" Self-Priming, 3/4" Shaft	200	112	42	3600	5	2"
SP-3340-E	3" Self-Priming, 1 1/8" Shaft	340	265	64	3600	10	3"
SP-3350-E	3" Self-Priming HF, 1 1/8" Shaft	400	365	64	3600	15	3"
SP-3450-E	2nd Gen HF 4"x3" SP Cent Elect	560	470	64	3600	19	4"x3"
Pumps Coupled to Electric Motors							
S-3220-E5D3	2" Straight, 5 HP 3 Phase	197	140	39	3600	5	2"
S-3320-E10T	3" Straight, 10 HP Electric TEFC, 3 Phase	365	310	60	3600	10	3"
S-3320-E15T	3" Straight, 15 HP Electric TEFC, 3 Phase	365	310	60	3600	15	3"
SP-3240-E5D1B	2" self-priming drip proof, single phase with base	200	112	42	3600	5	2"
SP-3240-E5D3B	2" Self-Priming 5 HP Electric Drip Proof, 3 Phase with Base	200	112	42	3600	5	2"
SP-3240-E5T3B	2" Self-Priming 5 HP Electric TEFC, 3 Phase with Base	200	112	42	3600	5	2"
SP-3340-E10TB	3" Self-Priming, 10 HP Electric TEFC, 3 Phase	340	265	64	3600	10	3"
SP-3340-E10TB-1	3" Self-Priming, 10 HP Electric TEFC, 1 Phase	340	265	64	3600	10	3"
SP-3350-E15TB	3" Self-Priming HF, 15 HP Electric TEFC, 3 Phase with Base	400	365	64	3600	15	3"
SP-3450-E20TB	2nd Gen HF 4"x3" SP Cent with 20 HP Electric Motor w/ Base	560	470	64	3600	20	4"x3"

*Pump size given in inches refers to inlet and outlet sizes.

**Power based on electric motor with full voltage and pumping water..



SP-3240-PH2
2" Self-priming Hydraulic Drive, up to 200 GPM

S-3325-PH
3" Straight Truck Pump Hydraulic Drive, up to 365 GPM



Part Number	Pump Type*	Max Capacity GPM	Capacity @ 25 PSI	Max Pressure PSI	Max Speed RPM	Required HP	Inlet & Outlet FPT
Pumps With Pedestal Mount							
S-3220-P	2" Straight, 3/4" Shaft	197	140	39	3600	5	2"
S-3320-P	3" Straight, 1 1/8" Shaft	365	310	60	3600	10	3"
S-3325-P	3" Straight Truck Pump, 1 1/8" Shaft	463	430	99	4500	16.5	3"
SP-3240-P	2" Self-Priming, 3/4" Shaft	200	112	42	3600	5	2"
SP-3340-P	3" Self-Priming, 1 1/8" Shaft	340	265	64	3600	10	3"
SP-3350-P	3" Self-Priming, 1 1/8" Shaft	400	365	64	3600	15	3"
SP-3345-P	3" Self-Priming Truck Pump 1 1/8"	340	265	64	3600	10	3"
Pumps Coupled To Hydraulic Motors (includes hydraulic motor)							
NEW! S-3220-PH2	2" Straight Hydraulic Drive	197	140	39	3600	10	2"
S-3325-PH	3" Straight Truck Pump Hydraulic Drive	365	310	60	3600	10	3"
NEW! SP-3240-PH2	2" Self-Priming Hydraulic Drive	200	112	42	3600	5	2"
SP-3345-PH	3" Self-Priming Truck Pump Hydraulic Drive	340	265	64	3600	10	3"

*Pump size given in inches refers to inlet and outlet sizes.

- Low-flow hydraulic motors are available on Hydraulic Truck Pumps Straight 3" (S-3325-PHL) and Self-priming 3" Hydraulic Truck Pump (SP-3345-PHL).

- Standard motors require 25 GPM for full pump flow and low-flow motors require 14 GPM.

Miscellaneous Centrifugal Components and Kits	
-FLG	Flanges available on all centrifugal pumps; Add -FLG after part number.
116001-01	Flange Adapters Ductile Iron, 2" NPT to 220 Series
116002-01	Flange Adapters Ductile Iron, 3" NPT to 300 Series
116228-01	Bulk quantity baseplates (20 Min. Qty.) for customer supplied SP-3320-BS and SP-3350-BS w/13 HP Honda, hardware not included.
116230-91	Baseplate Kits for customer supplied SP-3320-BS and SP-3350-BS with 13 HP Honda Engine, includes baseplate and hardware.
116251-01	Bulk quantity baseplates (20 Min. Qty.) for 2" Straight and Self-Priming Pumps, hardware not included
116252-91	Baseplate Kits for 2" Straight and Self-Priming Pumps, includes baseplate and hardware.
116843-91	2" Pedestal Assembly with Hydraulic Motor, SAE A-A Flange



CENTRIFUGAL SPRAY PUMPS



EFFICIENT AND VERSATILE CENTRIFUGAL SPRAY PUMPS FOR HYDRAULIC, GAS ENGINE AND SHAFT DRIVES

John Blue Company offers a wide range of centrifugal spray pumps designed for different drives, including hydraulic, shaft, and engine drives. New to the lineup this year are the Centrifugal Spray Pumps with 12 GPM Hydraulic Motor and 6HP Honda Engine with Electric Start! All of our Centrifugal Spray Pumps move your hard-to-handle products quickly and efficiently. Our chemical-resistant cast iron pumps are designed for agricultural and industrial spraying and are used for various applications.



1-YEAR WARRANTY

John Blue CS Series Pumps hold a 1-Year Warranty from the date of sale. Tried and true, depend on Blue.

CENTRIFUGAL SPRAY PUMPS WITH 6HP HONDA ENGINE AND ELECTRIC START

The 6HP Honda Engine with Electric Start is now available for specific John Blue Cast-Iron, Poly, and Centrifugal Spray Pumps.

ELECTRIC START ENGINE

- Easy Starting
- Exceptionally Quiet
- Smooth Performance
- Proven Reliability

JOHN BLUE CENTRIFUGAL PUMPS

- Double Wet Seal Technology
- Fully Assembled from Factory
- Durable Construction
- Vac-U-Seal Impeller



AVAILABLE FOR CAST-IRON, POLY, AND SPRAY PUMPS!



NEW HA12 HYDRAULIC MOTOR BENEFITS

► Increased pump performance due to higher speed and power

The new larger displacement and higher speed hydraulic motor allows the pumps to provide maximum performance.

► Regulates hydraulic flow for protection of motor components

The factory installed orifice allows a maximum of 12 GPM of hydraulic flow to enter the hydraulic motor preventing premature wear and damage.

► Anti-cavitation protection

The hydraulic motor utilizes an anti-cavitation valve that prevents damage from cavitation when the inlet pressure decreases as the pump is stopped.

► High pressure motor shaft seal

Includes a factory installed high pressure shaft seal to extend its life.

► Prevents plumbing confusion

No additional check valves are required. Check valve is factory installed in the outlet of the motor to prevent unintended reverse hydraulic connection.



CENTRIFUGAL SPRAY PUMPS WITH DOUBLE WET SEAL FOR HYDRAULIC DRIVES

The Centrifugal Spray Pump hydraulic motor has been totally reimagined – increased pump output performance, service life, and motor protection.

CS-150-HY/CS-150-HYR

150 GPM Max Flow
80 PSI Max Pressure
145 GPM @ 25 PSI
1½" FPT and 220 Flanged Inlet
1¼" FPT and 200 Flanged Outlet
4 GPM Max Hydraulic Flow Required
3000 PSI Max Hydraulic Pressure Required

*CS-150-HYR, CS-150-HA12, and CS-200-HA12 Equipped with Factory Installed Motor Protection



CS-150-HY

CS-150-HA12

158 GPM Max Flow
115 PSI Max Pressure
158 GPM @ 55 PSI
1-1/2" FPT & 220 Flanged Inlet
1-1/4" FPT & 200 Flanged Outlet
12 GPM Max Hydraulic Flow Required
3000 PSI Max Hydraulic Pressure Required



CS-150-HA12

CS-200-HA12

173 GPM Max Flow
105 PSI Max Pressure
171 GPM @ 55 PSI
2" FPT Inlet
1-1/2" FPT Outlet
12 GPM Max Hydraulic Flow Required
3000 PSI Max Hydraulic Pressure Required



CS-200-HA12

CENTRIFUGAL SPRAY PUMPS FOR GAS ENGINES

142 GPM Max Flow @ 3600 RPM
105 PSI Max Pressure @ 3600 RPM
135 GPM @ 25 PSI
Max Speed 3600
1½" FPT and 220 Flanged Inlet
1¼" FPT and 200 Flanged Outlet
Required Horsepower: 5HP
5/8" and 3/4" Shafts Available on Gas Engine Models



CS-155RG-5H



CS-150

CS-150 SHAFT ONLY CENTRIFUGAL SPRAY PUMPS

- 151 GPM Max Flow @ 3750 RPM
- 80 PSI Max Pressure @ 3750 RPM
- Shaft Size: 5/8" Outer Diameter
- 1 1/2" FPT and 220 Flanged Inlet
- 1 1/4" FPT and 200 Flanged Outlet
- Vac-U-Seal Impeller
- Double Wet Seal Assembly
- Chemical Resistant Materials
- Fully Assembled From the Factory

Centrifugal Spray Pump with Double Wet Seal for Hydraulic Drive



Part Number	Pump Type
CS-150-H	1-1/2" x 1-1/4" (220 and 200 Flange) Spray Centrifugal, with Hydraulic Adapter
CS-150-HY	1-1/2" x 1-1/4" (220 and 200 Flange) Spray Centrifugal, with 4 GPM Hydraulic Motor
CS-150-HYR	1-1/2" x 1-1/4" (220 and 200 Flange) Spray Centrifugal, with 4 GPM Hydraulic Motor, Factory Installed Motor Protection
NEW! CS-150-HA12	1-1/2" x 1-1/4" Spray Centrifugal, with 12 GPM Hydraulic Motor. Factory Installed Motor Protection
NEW! CS-200-HA12	2" x 1-1/2" Spray Centrifugal, with 12 GPM Hydraulic Motor, Factory Installed Motor Protection

Centrifugal Spray Pump for Shaft & Engine Drives



Part Number	Pump Type
CS-150	1-1/2" x 1-1/4" Spray Centrifugal, Shaft only
CS-155RG	1-1/2" x 1-1/4" Spray Centrifugal, Reverse Rotation, for Gas Engine, 3/4" Engine Shaft
CS-155RG-5/8	1-1/2" x 1-1/4" Spray Centrifugal, Reverse Rotation, for Gas Engine, 5/8" Engine Shaft
CS-155RG-5H	1-1/2" x 1-1/4" Spray Centrifugal, with GX 160 Honda Engine, 5 HP
NEW! CS-155RG-6HE	1-1/2" x 1-1/4" Spray Centrifugal, 6HP Honda GX200 Engine with Electric Start
CS-155RG-6B	1-1/2" x 1-1/4" Spray Centrifugal, with Briggs Pro Engine, 6 HP

CS-150-HY & HYR PUMP PERFORMANCE DATA AT VARIOUS PUMP SHAFT SPEEDS

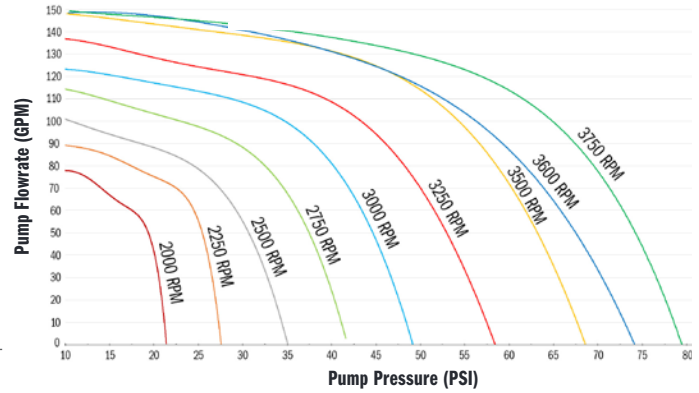

CS-150-HA12 PUMP PERFORMANCE DATA AT VARIOUS PUMP SHAFT SPEEDS

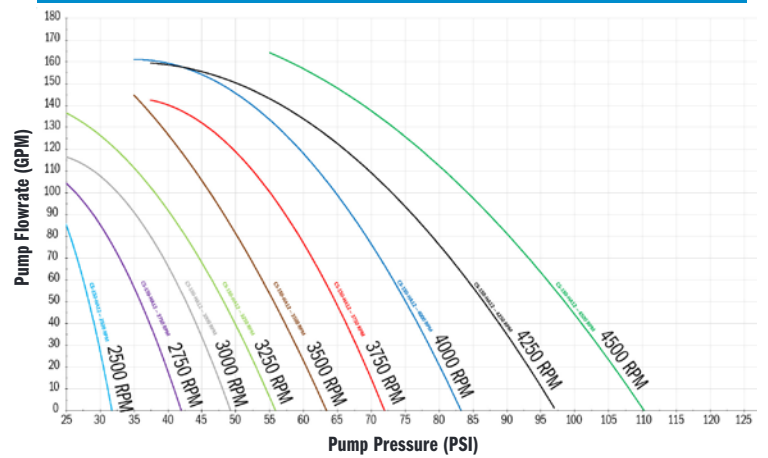

CS-200-HA12 PUMP PERFORMANCE DATA AT VARIOUS PUMP SHAFT SPEEDS

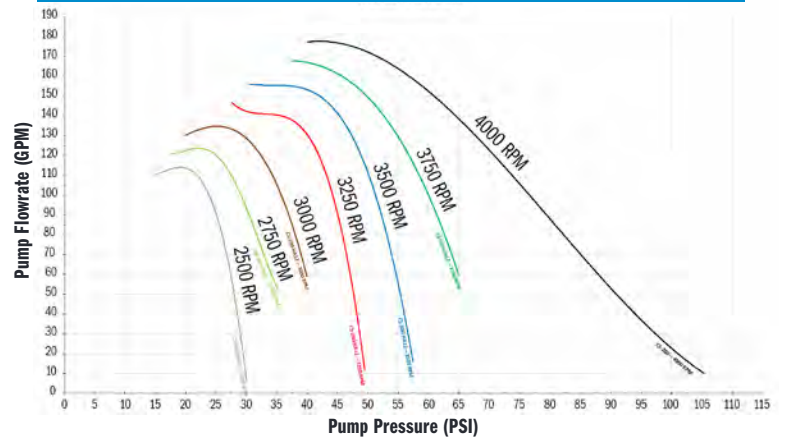

CS-155RG PUMP PERFORMANCE DATA AT VARIOUS PUMP SHAFT SPEEDS

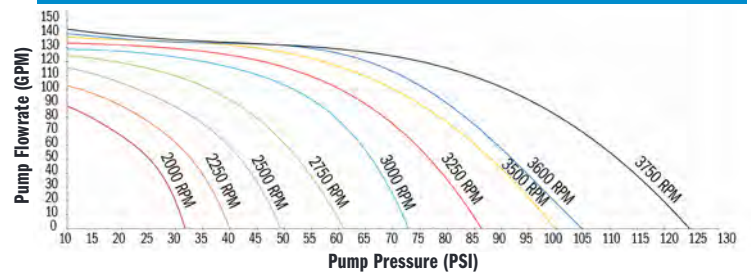



INJECTION
PUMPS

3
IRRIGATION
INJECTION PUMPS

IRRIGATION INJECTION PUMPS AND CHECK VALVES

John Blue irrigation injection pumps are a staple in the chemigation and fertigation industry. Choose between our robust Large-Range units and the proven E-Z Meter Injection Series, both designed with the end-user in mind. The Large-Range models utilize proven piston pump technology, renowned for their robustness, durability, and reliability. The E-Z Meter Series is lightweight and dependable, featuring an easy-to-read setting system that makes it ideal for moving between pivots.

IRRIGATION INJECTION PUMPS AND CHECK VALVES

Piston Metering Injection Pumps 49
E-Z Meter Pumps 50-51
Injection Check Valves 52



FULL RANGE INJECTION PUMPS

Pump models have a range of application from 1.6 to 114 GPH or all the way up to 6 to 470 GPH.

All internal wetted parts are constructed with corrosion resistant stainless steel to ensure optimum performance over many years of service.

All working parts are totally enclosed for maintenance free service.

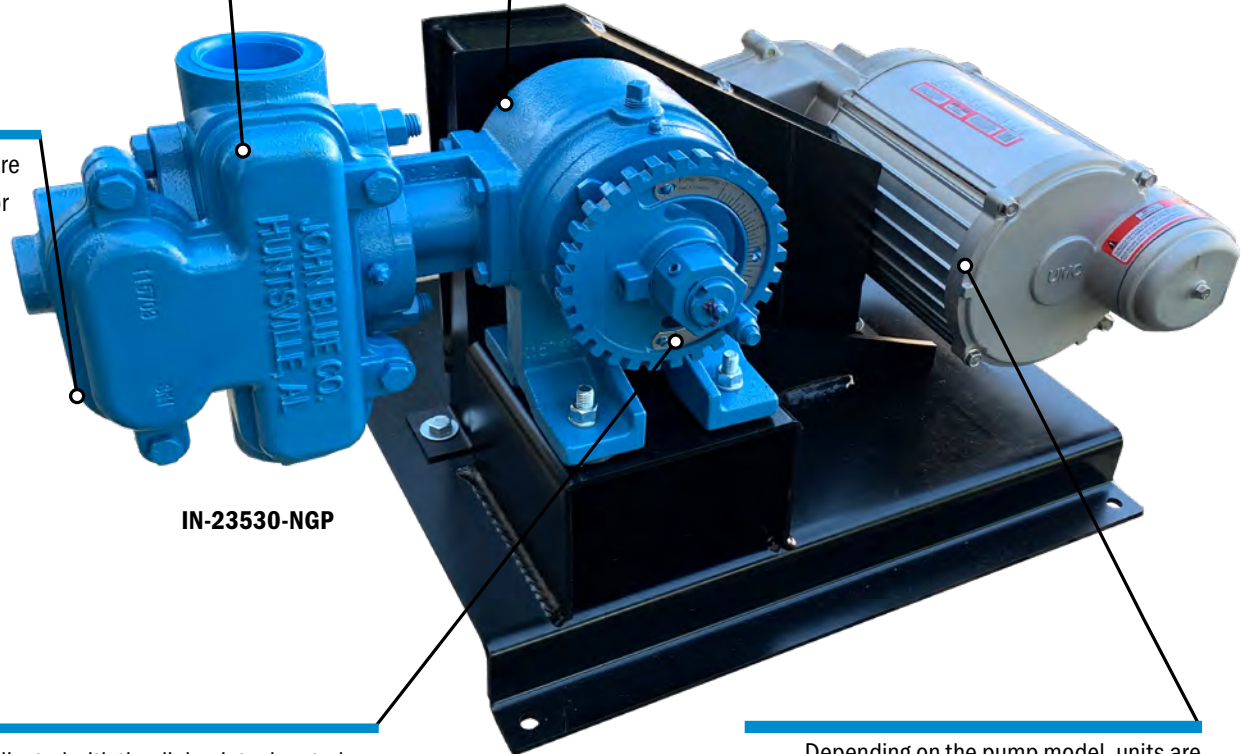

IN-23530-NGP

Rates are easily adjusted with the dial pointer located on the side of the pump, which changes the length of the stroke.

Depending on the pump model, units are available with $\frac{3}{4}$ or $1 \frac{1}{2}$ HP motor and gearbox.

Piston Pump Injection Pumps

Model Number	Phase	Model Type	Low Range GPH	High Range GPH	Max PSI	Motor Size	GPH Range
IN-11610-NGP	Single	Simplex	2.6-26.2	5.9-59	120	1 ½	2.6-117
		Duplex	5.2-52.4	11.7-117.4	120	1 ½	
IN-11630-NGP	Three	Simplex	1.6-15.5	5.7-57	120	$\frac{3}{4}$	1.6-114
		Duplex	3.1-31	11.4-114	120	$\frac{3}{4}$	
IN-23510-NGP	Single	Simplex	5.5-55	12-122	120	1 ½	5.5-242
		Duplex	11-108	24-242	120	1 ½	
IN-23530-NGP	Three	Simplex	3-32	12-119	120	$\frac{3}{4}$	3-235
		Duplex	6-64	24-235	120	$\frac{3}{4}$	
IN-47010-NGP	Single	Simplex	8.2-81.9	18.4-183.8	120	1 ½	8.2-363
		Duplex	16.2-162	36.3-363	120	1 ½	
IN-47030-NGP	Three	Simplex	6-64.8	24-238	120	1 ½	6-470
		Duplex	12-128	48-470.2	120	1 ½	

*316 stainless steel available on any IN-235 or IN-470 models. Add -S after the part number.



E-Z METER INJECTION PUMPS

E-Z METER INJECTION PUMP FEATURES:

- Available in simplex and duplex models with numerous power sources.
- All parts exposed to agricultural products are made from 316 stainless steel, chemical resistant polypropylene and the highest quality seals available today.
- Accurate injection rates, maximum dependability and long-term reliability.

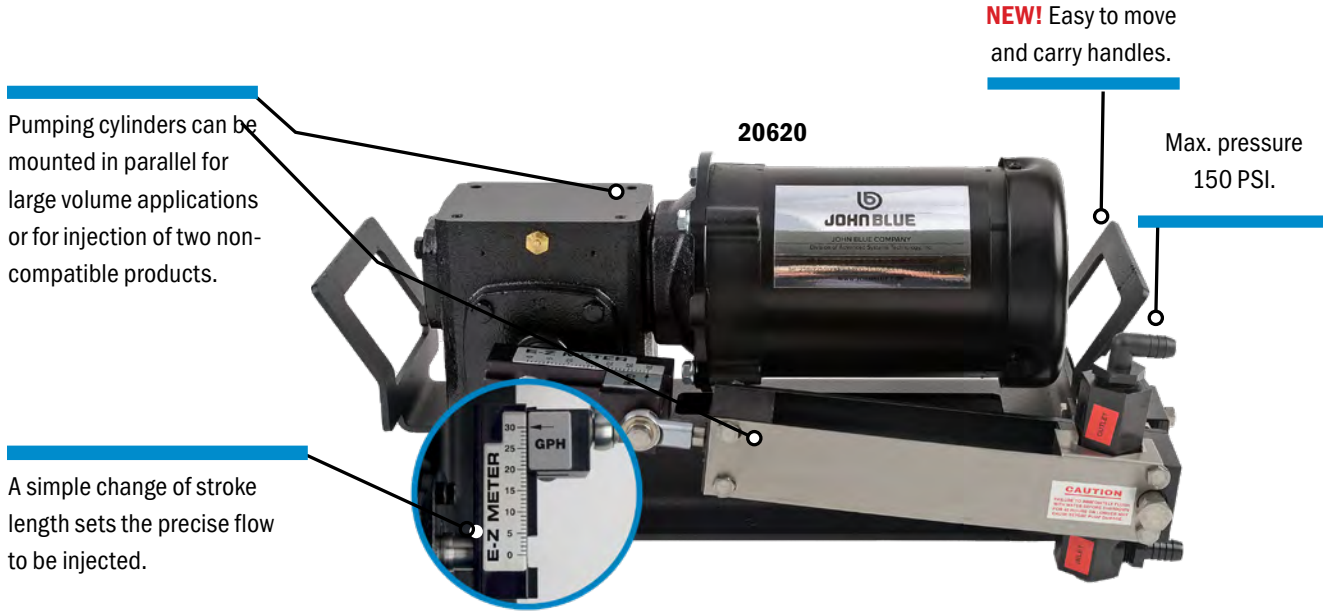

**LOW
MAINTENANCE**

**NO
CALIBRATION
TEST**

**AFFORDABLE
PRICE**

VFD Now Available!

Contact us for more info



The upgraded seals are more forgiving when the pump is run dry between supply tank refills. The John Blue piston cup shape provides a positive seal without the need for future adjustments. Piston cups can be changed in the field with standard tools.



E-Z METER INJECTION PUMPS*

Maximum Pressure 150 PSI

316 Stainless Steel Cylinder Models

E-Z Meter Injection Pumps					
Power Source	5-30 GPH	10-100 GPH	5-30 5-30 GPH	5-30 10-100 GPH	10-100 10-100 GPH
110-220 1ph	10620	11630	10622	10623	10633
220-440 3ph	20620	21630	20622	20623	20633
Belt Drive	01620	01630	01622	01623	01633
Honda Engine	02620	02630	02622	02623	02633
12V DC Motors	30620	30630	30622	30623	30633

*-1 after the part number indicates pumps with Teflon™ cylinders, ideal for acid applications. For stainless steel check valves contact the factory.

E-Z Meter Field Conversion Parts and Options	
Model Number	Description
50520	Duplex Field Conversion 5-30 GPH E-Z Meter Pump
50530	Duplex Field Conversion 10-100 GPH E-Z Meter Pump
115026-HS	¼" FNPT inlet x ¼" MNPT outlet (with tube) 316 SS Backflow Check Valve for Irrigation Line
115030	¼" MNPT inlet x ¼" FNPT outlet Backflow Check Valve for Irrigation Line
CV-1310	¼" FNPT inlet x ½" MNPT outlet (with tube) Poly Check Valve for Irrigation Line
CV-1310-BL	¼" FNPT inlet x ½" MNPT outlet (with tube) Poly Check Valve for Irrigation Line with PVC bleeder valve.

*Pumps produced prior to 2005 can only be duplexed if originally supplied with a dual output shaft gearbox used on 10-100 units, gasoline or belt drive pumps.

E-Z Meter Power Sources: 5-30, 10-100 and 10-200 GPH Pumps

115/208-230V SINGLE PHASE, 60 HZ.

½ HP, 1725 RPM, 115/208-220V, FLA 8.8/4.4, 56C Frame, HZ 60 single phase, SFA 9.4/4.7, service factor, 1.15 ball bearings. (50 HZ motors available upon request).

208-230/440V THREE PHASE, 60 HZ.

½ HP, 1725 RPM, 208-230/440V, FLA is 2.1-2.0/1.0, 56C Frame, HZ 60, three phase, SFA 2.5-2.4/1.2, service factor, 1.25 ball bearings. (50 HZ motors available upon request).

HONDA GASOLINE ENGINE DRIVEN (GED)

4 cycle, 7.2 CID with 4 HP at 3600 RPM, fuel capacity .66 US gallons.

12 VOLT

½ HP, 1800 full load RPM, 12 Volts DC F.L. AMPS 40, 24 Volts DC 20 F.L. AMPS, Class F insulation, linear speed/torque, NEMA 56C frame, ball bearings. Manufacturer reserves the right to make changes to specifications.



E-Z Meter Pumps with the double ball, built-in check valves provide better performance by virtually eliminating air locking. Available in 316 stainless steel or Teflon™ cylinders.



CV-1310-BL



115026-HS



CV-1310

INJECTION CHECK VALVE FEATURES

200 GPH maximum capacity continuous flow (duplex pump - 2 strokes per revolution)

100 GPH maximum capacity (simplex - 1 stroke per revolution)

More uniform distribution of products

Prevents backflow, siphoning and bleed through of product

Easy to install and maintain

All Viton® seals

316 stainless steel spring, ball and injection tube

10 PSI spring

- ◀ Bodies available in either polypropylene (CV-1310) or 316 stainless steel (115026-HS)
- ◀ CV-1310-BL - Polypropylene check valve with PVC bleeder valve





DIAPHRAGM
PUMPS

4
DIAPHRAGM
PUMPS

DIAPHRAGM PUMPS AND ACCESSORIES

John Blue Diaphragm Pumps are the industry leader for all your chemical spraying needs. Whether you need a pump for turf, lawns, trees, orchards, large acreage, or starter fertilizer applications, John Blue has the right diaphragm pump for you. Our unique poly pump line handles low pH chemicals and other corrosive items. Our medium pressure pumps are ideal for pest control and lawn spraying, while our high pressure, high volume pumps excel in cleaning and sanitizing poultry houses. John Blue Diaphragm Pumps will meet and exceed your expectations.

DIAPHRAGM PUMPS AND ACCESSORIES

Low Pressure Poly Pumps 53-59
Medium Pressure Pumps..... 60-62
High Pressure Pumps..... 63-65
Spray Control Units and Spray Guns..... 66-69
Diaphragm Pumps Miscellaneous Kits 70-71
Diaphragm Pumps In-Use 72



LOW-PRESSURE POLY DIAPHRAGM PUMPS

LOW PRESSURE POLY DIAPHRAGM PUMP FEATURES:

- All fluid end components are polypropylene and 316 stainless steel, offering amazing reliability and service for even the most aggressive chemicals including acid and highly corrosive products.
- John Blue self-lubricating cast iron piston sleeves provide a unique “oil-thrust-pad” design.
- Bronze connecting rods and diaphragms constructed from resistant elastomers provide economical and trouble free service.
- The heads are designed with a new patented technology that includes an aluminum die-cast core inside a polypropylene structure offering superior strength.
- Pre-deformed diaphragms in a specially formulated chemical resistant material, 316 stainless steel washer and diaphragm bolt offer strength and resistance to chemical attack.
- Pre-deformed diaphragm allows for reduced deflection and longer life.
- Two, three, four, five and six piston semi-hydraulic Diaphragm Pumps assure a smooth and quiet operation even with high volume flow.
- Reduced piston stroke decreases diaphragm deflection providing long life operation.
- Other benefits of Poly Pumps include low maintenance costs and interchangeability of heads, diaphragms and associated components across most of the Poly Pump line.
- Convenient visual oil-level indicator.
- Pumps can be run dry.
- Individual suction and pressure manifolds for smoother flow through the pump.



LOW-PRESSURE POLY DIAPHRAGM PUMPS

EXCLUSIVE, PATENTED TECHNOLOGY:

- Pumps come standard with internal pressure dampener.
 - Standard, interchangeable parts for reduced inventory and best service.
 - Full range: 2,3,4,5,6 diaphragms available.
1. The heads are designed with a patented technology that includes an aluminum die-cast core inside a polypropylene structure offering superior strength.
 2. Washers and diaphragm bolts in 316 stainless steel, an exclusive feature.
 3. Die cast crankcase incorporating a new cooling system.
 4. New chemically resistant diaphragm material pre-deformed to reduce the amount of deflection, increasing diaphragm life. The diaphragm material is compatible with most of the corrosive chemicals on the market today.
 5. A short crankshaft stroke means the longest life possible.
 6. New connecting rods in special bronze alloy offer economical and trouble free service.
 7. 316 stainless steel and polypropylene inlet and outlet check valves.

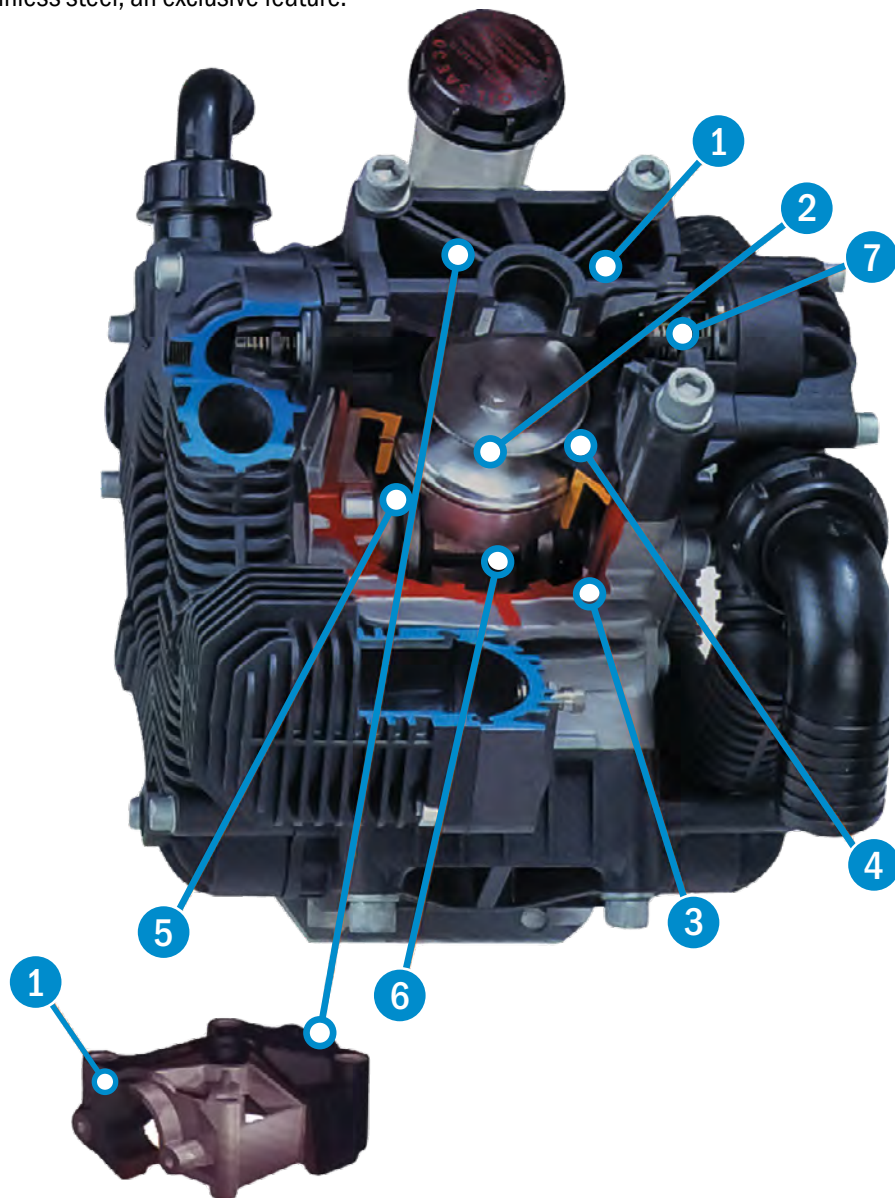

ADVANTAGES OF LOW PRESSURE POLY DIAPHRAGM PUMPS

- » Low Pressure Diaphragm Pumps operate to 4.3 GPM with pressure ratings to 290 PSI
- » Cast iron piston sleeves for longer wear
- » Convenient visual oil-level indicator
- » Stainless steel check valve design ensures perfect sealing performance due to its unique spherical shaped poppet and conical seat
- » Three bearings on the crankshaft
- » Pumps can be run dry

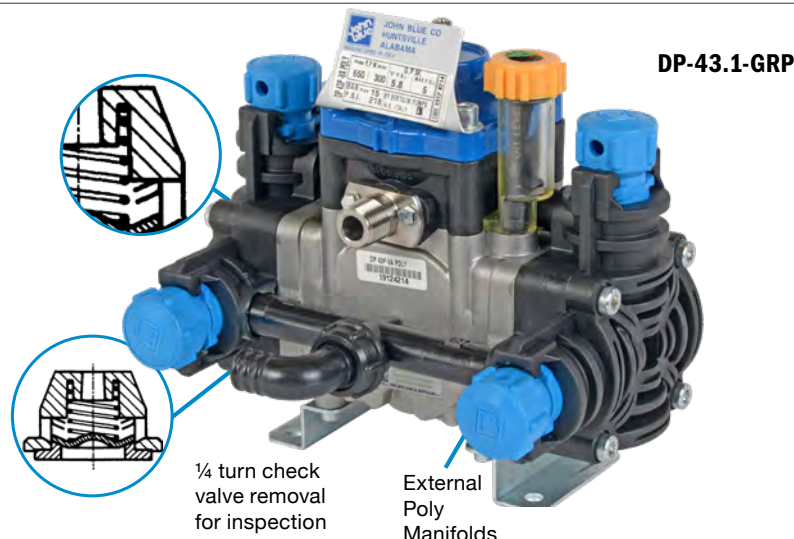

DP-43-FP

Maximum Flow: 4.3 GPM @ 550 RPM and 290 PSI
 Maximum Pressure: 290 PSI
 Maximum Speed: 650 RPM
 Maximum Power: 1.0 HP @ 550 RPM and 290 PSI
 Weight: 13 lbs
 Diaphragms: 2
 Suction Hose Diameter: 3/4" Hose
 Discharge Hose Diameter: 1/2" NPT
 Max Temperature: 140°F
 Lubricating Oil Type: 30 SAE
 Can be PTO, gasoline engine or electric motor driven

Recommended Accessories:

- Pressure Regulator: SC-1066-2.
- Gearbox for 3.5 and 5 HP engines: DP-321009.
- Pump equipped with crankshaft flange, must order shaft separately: DP-318793 (3/4") solid shaft or DP-318590 (1") solid shaft.

Optional Accessories:

DP-310088 Female 1 3/8" shaft kit
DP-310049 Male 1 3/8" shaft kit
DP-31874897 Hydraulic adaptor kit SAE "B"

DP-43 Performance - RPM								
Pressure	500		550		600		650	
	GPM	HP	GPM	HP	GPM	HP	GPM	HP
29	4.38	.09	4.8	0.10	5.28	1.1	5.73	0.13
145	4.0	.48	4.38	0.52	4.78	0.57	5.1	0.60
218	3.96	.71	4.3	0.78	4.73	0.85	5.07	0.90
290	3.93	.94	4.3	1.0	4.7	1.13	5.0	1.2



Optional Models:

DP- 43.1-GRIP

DP-43.1-GRIP2.2

DP-43-P

DP-43.1-GRP

All Available in Poly

Poly Pump includes gearbox for 3.5 and 5 HP engines and regulator with (2) outlets and shut-off valve.

Poly Pump includes gearbox for 2.2 HP Honda engine with and regulator with (2) outlets and shut-off valve.

Mini Poly Pump - total chemical resistance to harsh chemicals and fertilizers. Has 3/4" solid shaft.

Mini Poly Pump includes gearbox for 3.5 and 5 HP engines, does not include a regulator. Poly Pump guarantees total chemical resistance to harsh chemicals and fertilizers.

Mini Poly Pumps have total chemical resistance to harsh chemicals and fertilizers.

DP-70-FP



DP-70-FP

Maximum Flow: 6.0 GPM @ 550 RPM and 290 PSI
 Maximum Pressure: 290 PSI
 Maximum Speed: 650 RPM
 Maximum Power: 1.4 HP @ 550 RPM and 290 PSI
 Weight: 13 lbs
 Diaphragms: 2
 Suction Hose Diameter: 1" hose
 Discharge Hose Diameter: 3/4" npt
 Max Temperature: 140° F
 Lubricating Oil Type: 30 SAE
 Can be PTO, gasoline engine or electric motor driven

Recommended Accessories:

- Pressure Regulator: SC-1132-2.
- Gearbox for 5 HP engines: DP-321009.
- DP-318793 (3/4") or DP-318590 (1") solid shaft.

Optional Accessories:

- DP-318343** Female 1 3/8" shaft kit
- DP-310049** Male 1 3/8" shaft kit
- DP-31874897** Hydraulic adaptor kit SAE "B"
- DP-94994297** Repair Kit
- DP-94994497** Valve Kit



SC-1132-2

DP-70.1-GRP



Optional Models:

- DP- 70.1-GRIP** **All Available in Poly**
Poly Pump includes gearbox for 3.5 and 5 HP engines and regulator with (2) outlets and shut-off valve.
- DP-70-P** Total chemical resistance to harsh chemicals and fertilizers. Has 3/4" solid shaft.
- DP-70.1-GRP** Poly Pump includes gearbox for 3.5 and 5 HP engines, does not include a regulator.

DP-70-P Performance - RPM

Pressure	500		550		600		650	
	GPM	HP	GPM	HP	GPM	HP	GPM	HP
29	6.3	0.1	6.9	0.2	7.6	0.2	8.2	0.2
145	5.9	0.7	6.5	0.7	7.1	0.8	7.7	0.9
218	5.7	1.0	6.3	1.1	6.8	1.2	7.4	1.2
290	5.5	1.2	6.0	1.4	6.6	1.5	7.1	1.6



DP-193-PP

Maximum Flow: 19.8 GPM	Weight: 25 lbs.
Maximum Pressure: 218 PSI	Suction Hose Diameter: 1 1/2" Hose
Maximum Speed: 550 RPM	Discharge Hose Diameter: 1" NPT
Maximum Power: 2.8 HP	Max Temperature: 140°F
Diaphragms: 3	Lubricating Oil Type: 30 SAE
Negative Pressure - Max: 4.9 ft., Intermittent: 9.8 ft.	Drive Shaft: 1" diameter (one side only)

- Optional Models:** **All Available in Poly**
- DP-193-GRP** Includes gearbox for 3.5 & 5 HP engines
 - DP-193-GRIP** Includes gearbox for 3.5 & 5 HP engines and SC-2420-3 regulator

Recommended Accessories:

- Control Units: SC-2420-3, SC-2660-3
- Gearbox for 5 HP gasoline engine with 3/4" shaft: DP-321003
- Hydraulic Adapter (SAE "B") : DP-31874997
- Hydraulic Adapter (SAE "A") : DP-31922897

DP-193-PP Performance - RPM								
Pressure	400		450		500		550	
	GPM	HP	GPM	HP	GPM	HP	GPM	HP
29	14.4	0.3	16.2	0.3	18.0	0.4	19.8	0.4
73	14.2	2.7	16.0	0.8	17.8	0.9	19.6	1.0
145	13.8	1.4	15.6	1.5	17.3	1.7	19.0	1.9
218	13.5	2.0	15.1	2.3	16.8	2.5	18.5	2.8



DP-282.1-P

Maximum Flow: 28.2 GPM	Weight: 42 lbs.
Maximum Pressure: 218 PSI	Suction Hose Diameter: 1 1/2" Hose
Maximum Speed: 550 RPM	Discharge Hose Diameter: 1" NPT
Maximum Power: 4.1 HP	Max Temperature: 140°F
Diaphragms: 3	Lubricating Oil Type: 30 SAE
Negative Pressure - Max: 4.9 ft., Intermittent: 9.8 ft.	Through input shaft: 1" diameter one end, 1 3/8" 6-spline opposite end

DP-282-P Performance - RPM								
Pressure	400		450		500		550	
	GPM	HP	GPM	HP	GPM	HP	GPM	HP
29	20.6	0.4	23.1	0.5	25.7	0.5	28.3	0.6
73	20.4	1.0	22.9	1.1	25.5	1.3	28.0	1.4
145	20.2	2.0	22.5	2.3	25.2	2.5	27.7	2.8
218	20.0	3.0	15.1	3.3	25.0	3.7	27.5	4.1

Made with the **NEW DURAMAX DIAPHRAGM**—mechanical elasticity with controlled deformation! DuraMax diaphragms have been conceived as “pre-deformed” and provide longer life and more performance with any kind of chemical used. The plastic polymer provides great strength and long-lasting reliability over time. The diaphragm washer is made of stainless steel to prevent abnormal deformation of the diaphragm and guides it along the piston stroke. The piston crown has a friction-proof form to eliminate wear caused by rubbing.

- Recommended Accessories:**
- Control Units: SC-2420-3, SC-2660-3
 - Gearbox for 5 HP gasoline engine with 3/4" shaft: DP-321003 must use DP-31155907 spacer and (4) bolts DP-86357500.
 - Hydraulic Adapter (SAE "B"): DP-31874997 must use (1) DP-31155907 spacer and (4) bolts DP-86357500.



DP-332-P

Maximum Flow: 33.3 GPM	Suction Hose Diameter: 1 1/2" Hose
Maximum Pressure: 218 PSI	Discharge Hose Diameter: 1" NPT
Maximum Speed: 550 RPM	Max Temperature: 140°F
Maximum Power: 4.8 HP	Lubricating Oil Type: 30 SAE
Weight: 42 lbs.	Through input shaft: 1" diameter one end,
Diaphragms: 3	1 3/8" 6-spline opposite end
Negative Pressure - Max: 4.9 ft.	
Intermittent: 9.8 ft.	

Recommended Accessories:

- Control Units: SC-2420-3, SC-2660-3
- Gearbox for 5 HP gasoline engine with 3/4" shaft: DP-321003 and requires the DP-31155907 spacer and (4) DP-86357500 bolts.
- Hydraulic Adapter (SAE "B"): DP-31874997 must use (1) DP-31155907 spacer and (4) bolts DP-86357500.

DP-332-P Performance - RPM								
Pressure	400		450		500		550	
	GPM	HP	GPM	HP	GPM	HP	GPM	HP
29	24.2	0.5	27.2	0.5	30.3	0.6	33.3	0.7
73	24.0	1.2	27.0	1.3	30.0	1.5	33.0	1.6
145	23.8	2.4	26.8	2.7	29.8	3.0	32.8	3.3
218	23.4	3.5	26.4	3.9	29.3	4.4	32.2	4.8



DP-448-P

Maximum Flow: 44.9 GPM	Suction Hose Diameter: 2" Hose
Maximum Pressure: 218 PSI	Discharge Hose Diameter: 1" NPT
Maximum Speed: 550 RPM	Max Temperature: 140°F
Maximum Power: 6.5 HP	Lubricating Oil Type: 30 SAE
Weight: 58 lbs.	Through shaft: 1 3/8" 6-spline both ends
Diaphragms: 4	
Negative Pressure - Max: 4.9 ft.	
Intermittent: 9.8 ft.	

DP-448-P Performance - RPM								
Pressure	400		450		500		550	
	GPM	HP	GPM	HP	GPM	HP	GPM	HP
29	32.7	0.6	36.7	0.7	40.8	0.8	44.9	0.9
73	32.5	1.6	36.5	1.8	40.6	2.0	44.6	2.2
145	32.1	3.2	36.1	3.6	40.1	4.0	44.1	4.4
218	31.7	4.7	35.7	5.3	39.6	5.9	43.6	6.5

Recommended control unit:

- SC-2660-3



Recommended control unit:

- SC-2660-3

DP-555-P

Maximum Flow: 55.5 GPM	Suction Hose Diameter: 2" Hose
Maximum Pressure: 218 PSI	Discharge Hose Diameter: 1" NPT
Maximum Speed: 550 RPM	Max Temperature: 140°F
Maximum Power: 8.0 HP	Lubricating Oil Type: 30 SAE
Weight: 73 lbs.	Through shaft 1 3/8" 6-spline opposite end
Diaphragms: 5	
Negative Pressure - Max: 4.9 ft.	
Intermittent: 9.8 ft.	

DP-555-P Performance - RPM								
Pressure	400		450		500		550	
	GPM	HP	GPM	HP	GPM	HP	GPM	HP
29	40.4	0.8	45.4	0.9	50.4	1.0	55.5	1.1
73	40.0	2.0	45.0	2.2	50.0	2.5	55.0	2.7
145	39.6	3.9	44.5	4.4	49.5	4.9	54.4	5.4
218	39.2	5.8	44.1	6.6	49.0	7.3	53.9	8.0



Recommended control unit:

- SC-2660-3

DP-687-P

Maximum Flow: 68.7 GPM	Suction Hose Diameter: 2" Hose
Maximum Pressure: 218 PSI	Discharge Hose Diameter: 1 1/4" NPT
Maximum Speed: 550 RPM	Max Temperature: 140°F
Maximum Power: 9.4 HP	Lubricating Oil Type: 30 SAE
Weight: 86 lbs.	Through shaft 1 3/8" 6-spline opposite end
Diaphragms: 6	
Negative Pressure - Max: 4.9 ft.	
Intermittent: 9.8 ft.	

DP-687-P Performance - RPM								
Pressure	400		450		500		550	
	GPM	HP	GPM	HP	GPM	HP	GPM	HP
29	50.0	1.0	56.2	1.1	62.4	1.2	68.7	1.4
73	49.6	2.5	55.8	2.8	62.0	3.1	68.2	3.4
145	48.8	4.8	54.9	5.5	61.0	6.1	67.1	6.7
218	48.0	7.2	54.0	8.0	60.0	8.9	66.1	9.8

MEDIUM-PRESSURE DIAPHRAGM PUMPS

MEDIUM PRESSURE DIAPHRAGM PUMP FEATURES:

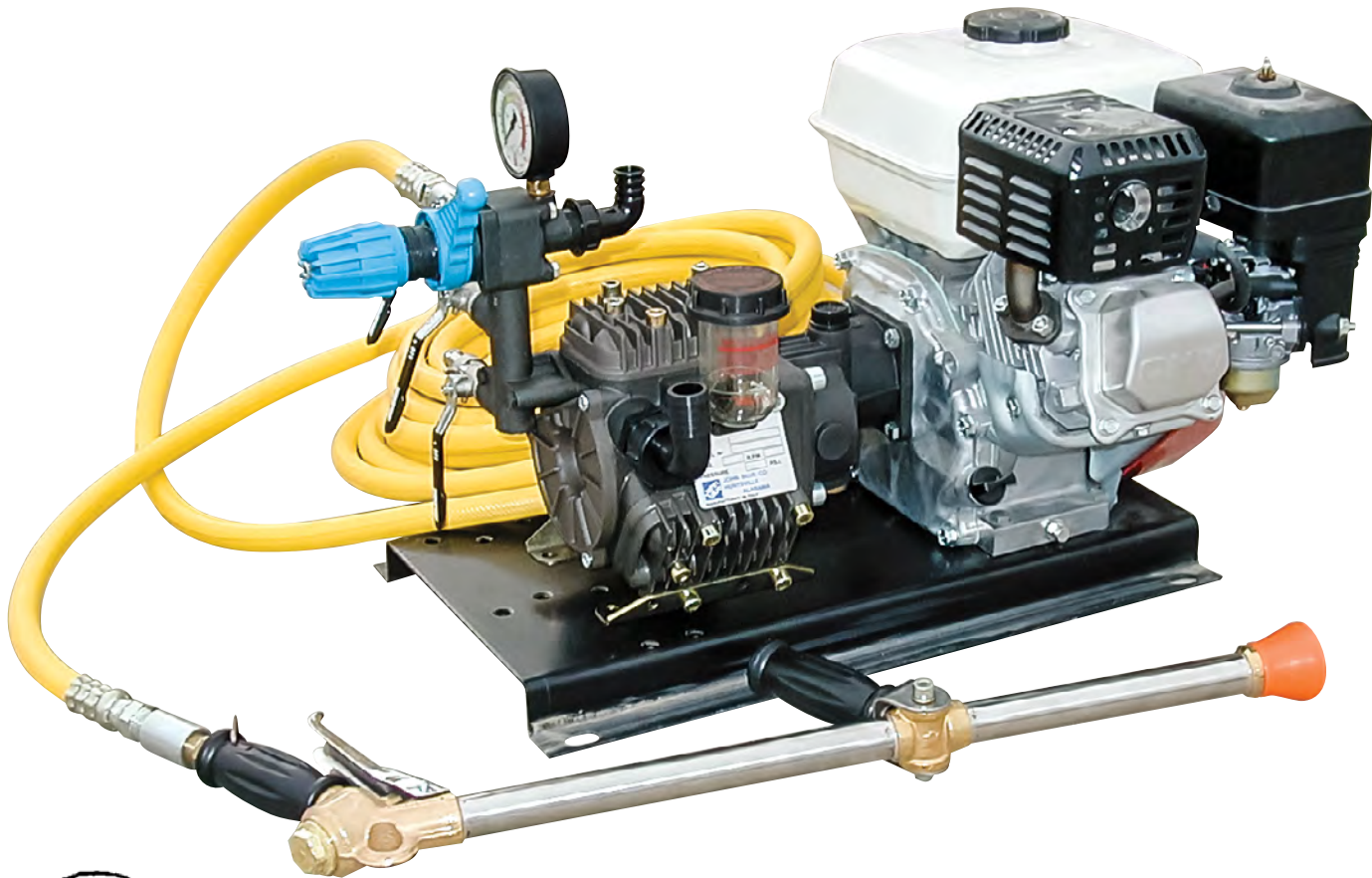

Each piston has two piston rings for improved piston seal to keep a film of oil between the piston and diaphragm.

BENEFITS:

- Ball bearings on the crankshaft for increased life.
- Features a uniquely shaped piston to reduce wear against the diaphragm.
- Medium Pressure Diaphragm Pumps perform from 7.4 to 18.5 GPM with pressure ratings from 0 to 580 PSI.
- The pump's design delivers high volumetric efficiencies and more pumping capacity.
- Three-piston semi-hydraulic diaphragm pumps ensure a smoother, quieter operation.
- Convenient visual oil-level indicator.
- Pumps can be run dry.

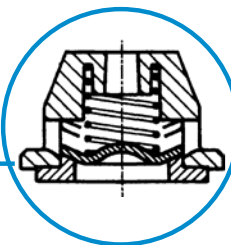
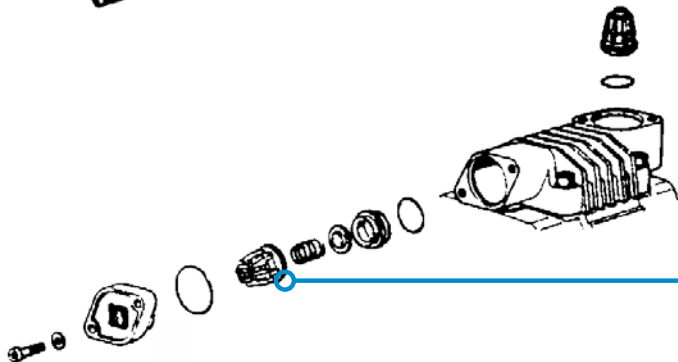

Exclusive stainless steel check valve design ensures perfect sealing performance due to its unique spherical shaped poppet and conical seat.



DP-74.1

Maximum Flow: 7.4 GPM	Suction Hose Diameter: 1" Hose
Maximum Pressure: 580 PSI	Discharge Hose Diameter: ½" NPT
Maximum Speed: 550 RPM	Max Temperature: 140°F
Maximum Power: 2.5 HP	Lubricating Oil Type: 30 SAE
Weight: 16 lbs.	Can be PTO mounted, gasoline engine,
Diaphragms: 3	hydraulic motor or electric motor driven

Optional Models:

DP-74.1-GRI Includes gearbox for 3.5 and 5 HP engines and SC-1132-2 regulator.

Recommended Accessories:

- Pressure regulator: SC-1132-2 or SC-1240-3.
- Gearbox for 3.5 and 5 HP engines: DP-321009.
- Pump equipped with crankshaft flange, must order shaft separately: DP-318793 (¾") solid shaft or DP-318590 (1") solid shaft.

Optional Accessories:

- DP-318343** Female 1 3/8" shaft kit
- DP-310049** Male 1 3/8" shaft kit
- DP-31874897** Hydraulic adaptor kit SAE "B"

DP-74.1 Performance - RPM								
Pressure	500		550		600		650	
	GPM	HP	GPM	HP	GPM	HP	GPM	HP
29	6.70	0.14	7.40	0.16	8.00	0.17	8.70	0.18
145	6.50	0.70	7.10	0.77	7.66	0.80	8.20	0.88
290	6.30	1.37	7.00	1.5	7.50	1.60	8.10	1.75
580	6.20	2.0	6.90	2.2	7.40	2.4	7.90	2.5



DP-90.1

Maximum Flow: 9 GPM @ 550 RPM, 10.6 GPM @ 650 RPM	Suction Hose Diameter: 1" Hose
Maximum Pressure: 580 PSI	Discharge Hose Diameter: ½" NPT
Maximum Speed: 650 RPM	Max Temperature: 140°F
Maximum Power: 4.0 HP	Lubricating Oil Type: 30 SAE
Weight: 17 lbs.	Can be PTO mounted, gasoline engine,
Diaphragms: 3	hydraulic motor or electric motor driven.

Optional Models:

DP-90.1-GRI Includes gearbox for 3.5 and 5 HP engines and SC-1132-2 regulator.

Recommended Accessories:

- Pressure regulator: SC-1132-2 or SC-1240-3.
- Gearbox for 3.5 and 5 HP engines: DP-321009.
- Pump equipped with crankshaft flange, must order shaft separately: DP-318793 (¾") solid shaft or DP-318590 (1") solid shaft.

Optional Accessories:

- DP-318343** Female 1 3/8" shaft kit
- DP-310049** Male 1 3/8" shaft kit
- DP-31874897** Hydraulic adaptor kit SAE "B"

DP-90.1 Performance - RPM								
Pressure	500		550		600		650	
	GPM	HP	GPM	HP	GPM	HP	GPM	HP
29	8.2	0.12	9.0	0.14	9.8	0.15	10.6	0.15
290	7.7	1.2	8.5	1.3	9.2	1.4	9.8	1.5
435	7.5	1.7	8.3	1.9	9.1	2.1	9.6	2.2
580	7.4	2.4	8.2	2.5	9.0	2.8	9.5	2.9



DP-139

Maximum Flow: 13.9 GPM @ 550
and 145 PSI

Maximum Pressure: 580 PSI

Maximum Speed: 550 RPM

Maximum Power: 5.6 HP

Weight: 31 lbs.

Diaphragms: 3

Suction Hose Diameter: 1 ¼" Hose

Discharge Hose Diameter: ½" NPT

Max Temperature: 140°F

Lubricating Oil Type: 30 SAE

Optional Models:

DP-139-GRI

Includes gearbox to fit 3.5 and 5 HP engines and SC-1132-2 regulator

Optional Accessories:

DP-31874897

Hydraulic adaptor kit SAE "B"

Recommended Accessories:

- Pressure regulator: SC-1241-2 or SC-1240-3.
- Gearbox for 3.5 and 5 HP engines: DP-321009 and DP-321006 for 8 and 11 HP engines.
- Pump has crankshaft flange on one side, 1 3/8" spline shaft opposite side, must order solid shaft separately: DP-318793 (3/4") solid shaft or DP-318590 (1") solid shaft.

DP-139 Performance - RPM								
Pressure	400		450		500		550	
	GPM	HP	GPM	HP	GPM	HP	GPM	HP
145	10.04	1.05	11.30	1.19	12.55	1.32	13.90	1.46
290	10.04	2.11	11.30	2.38	12.55	2.64	13.70	2.89
435	9.93	3.13	11.17	3.53	12.40	3.92	13.60	4.30
580	9.80	4.13	11.04	4.64	12.28	5.17	13.50	5.60

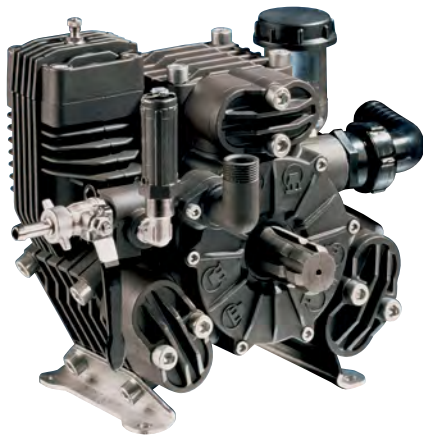

DP-185.1

Maximum Flow: 18.5 GPM @ 145 PSI

Maximum Pressure: 580 PSI

Maximum Speed: 550 RPM

Maximum Power: 7.4 HP

Weight: 33 lbs.

Diaphragms: 3

Suction Hose Diameter: 1 ¼" Hose

Discharge Hose Diameter: ¾" NPT

Max Temperature: 140°F

Lubricating Oil Type: 30 SAE

Optional Models:

DP-185.1-GRI

Includes gearbox to fit 8 and 11 HP engines and SC-1240-3 regulator

Optional Accessories:

DP-31874897

Hydraulic adaptor kit SAE "B"

Recommended Accessories:

- Pressure regulator: SC-1240-3.
- Gearbox DP-321006 for 8 and 11 HP engines.
- Pump has crankshaft flange on one side, 1 3/8" spline shaft opposite side, must order solid shaft separately: DP-318793 (3/4") solid shaft or DP-318590 (1") solid shaft.

DP-185.1 Performance - RPM								
Pressure	400		450		500		550	
	GPM	HP	GPM	HP	GPM	HP	GPM	HP
145	13.79	1.4	15.30	1.6	16.90	1.7	18.50	1.9
290	13.47	2.8	15.00	3.16	16.60	3.5	18.20	3.8
435	13.20	4.1	14.80	4.6	16.40	5.1	17.90	5.6
580	12.90	5.4	14.50	6.1	16.10	6.7	17.70	7.4



1

2

3

4

5

6

7

HIGH-PRESSURE DIAPHRAGM PUMPS

HIGH PRESSURE DIAPHRAGM PUMP FEATURES

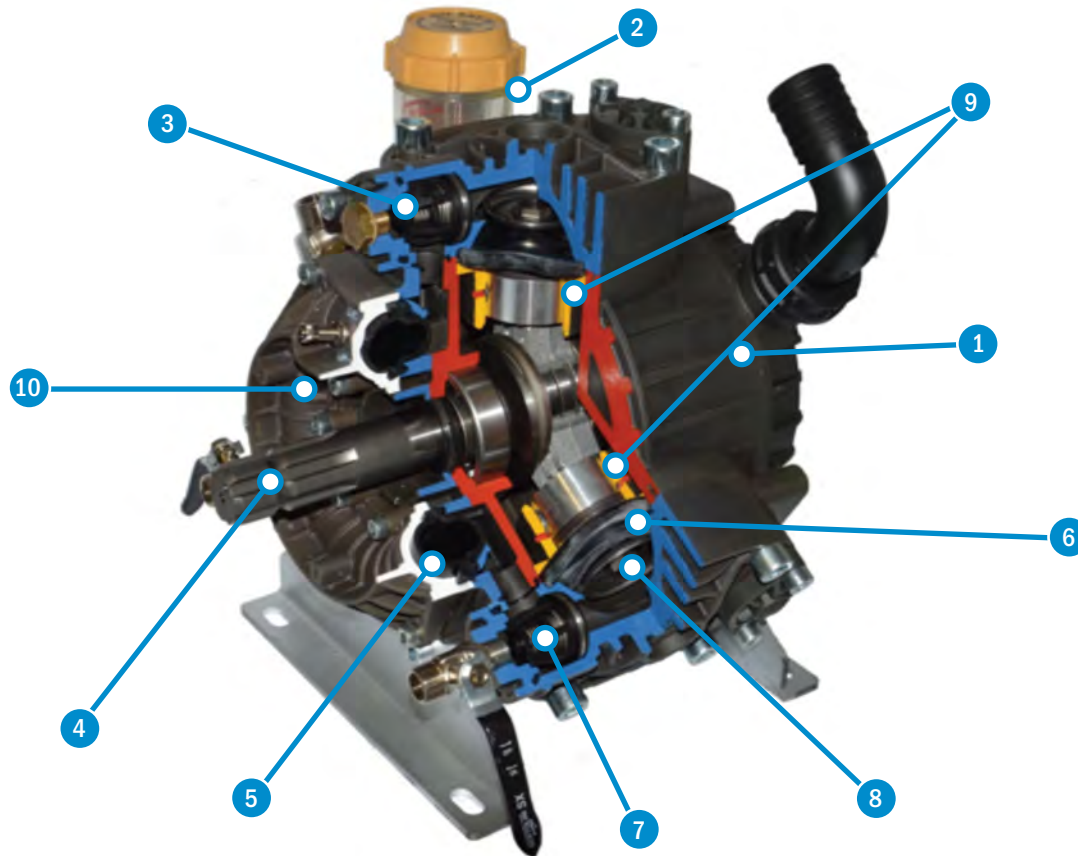

1. Oversized, separate suction and pressure circuits create a smooth flow of the liquid product with no pressure loss.
2. Convenient visual oil tank fitted with matched diaphragm to ensure correct oil level.
3. Check valves can be serviced easily, minimum maintenance.
4. Crankshaft stroke reduced, which increases diaphragm life because diaphragms are not stressed.
5. Unique pulsation damper system provides dampening on 32 circuits instead of one, which reduces vibrations and allows for smoother operation.
6. Four diaphragm material options are available, contact factory.
7. Special check valve design: unique spherical shaped poppet and conical seat made of 316 stainless steel, delivering high volumetric efficiencies.
8. Pre-set diaphragm bolt and diaphragm washer are made from 316 stainless steel. This exclusive feature ensures chemical resistance and longer life of the pump.
9. Two piston rings for each piston, this exclusive design increases diaphragm efficiency.
10. Parts in contact with chemical products are constructed with die-cast aluminum, covered with special corrosion proof treatment.



DP-291.1

Maximum Flow: 29.1 GPM @ 29 PSI	Suction Hose Diameter: 1 1/2" Hose
Maximum Pressure: 725 PSI	Discharge Hose Diameter: 3/4" NPT
Maximum Speed: 550 RPM	Max Temperature: 140°F
Maximum Power: 14	Lubricating Oil Type: 30 SAE
Weight: 56 lbs.	Through shaft with 1 3/8" spline both ends.
Diaphragms: 3	

Recommended Accessories:

- Pressure regulator: SC-1480-3

Optional Models:

DP-291.1-GRI Includes gearbox for 1" shaft engines and SC-1480-3 regulator

DP-291.1 Performance - RPM								
Pressure	400		450		500		550	
	GPM	HP	GPM	HP	GPM	HP	GPM	HP
29	21.1	0.4	23.8	0.5	26.4	0.5	29.1	0.6
290	20.9	4.1	23.5	4.7	26.1	5.2	28.7	5.7
580	20.6	8.2	23.2	9.2	25.7	10.2	28.3	11.2
725	20.4	10.1	22.9	11.4	25.5	12.6	28	13.9



DP-407.2

Maximum Flow: 40.7 GPM	Suction Hose Diameter: 1 1/2" Hose
Maximum Pressure: 725 PSI	Discharge Hose Diameter: 3/4" NPT
Maximum Speed: 550 RPM	Max Temperature: 140°F
Maximum Power: 20.1 HP	Lubricating Oil Type: 30 SAE
Weight: 79 lbs.	Through shaft with 1 3/8" spline both ends.
Diaphragms: 4	

Recommended Accessories:

- Pressure regulators: SC-1480-3 and SC-1580-1

Optional Models:

DP-407.2-GRI Includes gearbox for 1" shaft engines and SC-1580-1 regulator

DP-407.2-VP Has 35mm input shaft for use with DP-321054 gearbox reduction kit

DP-407.2 Performance - RPM								
Pressure	400		450		500		550	
	GPM	HP	GPM	HP	GPM	HP	GPM	HP
29	29.6	0.6	33.3	0.7	37.0	0.7	40.7	0.8
290	28.8	5.7	32.4	6.4	36.0	7.2	39.6	7.9
580	28.4	11.3	32.0	12.7	35.5	14.1	39.1	15.5
725	28.2	14.0	31.8	15.8	35.3	17.5	38.8	19.3

SPRAY CONTROL VALVES

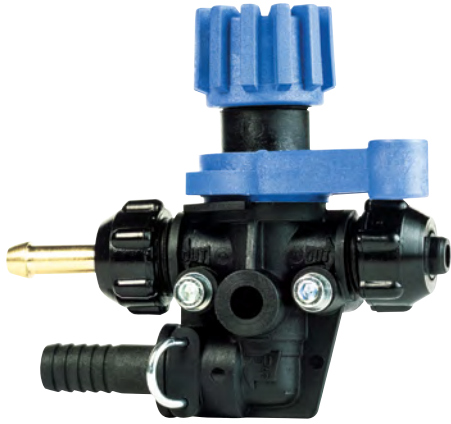

SC-1066-2 SERIES

Flow Rate - 6.6 GPM	By-Pass Hose Diameter - 1/2" Hose
Maximum Pressure - 290 PSI	Discharge Pressure Hose Diameter - 3/8" Hose
Unit Weight - 4 lbs	

The Pressure Regulator model SC-1066-2 can be mounted directly to DP-43 Series Low Pressure Diaphragm Pumps. The SC-1066-2 is designed to adjust to the liquid flow from the pump. Maximum operating pressure is 290 PSI. It is constructed from polypropylene for excellent corrosion resistance. The valve, with double seals improves liquid velocity. This manual regulator is equipped with a main shut off/bypass lever, it is fitted for a port for a pressure gauge (optional) and has 1/2" NPT inlet and (2) 3/8" outlet barbs.



SC-1132-2 SERIES

Flow Rate - 13.2 GPM	By-Pass Hose Diameter - 3/4" Hose
Maximum Pressure - 600 PSI	Discharge Pressure Hose Diameter - 3/8" Hose
Unit Weight - 2 lbs	

Pressure Regulator model SC-1132-2 can be fitted directly to the pump or remote mounted. Used with DP-70 Poly Series and DP-74.1 Series Medium pressure pumps. It is designed to provide gradual and smooth regulation of pressure up to 600 PSI. The body is manufactured from reinforced plastic material with extra large valve passages to minimize pressure loss. A diaphragm seals off operating parts from contact with chemicals, which provides vibration resistance. Modular regulation, the glycerine filled pressure gauge is included. The remote control kit (available separately) is equipped with an inlet threaded connector 1/2" gas, straight or 90° to fit hosetails from 10 to 19 mm. The manual bypass shut off lever is included. Available with two adjustable discharge ball valves on/off 1/2" gas threads.

Recommended Accessories:

- DP-318911: Remote Mounting Kit

**Recommended Accessories:**

- DP-318785: Remote mounting kit, 1/2" NPT inlet
- DP-318786: Remote mounting kit, 3/4" NPT inlet
- DP-318788: Remote mounting kit, 1/2" NPT 90°
- DP-318921: Remote mounting kit, 3/4" NPT inlet

SC-1240-3 SERIES

Flow Rate - 24.0 GPM

Suction Hose Diameter - 3/4" NPT

Maximum Pressure - 725 PSI

Discharge Pressure Hose Diameter - 1/2" NPT

Unit Weight - 5 lbs

The Pressure Regulator model SC-1240-3 can be mounted directly or remote mounted to pumps DP-74.1, DP-139, and DP-185.1. The SC-1240-3 is designed to provide gradual and smooth regulation of pressures up to 725 PSI. The inlet body is constructed of aluminum with extra large passages, which helps to keep to a minimum pressure loss. The Buna-N diaphragm prevents the operating parts from coming into contact with the chemicals being applied, improving vibration resistance. The SC-1240-3 is equipped with a complete quick by-pass lever, pressure gauge, 3/4" NPT inlet and (3) 1/2" outlets.

**Recommended Accessories:**

- DP-318911: Remote Mounting kit

SC-1241-2 SERIES

Flow Rate - 24.0 GPM

By-Pass Hose Diameter - 3/4" NPT

Maximum Pressure - 580 PSI

Discharge Pressure Hose Diameter - 3/8" Hose

Unit Weight - 4 lbs

The Sting Pressure Regulator model SC-1241-2 can be mounted directly or remotely to DP-74.1, DP-90.1 and DP-139. The Sting valve has an ergonomic adjusting knob resulting in gradual and smooth regulation of pressures up to 580 PSI. The manual by-pass/shut off lever is designed to shut off pressure and for immediate start-up. The valve body is constructed of heavy-duty polyamide. The valve seat and poppet are made of ceramic that helps to ensure a long life, even with aggressive chemicals. The SC-1241-2 is equipped with a pressure gauge and (2) 3/8" hose bars.



SC-1480-3 SERIES

Flow Rate - 48.0 GPM	Suction Hose Diameter - 3/4" NPT
Maximum Pressure - 725 PSI	Discharge Pressure Hose Diameter - 1/2" NPT
Unit Weight - 5 lbs	

Pressure Regulator model SC-1480-3 can be mounted directly to the DP-407.2 or DP-291-B or remote mounted to pumps with large flow rates up to 48 GPM. The SC-1480-3 is designed to provide gradual and smooth regulation of pressures up to 725 PSI. The inlet body is constructed of aluminum with extra large passages, which helps to keep to a minimum pressure loss and to handle large volumes. The SC-1480-3 is equipped with a complete quick by-pass lever, pressure gauge, 3/4" NPT inlet and (3) 1/2" hose barb outlets.

Recommended Accessories:

- DP-318788: Remote mounting kit, 1/2" NPT 90°
- DP-318921: Remote mounting kit, 3/4" NPT inlet



SC-1580-1 SERIES (REPLACES THE SC-1480-1)

Flow Rate - 58.0 GPM	Suction Hose Diameter - 3/4" NPT
Maximum Pressure - 1015 PSI	Discharge Pressure Hose Diameter - 3/4" Hose
Unit Weight - 5 lbs	

The SC-1580-1 has a brass alloy body, parts in contact with spray materials are stainless steel and the poppet is ceramic, which offers a high resistance against chemical attack. The SC-1580-1 can be used with the DP-407.2.

SC-2420-3 SERIES

Flow Rate - 42.0 GPM	Suction Hose Diameter - 1" Hose
Maximum Pressure - 290 PSI	Discharge Pressure Hose Diameter - 3/4" NPT
Unit Weight - 8 lbs	

The remote control poly spray valve model SC-2420-3 is recommended for all pumps with flow rates less than 40 GPM (see pressure restrictions). The SC-2420-3 includes (3) 3/4" outlets with individual shut-off and a ball valve main shut-off. A pressure relief valve is included. Three outlets come standard on the SC-2420-3, extra modular outlets are available separately through seven sections.

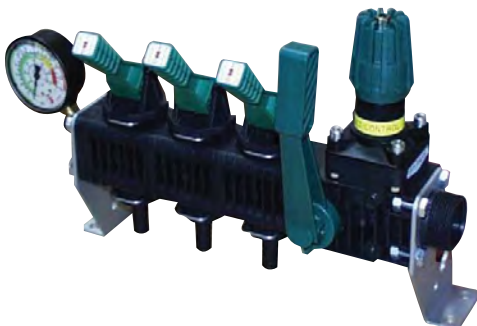



- » Volumetric Control
- » Exclusive Anti-Drip Feature

SC-2660-3 SERIES

Flow Rate - 66.0 GPM

Suction Hose Diameter - 1" Hose

Maximum Pressure - 145 PSI

Discharge Pressure Hose Diameter - ½" NPT

Unit Weight - 18 lbs

The SC-2660-3 is a poly remote control valve with a **volumetric control**, which maintains the spray rate per acre at varying ground speeds when using a ground speed controlled positive displacement pump. The volume per acre is constant; pressure will vary as ground speed varies.

Each boom section has a metered bypass system to allow an individual boom section to be closed without adjusting the **volumetric control valve**. This control valve has a ball valve main shut-off, which provides a positive shut-off. The SC-2660-3 control valve has an **exclusive anti-drip** system that prevents the nozzles from dripping when the main shut-off is closed. There is no need for nozzle check valves.

SPRAY GUNS

The SC-0400 spray gun has two possible spray adjustments. By operating the handle it controls the spray angle from cone spray to a straight stream.



The SC-1300 is a stainless steel washing spray gun.



Miscellaneous Kits	
Model Number	Description
DP-318911	Remote Mount Kit for SC-1132-2, ½" NPT Inlet
DP-318785	Remote Mount Kit for SC-1240-3, ½" NPT inlet
DP-318786	Remote Mount Kit for SC-1240-3 and SC-1480-3, ¾" NPT inlet
DP-318788	Remote Mount Kit for SC-1240-3, 90°, ½" NPT inlet
DP-318921	Remote Mount Kit for SC-1240-3 and SC-1480-3, 90°, ¾" 80NPT inlet
DP-321003	Gearbox for DP-193-PP and DP-280-PP, use with 1" pump shaft and ¾" engine shaft. Must use (1) DP-31155907 spacer and (4) DP-86357500 bolts when using DP-282-P and DP-332-P.
DP-321006	6:1 Gearbox Reduction Kit for DP-139, DP-185.1, fits 8 and 11 HP gasoline engines
DP-321009	6:1 Gearbox Reduction Kit for DP-43, DP-70, DP-74.1, DP-139, and DP-185.1, fits 3.5 and 5 HP gasoline engines
DP-321054	6:1 Gearbox reduction kit for DP-407.2-VP, fits 20+ HP engines with 1" shaft
DP-318343	1 ³⁄₈" Female Shaft Kit for DP-43-FP, DP-74.1, and DP-124
DP-310049	1 ³⁄₈" Male PTO Shaft Kit for DP-74.1 and DP-124
DP-318793	¾" Solid Shaft Kit for DP-43, DP-70, and DP-74.1
DP-318590	1" Solid Shaft Kit
DP-31874897	SAE "B" Hydraulic Adapter for DP-43, DP-70, DP-74.1, DP-124, and DP-139
DP-31874997	SAE "B" Hydraulic Adapter for DP-280-1, DP-280-PP, DP-193-PP, DP-282-P, and DP-332-P
DP-31922897	SAE "A" Hydraulic Adapter for DP-193-PP
DP-318086	PTO Kit for Diaphragm Pump

Model Number	Repair Kit	Valve Kit
DP-43.1-GRIP, DP-43.1-GRIP2.2, DP-43-FP, DP-43.1-GRP	DP-94991297	DP-94991697
DP-70-P, DP-70-FP, DP-70.1-GRIP, DP-70.1-GRP	DP-94994297	DP-94994497
DP-193-PP, DP-193-GRP, DP-193-GRIP	DP-63988197	DP-639872973
DP-282-P, DP-282.1-P, DP-332-P	DP-62981097	DP-62980597
DP-448-P	DP-28989397	DP-28988597
DP-555-P	DP-55980997	DP-55980397
DP-687-P	DP-14988997	DP-14987697
DP-74.1, DP-74.1-GRI	DP-03987497	DP-03987597
DP-90.1, DP-90.1-GRI	DP-03987497	DP-03987597
DP-139, DP-139-GRI	DP-23989097	DP-23989197
DP-185.1, DP-185.1-GRI	DP-23989297	DP-23989197
DP-392.1	DP-41989297	DP-41987097
DP-407.1	DP-41990597	DP-41987097
DP-291.1, DP-291.1-GRI	DP-35988297A	DP-35987097
DP-407.2, DP-407.2-GRI, DP-407.2-VP	DP-41990597A	DP-41987097
DP-605.2-P	DP-14989397	DP-14987697
DP-230.1	DP-35988097	DP-35987097

Diaphragm Pump Conversion Kits for DP-43-GRP and DP-193-PP

Model Number	Description
115559-91	Electric Motor Conversion Kit for pumps with a gearbox. For use with DP-43.1-GRIP, DP-43.1-GRP, DP-70-GRI, and DP-74.1-GRI only.
116235-91	*DP conversion kit with motor, 3450 RPM, 1 ph
116236-91	*DP conversion kit with motor, 1725 RPM, 1 ph
116237-91	*DP conversion kit with motor, 3450 RPM, 3 ph
116238-91	*DP conversion kit with motor, 1725 RPM, 3 ph
116231-01	Motor only, 1 HP, 3450 RPM, 1 ph
116232-01	Motor only, 1 HP, 1725 RPM, 1 ph
116233-01	Motor only, 1 HP, 3450 RPM, 3 ph
116234-01	Motor only, 1 HP, 1725 RPM, 3 ph

Optional Diaphragm Pump Adapters

Model Number	Description
116447-91	3/4" npt ss outlet adapter kit (fits all pumps that mention the SC-1132-2 & SC-1240-3 regulators)
116444-01	3/4" G. male to 3/4" npt male adapter - Stainless Steel
116445-01	3/4" G. male to male adapter - Stainless Steel
116446-01	3/4" G. fem. coupling - Stainless Steel

*Conversion kit includes motor (with 3/4" shaft, 56C, TEFC, 60 HZ), flange adapter, 3/18-16 SHCS, 5/16-18 x 3/4 SHCS, 5/16 lock washer, 3/8 lock washer.







ANHYDROUS AMMONIA PRODUCTS

John Blue provides innovative products for applying and monitoring anhydrous ammonia. The Impellicone® Anhydrous Ammonia Flow Dividers, developed in collaboration with Iowa State University, are available in three models. These patented dividers ensure precise distribution of anhydrous ammonia. Additionally, John Blue offers precision Impellicone® Splitters for use when three or more dividers are plumbed in parallel, maintaining even distribution of liquid and gas across all sections.

5 ANHYDROUS AMMONIA PRODUCTS

Impellicone® Flow Dividers and Splitters. 73
NH3 VisaGage II with LBMS. 74-75
Knives 76



IMPELLICONE® FLOW DIVIDER

IMPELLICONE® DISTRIBUTES NH₃ TO MULTIPLE ROWS WHILE GREATLY REDUCING THE OVER APPLICATION OF NH₃

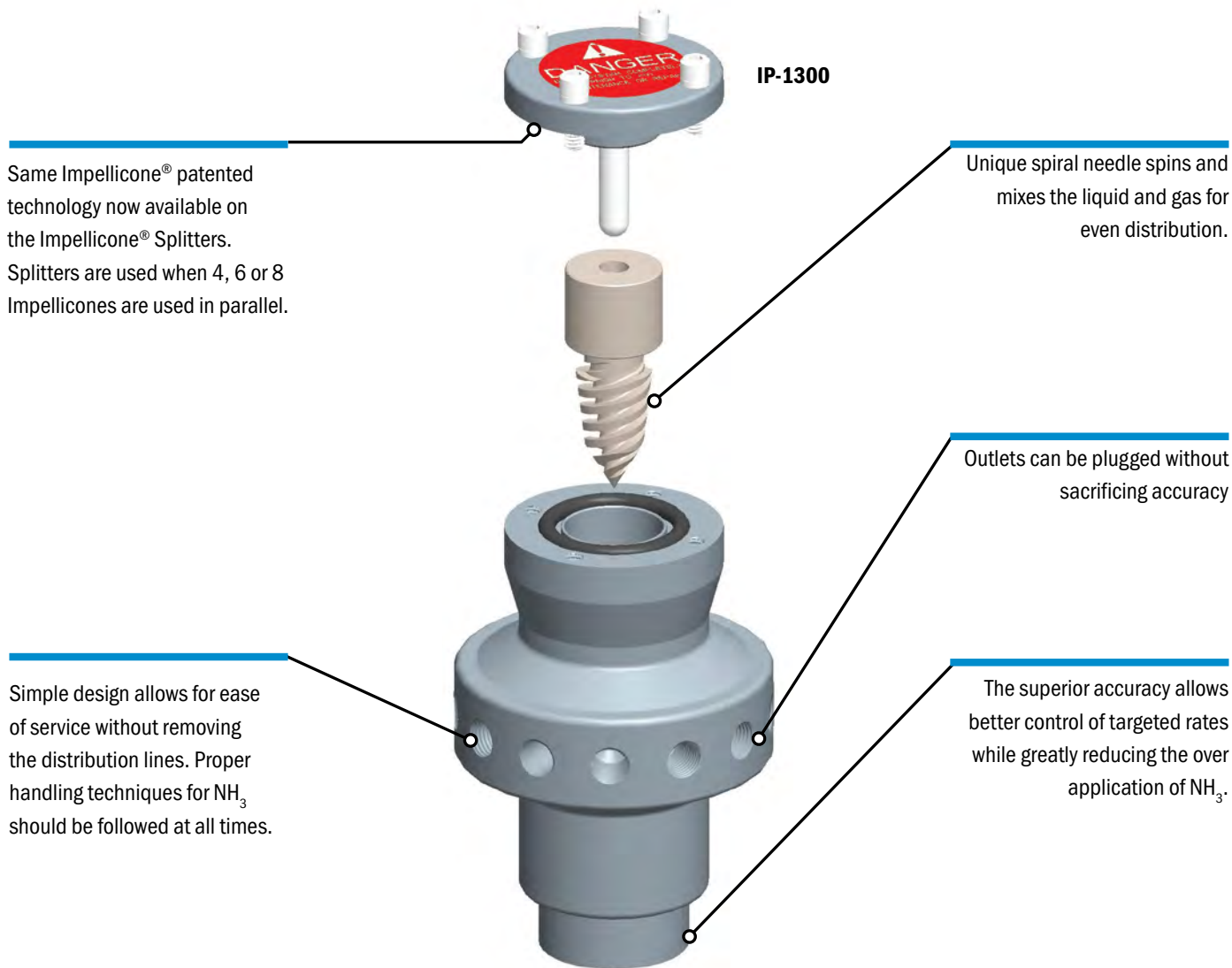

Impellicone® Flow Dividers, Splitters, and Manifolds

Part Number	Description	Number of Outlets	Inlet Size	Outlet Size
IP-0600	6 Outlet NH ₃ Flow Divider	6	1" NPT	¼" NPT
IP-1300	13 Outlet NH ₃ Flow Divider	13	1" NPT	¼" NPT
IP-1800	18 Outlet NH ₃ Flow Divider	18	1" NPT	¼" NPT
IPS2-4	4 Port Impellicone® Splitter	4	1 ¼" NPT	1" NPT
IPS2-6	6 Port Impellicone® Splitter	6	1 ¼" NPT	1" NPT
IPS2-8	8 Port Impellicone® Splitter	8	1 ½" NPT	1" NPT
113989	Manifold Mount			
113983	Plain Manifold, Inlet Flow Diffuser, 304 SS	12	1" FPT	¼" FPT

NH₃ VISAGAGE WITH LBMS

FEATURES OF NH₃ VISAGAGE II WITH LIQUID BLOCKAGE MONITOR SYSTEM (LBMS)

- Monitor NH₃ or N-Serve flow rates from the tractor cab.
- The NH₃ VisaGage is manufactured from polymethylpentene (TPX®) chemical resistant bodies with UV protection, polypropylene balls and ball screen, Buna-N o-rings and aluminum manifolds.
- Maximum allowed pressure in the monitor is 100 PSI.
- NH₃ VisaGage available in 2 and 4 row units.
- Mount the NH₃ VisaGage to a sensor, which identifies where the magnetic balls are floating in each row during application.
- Shows low and no-flow, plus the premium wireless systems show high flow.
- Each row with a problem will be highlighted by a flashing LED light at the row. No need to remember or search for the blocked row when you come to a stop.
- See a visual display and hear an audible alarm on the control panel in the tractor cab when there is a problem row.
- Alarm will reset automatically when the blockage has been corrected.
- Correct problems immediately or pause to capture the row for investigation later.
- Our patented LBMS is available in five user-friendly options: standard wired control panel, iPad, Android or Amazon Kindle wireless system, and ISOBUS.



NH₃ VisaGage with Liquid Blockage Monitor System (LBMS)

Part Number	Description
SMFD2-NH ₃	2 Row NH ₃ VisaGage
SMFD4-NH ₃	4 Row NH ₃ VisaGage
BMi-08*	Premium 8 Row Wireless Liquid Blockage Monitor System for NH ₃ , includes ram mounting bracket, input harness, 28 ft. extension harness, wireless sensor kit, standard sensor kit and two terminator plugs.
BM-08AP*	Wired Standard Control Panel 8 Row Liquid Blockage Monitor System for NH ₃ , includes control panel with mount bracket, input harness, 28 ft. extension harness, tee harness, two standard sensor kits and two terminator plugs.
BM-08PL*	Wired Standard Control Panel 8 Row Liquid Blockage Monitor System for NH ₃ , includes control panel with mount bracket, input harness, 28 ft. extension harness, tee harness, two standard sensor kits, two terminator plugs and two 15 ft. extension harnesses.
BM-08ISO (Universal Kit) / BM-08ISO-JD (John Deere®)	ISOBUS 8 row Liquid Blockage Monitor System for NH ₃ , includes main computer harness, job computer, tap harness (universal or brand specific), tee harness, two 15 ft. extension harnesses, two standard sensor kits and two terminator plugs. For use with GS2 and GS3.

* See pages 28-32 for more Liquid Blockage Monitor System details.



NEW LBMS ENHANCEMENTS

New and improved features for Liquid Blockage Monitor System!
See Page.....28





A-720C-4S



A-460 BC

A-SERIES STAINLESS STEEL TUBES ON HEAVY DUTY KNIVES

- Heat-treated after coating to assure strength and wearability.
- High carbon 1080 steel makes the knife strong and tough.
- Plain tube or 304 stainless steel tube.
- Available with extremely hard boride coating for long wear life.
- Largest toe section on any knife in the industry.

NH ₃ Liquid Blades						
Part Number	Blade Type	Number of Tubes	Tube Material	Tube Size	Sealer	Boride Coating
A-460BC-3	Back Swept	Single	Stainless Steel	3/8"	No	Yes
A-460BC-3S	Back Swept	Single	Stainless Steel	3/8"	Yes	Yes
A-460BC-3SP	Back Swept	Single	Plain	3/8"	Yes	Yes
A-460BC-4	Back Swept	Single	Stainless Steel	1/2"	No	Yes
A-460BC-4P	Back Swept	Single	Plain	1/2"	No	Yes
A-720-3	Front Swept	Single	Stainless Steel	3/8"	No	Yes
A-720-3P	Front Swept	Single	Plain	3/8"	No	No
A-720-3S	Front Swept	Single	Stainless Steel	3/8"	Yes	No
A-720-3SP	Front Swept	Single	Plain	3/8"	Yes	No
A-720-4	Front Swept	Single	Stainless Steel	1/2"	No	No
A-720-4P	Front Swept	Single	Plain	1/2"	No	No
A-720-4S	Front Swept	Single	Stainless Steel	1/2"	Yes	No
A-720-4SP	Front Swept	Single	Plain	1/2"	Yes	No
A-720C-3	Front Swept	Single	Stainless Steel	3/8"	No	Yes
A-720C-3P	Front Swept	Single	Plain	3/8"	No	Yes
A-720C-3S	Front Swept	Single	Stainless Steel	3/8"	Yes	Yes
A-720C-3SP	Front Swept	Single	Plain	3/8"	Yes	Yes
A-720C-4	Front Swept	Single	Stainless Steel	1/2"	No	Yes
A-720C-4P	Front Swept	Single	Plain	1/2"	No	Yes
A-720C-4S	Front Swept	Single	Stainless Steel	1/2"	Yes	Yes
A-720C-4SP	Front Swept	Single	Plain	1/2"	Yes	Yes
AD-720C	Front Swept	Dual	Stainless Steel	(1) 3/8" front & (1) 1/2" rear	No	Yes
AD-720C-3	Front Swept	Dual	Stainless Steel	3/8"	No	Yes
AD-720C-4	Front Swept	Dual	Stainless Steel	1/2"	No	Yes



SPECIALTY PRODUCTS PUMPS, FOAM MARKERS, & CONTROLLERS

John Blue Company offers a range of specialty pumps and foam markers guaranteed to perform. Our Brass Gear Pumps, handle high-viscosity materials with ease. John Blue Foam Markers serve as reliable primary or secondary guidance systems, producing long-lasting foam balls - ideal for golf, turf, and agricultural spraying applications. The John Blue 12-Volt Pump is the most dependable, weatherproof 12-Volt diaphragm pump on the market, protected against dust and overspray. Our 12-Volt Batch Controller accurately meters low-volume fluid on any brand pump, perfect for farm, lawn, and co-op use.

SPECIALTY PRODUCTS

Brass Gear Pumps77
Foam Markers.....78-80
12-Volt Pump and Accessories81
12-Volt Batch Controller81
12-Volt Speed Controllers.....82





BRASS GEAR PUMP

This positive displacement brass gear pump with the shear pin design and stainless steel shaft is ideal for sprayer applications. The John Blue Brass Gear Pump maintains even pressure and is designed to be run at 540-600 RPM.

Shear Pin Design	Solid Brass Cover Plate
Inlet - 1 1/4"	Maximum Pressure - 250 PSI
Solid Brass Pump Case	Maximum Capacity - 18 GPM
Outlet - 1 1/4"	Maximum Speed - 600 RPM

Brass Gear Pump

Part Number	Description
113778	Brass Gear Pump



FOAM MARKERS

FEATURES:

- Visually mark the edge of your sprayed area through deposits of foam balls.
- Avoid double coverage or lack of coverage during fertilizer or chemical applications.
- Easy to install and operate.
- Mixing water with foaming concentrate liquid in a 1.5 to 3 percent solution creates the foam.
- Foam is environmentally friendly.
- Foam is generated at the end of the boom, which eliminates the foam from breaking down in the boom and the waiting period for the foam to travel to end of the boom.
- All kits include 12-volt compressor, solution tank, control box and necessary parts for installation.

Foam Markers								
Part Number	Applicator Sprayer	Boom Size	Tank Size	Refill Time (Approx.)		Output (Balls/min)		Foam Nozzles
				Max Rate	Min Rate	Max Rate	Min Rate	
FM-150	Ag Sprayer	Up to 100 ft.	15 gal	4 hrs	7.5 hrs	23	17	2 Horizontal Switching
FM-64	Ag Sprayer	Up to 65 ft.	6.4 gal	2 hrs	2.5 hrs	31	18	2 Vertical Switching
FM-40	Golf/Turf	Up to 40 ft.	4 gal	2 hrs	3 hrs	25	18	2 Horizontal Switching
FM-40-1	Golf/Turf		4 gal	2 hrs	3 hrs	25	18	2 Vertical Switching
FM-10	ATV Sprayer	Up to 12 ft.	1 gal	1 hrs	3 hrs	22	12	2 Vertical Switching
FM-10-WB	Walk behind spreaders		1 gal	1 hrs	3 hrs	22	12	1 Vertical



FM-150 INCLUDES:

Factory mounted compressor on the tank

118 ft. of liquid and air tubing

Air tube: $\frac{5}{16}$ " diameter

Liquid tube: $\frac{1}{4}$ " diameter

15 ft. of cable to connect the remote switch to the compressor

6 ft. of power cable to connect remote switch to power supply

Optional Kits:

- Foam nozzle extension used to generate small foam stripes
- 150 ft. of air and liquid tubing for booms larger than 100 ft.



FM-64 INCLUDES:

Compressor is mounted separately from the tank.

82 ft. of liquid and air tubing.

Air tube: $\frac{1}{4}$ " diameter.

Liquid tube: $\frac{1}{4}$ " diameter.

15 ft. of cable to connect the remote switch to the compressor.

6 ft. of power cable to connect remote switch to power supply.



FM-40 AND FM-40.1 GOLF/TURF FOAM MARKERS

FM-40 has 52 ft. of liquid and air tubing (for end of boom discharge)

FM-40-1 has 15 ft. of liquid and air tubing (for center discharge)

Air tube: $\frac{1}{4}$ " diameter

Liquid tube: $\frac{1}{4}$ " diameter

15 ft. of cable to connect the remote switch to the compressor

Optional Kit:

- Switch Box Kit: Allows foam to be discharged from both ends at the same time
- 6 ft. of power cable to connect remote switch to power supply



FM-10 ATV FOAM MARKER

2 x 10 ft. of liquid & air tubing

Air tube: ¼" diameter

Liquid tube: ¼" diameter

10 ft. of cable to connect the remote switch to the tank

6 ft. of power cable connecting remote switch to power supply



FM-10-WB

7 ft. of liquid & air tubing

Air tube: ¼" diameter

Liquid tube: ¼" diameter

Rechargeable battery and charger included (approximately 2 ½ hours per charge)





- » The John Blue 12-Volt Pump is the only 12-Volt pump on the market today totally protected against weather, dust and overspray – it’s weatherproof tested.
- » Two models are available with 4.8 GPM capacity.

12-VOLT PUMPS

- Weatherproof tested—the only 12-Volt Pump to be totally protected against weather, dust and overspray
- Four piston diaphragm for a smoother flow
- Available quick connect ports system means it’s faster to install, requires fewer parts and connections while reducing the number of potential leak points.
- Integral pressure switch is fully sealed
- Low current draw results in a longer battery life
- Maximum operating pressure – 45 PSI
- Automatic demand
- Chemical resistant construction suitable for most fertilizers and chemicals
- Santoprene® diaphragms and valves.
- Viton® seals
- Glass-filled polypropylene housing
- Strainer is made from polycarbonate, 316 stainless steel 50 mesh screen.
- 1-year warranty

12-VOLT BATCH CONTROLLER

Accurately meter fluid on any brand pump for farm, lawn, and co-op.

Versatile meter is ideal for low-volume transfer. Calibrate accurately every time from system A to System B. Set in liters or gallons. Includes a time-out feature if left on for an extended period.



- Flow Rate 2 - 55 GPM
- Max. Amperage Range of 30 Amps
- Default Duty Cycle of 100%
- Polypropylene and Viton® Construction

12-Volt Pumps and Accessories	
Part Number	Description
AP1816W	4.8 GPM, max amp draw 13 amps, weight 6.4 lbs., inlet/outlet ports 15 mm quick connect ports including clear sight glass strainer, 5 hose barb quick connect fittings, min wire size 12 AWG.
AP1819W	4.8 GPM, max amp draw 13 amps, weight 6.4 lbs., inlet/outlet ports ½" NPT male, min wire size 12 AWG.
AK1317W	Universal Microswitch kit
AK1322W	Universal pump head
AK1319W	Universal inlet strainer 90 degrees
AK1584W	Quick connect ½" barb
AK1592W	Quick connect ¾" barb elbow
AK765-109W	Front Cover, ½" NPT
AK765-91W	Front Cover, 15mm Quick Connect
12VBC-100	12 Volt Batch Controller, Viton® O-Rings, 1" NPT Male Threads, Flow Rate 2-55 GPM, Max. Amperage Range of 30 Amps



AKSC35-202

12-VOLT SPEED CONTROLLERS

- Rheostat manual speed controller for 12-volt pumps.
- Available in 15 and 35 amp models.
- Accurate and smooth control over a wide range of RPM's
- Smoother adjustment of pump flow/pressure, which results in reduced sensitivity at the top of the adjustment scale.
- 6" wiring pigtailed for power input and output for motor standard
- Robust sealed wiring connectors
- Reversed polarity protection
- Heavy-duty OEM style stainless steel pressure sensor for positive liquid control
- In-line automotive style fuse
- Optional stainless steel ammonia gauge can be mounted either outside of the cab or onto the control box with the provided bracket.
- Available easy-to-read digital display, no chemicals in the cab
- Standard run/hold on 35 amp units
- On/off control switch with power indicator lamp
- 1-year warranty

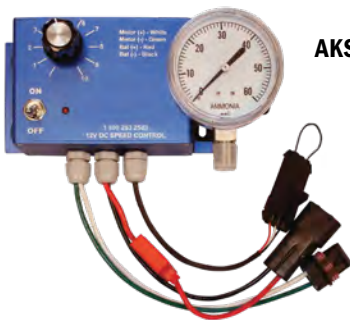

AKSC35-206

12-Volt Controller and Accessories

Part Number	Description
AKSC15-200	15 amp control, no gauge with wiring kit
AKSC15-201	15 amp control, with ss gauge, tube and wiring kit
AKSC15-205	15 amp control, no gauge or wiring kit
AKSC15-206	15 amp control with ss gauge only
AKSC35-200	35 amp control, no gauge with wiring kit
AKSC35-201	35 amp control, with ss gauge, tube and wiring kit
AKSC35-205	35 amp control, no gauge or wiring kit
AKSC35-206	35 amp control with ss gauge only
AKSC35-202	35 amp control digital gauge with wiring kit
AKSC35-207	35 amp control digital gauge, no wiring kit
AKSCP-023	60 PSI ss ammonia gauge kit - ¼" male npt inlet, includes: AKSCP-005 gauge, AKSCP-022 bracket, 90505 screws
AKSCP-029	Input/output cable set, includes: 10 ft. red/black power in, 20 ft. white/black motor out
AKSCP-030	Replacement digital pressure sensor assembly
AKSCP-031	20 ft. motor output extension cable
AKSCP-032	Replacement 20 ft. digital pressure sensor cable
AKSCP-033	Gauge, tube and fittings kit, includes: 20 ft. ¼" poly tube, union, ¼" npt male & female adapters, AKSCP-023 gauge kit
AKSCP-034	Mounting screw set, includes: 4 each #10-24x1" screws and ext. tooth washer locknuts



ACCESSORIES

MISCELLANEOUS

MISCELLANEOUS ACCESSORIES AND SERVICE KITS

John Blue offers a comprehensive range of pump accessories and service kits designed to simplify any job. Our products, from nuts and bolts to gasket kits, are all crafted with ease of use in mind. If you need expert assistance, the service professionals at our Huntsville, Alabama factory are always ready to help. For support, call 1-800-253-2583 and speak with a John Blue technician.

MISCELLANEOUS ACCESSORIES AND SERVICE KITS

Miscellaneous Drive Components83
 Seal & Gasket Repair Kits for Centrifugal Pumps83
 Seal Kits for Centrifugal Pumps83
 Repair Kits for Pumps and Fittings83-84
 Squeeze Pump Hoses and Miscellaneous Parts85
 Operator Kits85
 Conversion Kits86
 Sprockets for Pumps without Clutch86



MISCELLANEOUS

1

2

3

4

5

6

7

Part Number	Description
Miscellaneous Drive Components - (For Pump Drives see pages 19-20)	
LA-1341-HA	Hub Sprocket Adaptor - 4 Bolt
106190-01	Hub Sprocket Adaptor - 5 Bolt
A-1341-HA	Hub Sprocket Adaptor - 6 Bolt
A-1342-BP	50 Tooth Roller Chain Sprocket (50)
A-1342-AP	60 Tooth Roller Chain Sprocket (50)
A-1502-P	80 Tooth Roller Chain Sprocket (50)
114565-91	35 tooth split sprocket for 7/8" hex shaft, for piston and squeeze pumps.
114936-91	32 tooth split sprocket for 7/8" hex shaft, for piston and squeeze pumps.
Seal & Gasket Repair Kits for Centrifugal Pumps - (For Centrifugal Pumps see pages 39-45)	
103274	Seal & Gasket Repair Kit - 1 1/2" and 2" Straight Centrifugal, Double Seal Viton®
103276	Seal & Gasket Repair Kit - 2" Self-Priming Centrifugal Pump, Double Seal Viton®
103277	Seal & Gasket Repair Kit - 3" Straight Centrifugal, Double Seal Viton®
103278	Seal & Gasket Repair Kit - 3" Self-Priming Centrifugal, Double Seal Viton®
110128	Seal & Gasket Kit - S-3325 and S-3325-DS (Ceramic)
116248	Seal & Gasket Repair Kit - 2nd Generation, 3" Self-Priming Centrifugal Pump, Double Seal Viton®
116249	Seal & Gasket Repair Kit - 2nd Generation, 2" Self-Priming Centrifugal Pump, Double Seal Viton®
116403-91	PSP-3240 Seal and O-ring Kit
116525-91	PSP-3340 Seal and O-ring Kit
116773	Gasket Repair Kit - For SP-3345-P Pump
Seal Kits for Centrifugal Pumps - (For Centrifugal Pumps see pages 39-45)	
S-3756	Seal Kit - 1 1/2" and 2" Straight and Self-Priming Centrifugal, Double Seal Viton®
S-3757	Seal Kit - 3" Straight and Self-Priming Centrifugal, Double Seal Viton®
103839-91	Seal Kit - S-3680 and S-3681 Hydraulic Motor
110127	Seal Kit - S-3325, S-3325-DS and SP-3325 Truck Pump
110129	Seal Kit - S-3350 and S-3330-DS Truck Pump
116804-01	Seal Kit - CS-200-H
116777-01	Seal Kit - CS-155RG
116813-01	Seal Kit - CS-200-HA
116814-01	Seal Kit - CS-150-HA
Repair Kits for Pumps and Fittings - (Continued on next page)	
F-592	Gasket Repair Kit - For Acid Pumps FA-500 and FA-501
F-592-U	Gasket Repair Kit - For Fumigant Pumps FA-500-U, FA-500 and FAC-500-U
109414	Gasket Repair Kit - For Acid Pumps FA-550 and FA-551
109415	Gasket Repair Kit - For Fumigant Pumps FU-550 and FU-551
104120	Gasket Repair Kit - For A-1610 N-Serve Pump
113604	Gasket Repair Kit - For A-1610-A Pump
L-1095-B	Gasket Repair Kit - For L-1094 Pump (for SN Above 2100) and L-905 Pump
L-3090	Gasket Repair Kit - For L-3000-SS, L-4900, L-4905 and L-4910 Pumps

Part Number	Description
Repair Kits for Pumps and Fittings	
L-4090	Gasket Repair Kit - For L-4000-SS, L-4400, and L-4409 Pumps
L-4090-U	Gasket Repair Kit - For L-4400 Fumigant Pump
106029	Gasket Repair Kit - For L-5100 Pump
115036	Gasket Repair Kit - For LM-1255 Pump
113717	Gasket Repair Kit - For LM-2450 Pump
111953	Gasket Repair Kit - For LM-4450 and L-4400-HS Pumps
111947	Gasket Repair Kit - For LM-4950 and L-4900-HS Pumps
116134	Gasket Repair Kit - For NGP-4055-F
116135-DR	Gasket Repair Kit - For NGP-5055-DRF
115788	Gasket Repair Kit - For NGP-6050
115688	Gasket Repair Kit - For NGP-7050
115789	Gasket Repair Kit - For NGP-8050
115789-AR	Gasket Repair Kit - For NGP-8055-AR
115789-DR	Gasket Repair Kit - For NGP-8055-DR
116135-AR56	Gasket Repair Kit - For NGP-5655-ARF
115689	Gasket Repair Kit - For NGP-9050
116457	Gasket Repair Kit - For NGP-4055-HY
116458	Gasket Repair Kit - For NGP-6055-HY
116459	Gasket Repair Kit - For NGP-7055-HY
116460	Gasket Repair Kit - For NGP-9055-HY
115788-S	Gasket Repair Kit-For NGP-6050-S
115788-U	Gasket Repair Kit-For NGP-6050-U
115688-S	Gasket Repair Kit-For NGP-7050-S
115688-U	Gasket Repair Kit-For NGP-7050-U
115789-S	Gasket Repair Kit-For NGP-8055-S
115789-U	Gasket Repair Kit-For NGP-8055-U
115689-AR	Gasket Repair Kit-For NGP-9055-AR
115689-DR	Gasket Repair Kit-For NGP-9055-DR
115689-S	Gasket Repair Kit-For NGP-9050-S
115689-U	Gasket Repair Kit-For NGP-9050-U
113842	Fumigant Kit - For LM-2450 Pump
114638	Fumigant Kit - For LM-4450 and L-4400-HS Pumps
114899	Fumigant Kit - For LM-4950 and L-4900-HS Pumps
113016	Repair Kit - For L-4600 Pump
115041	Repair Kit - For Low Volume Irrigation Injection Unit
115404	Repair Kit - IN-1716-SA/SF, IN-1000-SA/SF
115283-91	Repair Kit - Pumping End Only - IN-1716-SA/SF, IN-1000-SA/SFO
106531	Repair Kit - For 105429 Hydraulic Control
116811-02	Seal Kit - For Gear Tek 107030-02/107030-03 Hyd. Motors

**Gasket Repair Kit includes all gaskets and rubber seals; o-rings, piston seals, rod seals and crankshaft seals*

Part Number	Description
-------------	-------------

Squeeze Pump Hoses and Miscellaneous Parts - (Squeeze Pumps are on pages 34-36)

L-1265	Squeeze Pump Hose Kit - 6 Hose Set, 1/2" Hose
LA-1265	Squeeze Pump Hose Kit - 8 Hose Set, 5/16" Hose
87249	Squeeze Pump Hose - 1 Hose, 1/2" Hose
87250	Squeeze Pump Hose - 1 Hose, 5/16" Hose
A-3127-G	Gasket for Fill Valve
08-0010	3/8" Diameter Squeeze Tube for "B" Model Pump
08-0020	5/8" Diameter Squeeze Tube for "L" Model Pump
08-0015	Inlet Fitting Stainless Steel "B" Pump
08-0013	Outlet Fitting Stainless Steel "L" Pump
08-0021	Inlet Fitting Stainless Steel "L" Pump
08-0022	Outlet Fitting Plastic "L" Pump

Operator Kits - (Includes Manuals and Slide Rules)

115390	Operators Kit - LM 1255 Piston Pump
115391	Operators Kit - LM 2450 Series Piston Pump
115392	Operators Kit - L-4400 Series Piston Pump
115393	Operators Kit - LM-4450 Series Piston Pump
115394	Operators Kit - LM-4950 Series Piston Pump
115280-91	Mounting Kit for LM and L Series Piston Pumps
115787	Operators Kit - NGP Series Piston Pump



Part Number	Description
Conversion Kits	
105429	Hydraulic Throwout Conversion Kit - For L-4400, LM-4450 and LM-4950 Series Pumps
113647	Hydraulic Throwout Conversion Kit - For LM-2450 Series Pumps
115670	Manual Clutch Add On - NGP Universal
115671	Hydraulic Clutch Add On - NGP Universal
115672	Electric Clutch Add On - NGP Universal
115406-A	Needle and Seal Kit -FD-0610, FD-1200 & FD-1210
115433-A	Needle and Seal Kit-FD-2000 & FD-2010
116063	FD-0610 Spring Adjustment Kit
116064	FD-1210 Spring Adjustment Kit
116065	FD-2010 Spring Adjustment Kit
116064-A	FD-1200 Spring Adjustment Kit - With Needle and Cap
116065-A	FD-2000 Spring Adjustment Kit - With Needle and Cap
Sprockets for Pumps without Clutch	
114516-01	12 Tooth Sprocket - RC 40, 1" Bore
113905-01	18 Tooth Sprocket - RC 40, 1" Bore
115156-01	18 Tooth Sprocket - RC 40, 7/8" Hex
114517-01	23 Tooth Sprocket - RC 40, 1" Bore
114932-01	32 Tooth Sprocket - RC 40, 1" Bore
114936-91	32 Tooth Sprocket - RC 40 Split for 7/8" Hex
114565-91	35 Tooth Sprocket - RC 40 Split for 7/8" Hex
113611-01	11 Tooth Sprocket - RC 50, 1" Bore
114677-01	14 Tooth Sprocket - RC 50, 1" Bore
113685-01	16 Tooth Sprocket - RC 50, 1" Bore
106532-01	18 Tooth Sprocket - RC 50, 1" Bore
115157-01	18 Tooth Sprocket - RC 50, 7/8" Hex
112773	24 Tooth Sprocket - RC 50, 1" Bore
112774	36 Tooth Sprocket - RC 50, 1" Bore
Pulsation Dampener	
116344-91	Pulsation Dampener for all John Blue Piston Pumps

INTERESTED IN A CUSTOM ORDER?

John Blue has a variety of customers from agriculture, landscape, to industrial. If you would like to discuss a custom order for your company, give us a call, 1-800-253-2583.





THE PUMP COMPANY
SINCE 1886

📍 165 Electronics Boulevard SW
Huntsville, AL 35824 USA

☎ Toll-Free: 1-800-253-2583

📠 Fax: 1-256-721-9091

@ info@johnblue.com

🌐 johnblue.com



2024-2025
VOLUME XXIII

PRODUCT CATALOG



AUTHORIZED DEALER NETWORK

Genuine pumps, parts, and service are distributed through an extensive authorized dealer network.

Visit the Dealer Locator on our website:

johnblue.com/dealers

©Copyright 2024 to John Blue Company. All rights reserved. Products and specifications are subject to change without notice. All other product and company names are trademarks™ or registered® trademarks of their respective holders. Use of them does not imply any affiliation with or endorsement by them.

